



Varazdin Development and Entrepreneurship Agency
in cooperation with
Odessa State Academy of Civil Engineering and Architecture
University North
Faculty of Management University of Warsaw
Faculty of Law, Economics and Social Sciences Sale - Mohammed V University in Rabat



Economic and Social Development

32nd International Scientific Conference on Economic and Social Development

Editors:

Anatolij V. Kovrov, Oleg A. Popov, Anita Ceh Casni

Book of Proceedings

ISSN 1849-7535

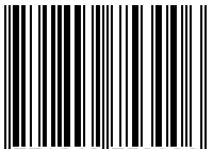

9 771849 753006 >

Odessa, 21-22 June 2018

Varazdin Development and Entrepreneurship Agency
in cooperation with
Odessa State Academy of Civil Engineering and Architecture
University North
Faculty of Management University of Warsaw
Faculty of Law, Economics and Social Sciences Sale - Mohammed V University in Rabat

Editors:
Anatolij V. Kovrov, Oleg A. Popov, Anita Ceh Casni

Economic and Social Development
32nd International Scientific Conference on Economic and Social Development

Book of Proceedings

Odessa, 21-22 June 2018

Title ■ Economic and Social Development (Book of Proceedings), 32nd International Scientific Conference on Economic and Social Development

Editors ■ Anatolij V. Kovrov, Oleg A. Popov, Anita Ceh Casni

Scientific Committee ■ Marijan Cingula, University of Zagreb, Croatia (President); Sandra Raquel Alves - University of Aveiro, Portugal; Ayuba A. Aminu, University of Maiduguri, Maiduguri, Nigeria; Anona Armstrong, Victoria University, Australia; Gouri Sankar Bandyopadhyay, The University of Burdwan, Rajbati Bardhaman, India; Haimanti Banerji, Indian Institute of Technology, Kharagpur, India; Elisabeth de Jesus Oliveira Brito - University of Aveiro, Portugal; Alla Bobyleva, The Lomonosov Moscow State University, Russia; Leonid K. Bobrov, State University of Economics and Management, Novosibirsk, Russia; Rado Bohinc, University of Ljubljana, Slovenia; Zeki Atil Bulut, Dokuz Eylul University, Turkey; Adnan Celik, Selcuk University - Konya, Turkey; Angelo Maia Cister, Federal University of Rio de Janeiro, Brazil; Mirela Cristea, University of Craiova, Romania; Sreten Cuzovic, University of Nis, Serbia; Oguz Demir, Istanbul Commerce University, Turkey; T.S. Devaraja, University of Mysore, India; Onur Dogan, Dokuz Eylul University, Turkey; Darko Dukic, University of Osijek, Croatia; Gordana Dukic, University of Osijek, Croatia; Alba Dumi, Vlora University, Vlore, Albania; Ksenija Dumcic, University of Zagreb, Croatia; Galina Pavlovna Gagarinskaya, Samara State University, Russia; Fran Galetic, Zagreb University, Croatia; Mirjana Gligoric, Faculty of Economics, Belgrade University, Serbia; Mehmet Emre Gorgulu, Afyon Kocatepe University, Turkey; Aleksandra Grobelna, Gdynia Maritime University, Poland; Liudmila Guzikova, Peter the Great Saint-Petersburg Polytechnic University, Russia; Anica Hunjet, University North, Koprivnica, Croatia; Oxana Ivanova, Ulyanovsk State University, Ulyanovsk, Russia; Irena Jankovic, Faculty of Economics, Belgrade University, Serbia; Lara Jelenc, University of Rijeka, Croatia; Myrl Jones, Radford University, USA; Gorazd Justinek, Graduate School of Government and European Studies, Slovenia; Hacer Simay Karaalp, Pamukkale University, Turkey; Grzegorz Karasiewicz, University of Warsaw, Poland; Dafna Kariv, The College of Management Academic Studies, Rishon Le Zion, Israel; Salih Katircioglu, Eastern Mediterranean University, Northern Cyprus, Turkey; Hilal Yildirim Keser, Uludag University, Bursa, Turkey; Martina Dragija Kostic, Sophia Khalimova, Institute of Economics and Industrial Engineering of Siberian Branch of Russian Academy of Science, Novosibirsk, Russia; Marina Klacmer Calopa, University of Zagreb, Croatia; Vladimir Kovsca, University of Zagreb, Croatia; Goran Kozina, University North, Koprivnica, Croatia; Dzenan Kulovic, University of Zenica, Bosnia and Herzegovina; Robert Lewis, Les Roches Gruyère University of Applied Sciences, Bulle, Switzerland; Ladislav Lukas, Univ. of West Bohemia, Faculty of Economics, Czech Republic; Pascal Marty, University of La Rochelle, France; Vaidotas Matutis, Vilnius University, Lithuania; Marjana Merkac Skok, GEA College of Entrepreneurship, Ljubljana, Slovenia; Daniel Francois Meyer, North West University, South Africa; Marin Milkovic, Rector, University North, Koprivnica, Croatia; Zlatko Nedelko, University of Maribor, Slovenia; Gratiela Georgiana Noja, West University of Timisoara, Romania; Zsuzsanna Novak, Corvinus University of Budapest, Hungary; Alojzy Z. Nowak, University of Warsaw, Poland; Mislav Ante Omazic, University of Zagreb, Croatia; Vera Palea, Università degli Studi di Torino, Italy; Dusko Pavlovic, Libertas International University, Zagreb, Croatia; Igor Pihir, University of Zagreb, Croatia; Dinko Primorac, University North, Koprivnica, Croatia; Zeljka Primorac, University of Split, Croatia; Mirosław Przygoda, University of Warsaw, Poland; Nicholas Recker, Metropolitan State University of Denver, USA; Kerry Redican, Virginia Tech, Blacksburg, USA; Humberto Ribeiro, University of Aveiro, Portugal; Robert Rybnicek, University of Graz, Austria; Elzbieta Szymanska, Bialystok University of Technology, Poland; Katarzyna Szymanska, The State Higher School of Vocational Education in Ciechanow, Poland; Jan Turyna, University of Warsaw, Poland; Ilaria Tutore, University of Naples Parthenope, Italy; Claudia Miranda Veloso - University of Aveiro, Portugal; Rebeka Danijela Vlahov, University of Zagreb; Ilko Vrankic, University of Zagreb, Croatia; Thomas Will, Agnes Scott College, USA; Li Yongqiang, Victoria University, Australia; Peter Zabielskis, University of Macau, China; Tao Zeng, Wilfrid Laurier University, Waterloo, Canada; Snezana Zivkovic, University of Nis, Serbia.

Review Committee Marina Klacmer Calopa (President); Ana Aleksic; Sandra Raquel Alves; Ayuba Aminu; Mihovil Andjelinovic; Josip Americ; Lidija Bagaric; Tomislav Bakovic; Sanja Blazevic; Leonid Bobrov; Ruzica Brecic; Anita Ceh Casni; Mirela Cristea; Oguz Demir; Jasmina Dvorski; Stjepan Dvorski; Robert Fabac; Ivica Filipovic; Sinisa Franjic; Fran Galetic; Mirjana Gligoric; Tomislav Globan; Anita Goltnik Urnaut; Tomislav Herceg; Irena Jankovic; Emina Jerkovic; Dafna Kariv; Oliver Kesar; Hilal Yildirim Keser; Tatjana Kovac; Vladimir Kovsca; Angelo Maia Cister; Katarina Marosevic; Vaidotas Matutis; Marjana Merkac Skok; Josip Mikulic; Ljubica Milanovic Glavan; Daniel Francois Meyer; Natanya Meyer; Guenter Mueller; Ivana Nacinovic Braje; Zlatko Nedelko; Gratiela Georgiana Noja; Zsuzsanna Novak; Alka Obadic; Claudia Ogorean; Igor Pihir; Najla Podrug; Vojko Potocan; Dinko Primorac; Zeljka Primorac; Sanda Renko; Humberto Ribeiro; Vlasta Roska; Souhaïla Said; Armando Javier Sanchez Diaz; Tomislav Sekur; Lorena Skufflic; Mirko Smoljic; Petar Soric; Mario Spremic; Matjaz Stor; Tomasz Studzieniecki; Lejla Tijanic; Daniel Tomic; Boris Tusek; Rebeka Daniela Vlahov; Ilko Vrankic; Thomas Will; Zoran Wittine; Tao Zeng; Snezana Zivkovic; Berislav Zmuk.

Organizing Committee ■ Domagoj Cingula (President); Marina Klacmer Calopa; Spomenko Kesina; Erlino Koscak; Mirosław Przygoda; Rebeka Danijela Vlahov.

Publishing Editor ■ Domagoj Cingula

Publisher ■ **Design** ■ **Print** ■ Varazdin Development and Entrepreneurship Agency, Varazdin, Croatia / Odessa State Academy of Civil Engineering and Architecture / Faculty of Management University of Warsaw, Warsaw, Poland / University North, Koprivnica, Croatia / Faculty of Law, Economics and Social Sciences Sale - Mohammed V University in Rabat, Morocco

Printing ■ Online Edition

ISSN 1849-7535

The Book is open access and double-blind peer reviewed.

Our past Books are indexed and abstracted by ProQuest, EconBIZ, CPCI (WoS) and EconLit databases and available for download in a PDF format from the Economic and Social Development Conference website: <http://www.esd-conference.com>

© 2018 Varazdin Development and Entrepreneurship Agency, Varazdin, Croatia; Odessa State Academy of Civil Engineering and Architecture, Odessa, Ukraine; Faculty of Management University of Warsaw, Warsaw, Poland; University North, Koprivnica, Croatia; Faculty of Law, Economics and Social Sciences Sale - Mohammed V University in Rabat, Morocco. All rights reserved. Authors are responsible for the linguistic and technical accuracy of their contributions. Authors keep their copyrights for further publishing.

CONTENTS

PARTICIPATORY BUDGETING AS A FORM OF COMMUNITY INVOLVEMENT IN THE TERRITORIAL GOVERNMENT BODIES MANAGEMENT.....	1
Agnieszka Smalec	
QUALITY DIMENSION IN THE CONTEXT OF CONSUMERS.....	11
Andzela Veselova	
METHODS OF CONSTRUCTION DURATION ESTIMATION	23
Irina Azarova	
DETERMINANTS AND METHODS OF IMPLEMENTING LOCAL GOVERNMENT TASKS.....	28
Beata Sadowska	
MBTI MODEL APPLICATION FOR THE ACMEOLOGICAL-INVARIANT ORGANIZATION MANAGEMENT AS AN INSTRUMENT FOR “BREAK-THROUGH” INNOVATIONS IMPLEMENTATION	35
Olena Shcherbak, Liudmyla Ganushchak–Efimenko, Nataliia Kulak	
SUSTAINABLE DEVELOPMENT OF MUNICIPALITIES AND SMART CITIES CONCEPT IN THE CZECH REPUBLIC.....	44
Veronika Humlerova, Petra Partlova	
FORMATION OF THE INVESTMENT POTENTIAL OF THE CONSTRUCTION SECTOR (ON THE EXAMPLE OF UKRAINE).....	51
Shlafman Natalya, Frolina Kateryna	
DEVELOPMENT OF BUSINESS EDUCATION IN UKRAINE.....	66
Viktoriia Kryvoruchko	
APPLICATION OF METHODS OF CATASTROPHE THEORY IN THE TECHNOLOGY OF CONSTRUCTION COMPOSITE MATERIALS.....	76
Larysa Trofimova	
WRITTEN COMMUNICATION OF A LARGE ORGANIZATION WITH INSTITUTIONAL CUSTOMERS	85
Grazyna Rosa, Izabela Ostrowska, Leszek Gracz, Kamila Slupinska	
IMPACT OF IMPLEMENTED CLOUD TECHNOLOGY ON THE STRUCTURE CENTRALIZATION AND FORMALIZATION IN MANUFACTURING COMPANIES – RESEARCH RESULTS	95
Magdalena Zalewska-Turzynska	
CAPITALIZATION RATE FOR LANDS IN LARGE CITIES OF UKRAINE: APPROACHES TO THE DEFINITION OF SPATIAL HETEROGENEITY	104
Andrii Martyn, Anatolii Kolosiuk	

A REVIEW OF MANAGEMENT OF INFRASTRUCTURE ROAD ASSETS	111
Vasiliy Mitinskiy, Olena Vashchynska, Nataliya Shyriaieva, Olha Khmaruk	
MANAGEMENT OF ECONOMIC PROCESSES OF CITY SPACE SYSTEMS.....	118
Olena Bileha	
FACTORS AFFECTING THE DEVELOPMENT OF TOURISM INDUSTRY	125
Olga Kambur, Nataliia Petryshchenko, Nataliia Serohina	
THEORETICAL FOUNDATIONS OF SUBURBAN ZONE BOUNDARIES DEFINITION.....	134
Oliinyk V. D.	
KALININGRAD REGION AS A TOURIST GENERATING AREA FOR THE BALTIC SEA REGION.....	139
Tomasz Studzieniecki, Marzena Wanagos, Ilona Urbanyi-Popiolek	
SYNTHESIS OF PEDAGOGICAL AND TECHNICAL EDUCATION: VECTORS OF DEVELOPMENT LEAN-EDUCATION.....	148
Svitlana Yermakova	
ENTREPRENURIAL BEHAVIOR CHANGING INFLUENCED BY MIGRATION PROCESSES.....	158
Hanna Bei, Larysa Sarkisian, Ganna Sereda	
CRISIS MANAGEMENT AND HOW TO EMPOWER IT WITH CROWDSOURCING	166
Goran Pavelin, Djani Bunja, Franjo Mlinac	
REVITALIZATION OF INDUSTRIAL ZONES OF THE BIG CITY (EVIDENCE FROM THE CITY ODESSA).....	174
Irina Pedko, Anastasiia Pandas	
SELECTING AN OPTIMAL STRUCTURE OF CO-BRANDING ALLIANCE FOR AN INTEGRATED BUSINESS STRUCTURE.....	181
Valeriia Shcherbak, Olena Nifatova, Olena Kaliuzhna	
FACTORS OF THE COUNTRY'S ENERGY SECURITY	191
Svetlana Rakytska, Oksana Zhus, Vladimir Mishchenko	
DEVELOPMENT OF TRADE RELATIONS BETWEEN CENTRAL EUROPE AND SCANDINAVIA AS A DETERMINANT CREATING POLISH FERRY SHIPPING MARKET	199
Ilona Urbanyi-Popiolek, Tomasz Studzieniecki	
CAN BITCOIN BE THE FUTURE OF DIGITAL PAYMENTS?	206
Andrea Valente, David Atkinson, John Clifford	
MATERIALITY IN ACCOUNTING AND AUDITING	218
Iwona Kumor, Ewa Mackowiak	

THE INFLUENCE OF PRODUCTION SUBCONTRACTING FORMS ON THE DEVELOPMENT OF SMALL BUSINESS FIRMS IN NIGERIA.....	226
Nwokocha Victor Chukwunweike	
GLOBALIZATION PROCESSES AND TRANSNATIONALIZATION OF THE ECONOMY.....	237
Olga Vyshnevskya, Olena Kaliuzhna, Irina Banyeva	
FEATURES OF PLANNING IT - PROJECT OF MODERNIZATION ACCESS SYSTEM OF SEA PORT.....	247
Viktoriiia Denysenko, Iryna Kornieieva, Dina Lazarieva	
MARKETING ASPECTS OF URBAN PLANNING AND AGGLOMERATION DEVELOPMENT.....	253
Volodymyr Levovich Glazyrin, Iosyp Volodymyrovych Shkrabyk, Mykola Pavlovych Sakhatskyi, Pavlo Mykolaiovych Sakhatskyi	
THE DEVELOPMENT OF THE TOURIST PRODUCT OF THE CITY AND THE INFORMATION NEEDS OF TOURISM ENTITIES.....	262
Marzena Wanagos, Tomasz Studzieniecki	
INTEGRATED EDUCATIONAL BRANDING AS SOURCE OF MARKETING COMMUNICATIONS OF HIGHER EDUCATIONAL INSTITUTION.....	269
Svitlana Yermakova	
MONITORING OF ARCHITECTURAL MONUMENT CONTINUES.....	279
Yurkovsky R.G., Nakhmurov O.N., Shishkalova N.Y., Zakharchuk V.V., Kolomiets N.P.	
DEVELOPMENT OF DEVICE TECHNOLOGY ANTI-FILTRATION SCREEN WITH USE SCREW EQUIPMENT.....	288
Alexander Meneyliuk, Anatoly Petrovsky, Alexander Borisov, Stanislav Kyryliuk	
ENERGY-SAVING AS A NECESSARY FACTOR OF THE MODERN DEVELOPMENT ON THE EXAMPLE UKRAINE.....	294
Kateryna Tiulkina	
GROSS AND NET ASSETS IN THE EUROPEAN UNION COMMUNITY IN 2006 - 2016 (CASE STUDIES).....	303
Urszula Banaszczak-Soroka	
SOURCES OF ECONOMIC GROWTH IN THE AFRICAN, CARIBBEAN AND PACIFIC COUNTRIES.....	313
Wioletta Nowak	
MODERN GOING FOR CORPORATE MANAGEMENT AND ITS FEATURE ENTERPRISES IN UKRAINE.....	325
Azhaman I. A., Klyuchnik A. V., Telichko N. A.	
RESEARCHING THE VIEWS OF STUDENTS AT THE UNIVERSITY NORTH....	333
Anica Hunjet, Goran Kozina, Damira Djukec	

FACEBOOK AS A PLATFORM IN PROMOTING CONTINENTAL TOURISM	345
Zeljka Zavisic, Senka Zavisic, Neven Sipic	
COST MANAGEMENT IN AIR TRANSPORT COMPANIES.....	354
Grzegorz Zimon	
COMPARATIVE ANALYSIS OF SELECTED AREAS OF MARITIME ECONOMY OF THE BALTIC SEA REGION COUNTRIES.....	361
Katarzyna Skrzyszewska	
A SMART CITY ASSESSMENT FRAMEWORK: THE CASE OF ISTANBUL'S SMART CITY PROJECT.....	369
Fatih Canitez, Muhammet Deveci	
PROSTITUTION IN THE REPUBLIC OF CROATIA	381
Dasa Panjakovic Senjic	
EXTENDING THE ROLE OF SERVQUAL MODEL IN ISLAMIC BANKS WITH SUBJECTIVE NORMS, CUSTOMER SATISFACTION AND CUSTOMER LOYALTY	387
Feras M.I. Alnaser, Mazuri Abd Ghani, Samar Rahi, Majeed Mansour, Hussein Abed, Ali Hawas Alharbi	

PARTICIPATORY BUDGETING AS A FORM OF COMMUNITY INVOLVEMENT IN THE TERRITORIAL GOVERNMENT BODIES MANAGEMENT

Agnieszka Smalec

*Faculty of Management and Economics of Services, University of Szczecin, Poland
agnieszka.smalec@wzieu.pl*

ABSTRACT

One of the assumptions of the democratic system of governing is the citizens' active participation in the management process. The citizens' participation is of a key significance to the effective management of the territorial government units. It builds up the sense of local community and co-responsibility for the decisions taken. The aim of the public participation is both the creation of an efficient system needed for the citizens' needs meeting and obtaining the citizens' acceptance of the actions by the authorities as well as the citizens' trust in the efficiency of the authority's activity. Such activities trigger the citizens' identification with the specific community and have them more likely to engage in its vital issues. The aim of this paper is to present the tools of social participation in the modern and integrated management of the units of territorial government; one particular instrument, i.e. the social (participatory) budget. This paper presents among others the idea of participatory budgeting and the phases of its creating. It also includes the comparison of data concerning participatory budgeting in selected cities/states. The author's intention is to contribute to the discussion on the citizens' participation and to start the study of its forms, such as the participatory budgeting. The method of documentary research has been applied, including the respective literature analysis as well as comparative analysis and observation.

Keywords: *citizens, management, participation, participatory budgeting, territorial government*

1. INTRODUCTION

Social participation makes part of modern management of public government units where the differences of interests and expectations must be negotiated and agreed rather than imposed in the form of administrative decisions. This gives an opportunity of gaining a greater social acceptance, increase in confidence and optimisation of decisions taken. The social involvement allows the citizens to participate in the process of public affairs management. The market economy development, the change of the citizens' role from an applicant to stakeholder or globalisation processes have the citizens get involved in the decision taking concerning the operations of their local government unit. This sees the local governments turn from administering to a new management form, creating convenient conditions for the cooperation between various stakeholders for the communities are becoming more and more demanding towards the quality of the decisions taken by the local administration. This paper focuses on one of the major instruments of the social participation, i.e. the participatory budgeting. The first part of the paper gives its brief characteristics while the second – on the basis of observation, comparative analysis and case studies – empirical results, thus supplementing the theoretic considerations concerning the secondary studies results and territorial administration experience.

2. THE ESSENCE AND IMPORTANCE OF SOCIAL PARTICIPATION

The issue of identifying the customers' needs in the European Union states often is given a priority thus coming to the top of the public administration sessions agenda (EIPA, 2007, p. 39). The European Union introduces many mechanisms which directly or indirectly affect the

local governments encouraging them to share the management. Recent years have seen an active supplementing of the traditional three-part dialogue with the participation of trade unions, employers and public authorities with the citizens' dialogue, which means the non-government organisations and single individuals. The activities undertaken by the state are focused on the effectiveness improvement, are based on the greater awareness of rendering services and emphasising the role and importance of the citizens. The management of the customers' satisfaction is becoming indispensable for public institutions in order for them to see if they do the right things and in the right way (more: *Zarządzanie...*, 2008). It is well justified due to the good governance system applied by the local authorities. This concept is based on the assumption that administration is a form of cooperation of various entities for the purpose of solving social problems. What counts here is participation, consensus, equality and contribution. Every citizen becomes a member fully entitled to take part in public decisions. It must be emphasized here that the civil society is not equal to civic society, i.e. a community of individuals enjoying citizens' rights and duties (Bokajło, 2001, p. 36). Those rights sparkle the need in the citizens to form civil societies but the constructive feature of that need is the "citizens' collective self-awareness" which decides about the sense of participation within the society and taking interest in the common aims and benefits (Słodkowska, 2006, p. 71). Authorities' duty is to rationally meet the individual and common needs in terms of spiritual and material development of the territorial community. It must not be forgotten that the local community's needs are subject to change therefore they should be monitored on a systematic basis. Contacting the local community should be one of major activities of the authorities while the utilities should form a specific value for the citizen (customer). For social problems must not be solved exclusively by the local administration; a cooperation with other entities, primarily local community, is required. To say it in the simplest way – the social participation is the active citizens' to the management of issues concerning the community life. It is a social process as a result of which the community consciously get involved in the issues that matter to them, share their experience and views and also get the opportunity to influence and control to some extent the decisions taken by the public authorities which have impact on their (the citizens') interests (Długosz, Wygnański, 2005, p. 11). The classic concept of public participation by Stuart Langton distinguishes four categories of citizens' cooperation in the lives of political communities (Langton, 1978; Kazimierczak, 2011, p. 85): the public activity, the citizens' involvement, electoral participation and obligatory participation understood as support offered to the administration through tax payment and citizens' taking part in court cases. In a broader meaning, it is a foundation for the civil society whose members voluntarily and actively participate in the activities. It is strictly linked to the social communication (dialogue) and the cooperation of the citizens with the authorities. Over recent years, in many countries a tendency has been observed to implement the concept of social participation as an element of actual local self-government and a tool for an effective management of the public wherewithal. Getting the citizens involved in the process (more precisely planning and direct decision taking) of the self-government unit funds heads for the implementation of the concept according to which the citizens directly or through their representatives in the councils decide about the use of the resources at the self-government units' disposal. Currently, the role of the public administration has ceased to be a traditional, domineering model of ruling for the benefit of power achieved by means of communication, discussion and understanding other entities (Sotarauta, 1996, p. 91). Marketing activities (even though they are only one of the elements of the territorial management) play a particular role in the development of these relations (Wanagos, 2010, p. 109–118). One of the key factors responsible for the success in public tasks implementation by the public sector is the confidence the citizens have in the authority. The activities undertaken by the local authorities must not be for their own sake but for the benefit of their recipients.

One of the major factors having impact on the social participation level is the application by the self-government some principles of institutional nature to encourage the citizens to get involved in the public issues management. The extent of the citizens' contribution is often dependent on their individual properties and the community attributes – the social capital. Participation is the democracy's necessary condition and the basis for civil society (Frost, 2003, p. 87–104). In order to have such society developed, the states must be based on very well shaped, stable structures of democracy enabling the openness and involvement of their citizens. Having the sense of their opinions heard, they are more likely to engage in local activities. The citizens' conviction of the importance of their participation in the public life and the local authorities' structures to come up with various solutions enabling such activities should primarily result from their awareness of the mutual benefits. The citizens get access to the common goods, may express their needs and meet them in a better way by a greater influence on the public decisions, they have a better control over the public institutions' operations or getting better understanding of the administration as such and thus learn the dialogue with the authorities representatives and other citizens. The social participation gives the citizens the sense of perpetration, an actual influence on the public policies, which motivates them for a more advanced activity in the public life thus consolidating the bonds between the authority and citizens or citizens with citizens (Schimanek, 2015, p. 8). The local self-government authorities reinforce the civil society in the first place, educate and integrate the citizens, reinforce the citizens' identification with the community, build up the confidence in the authorities, get more comprehensive knowledge on the needs of their community or just improve the efficiency or quality of the decisions taken. Therefore, a statement can be made that both parties benefit from the social participation model. It also is an important factor for the improvement of the local authorities management. Opting for the implementation of advanced social participation, the local authorities should be convinced about the benefits as this only gives the chance for achieving them. One must not forget, too, that it generates some expenses, such as additional time needed for decision taking, the skill to handle extreme opinions which can be levelled. It is very important that the participation of all the parties to the dialogue be held on the same principles and based on the conviction that the aim is to achieve the common goods and mutual benefits. S.R. Arnstein presented the social participation in the form of a ladder (Fig. 1): from a passive to an active participation in the debate and taking public decisions (more: Sherry, 2011).

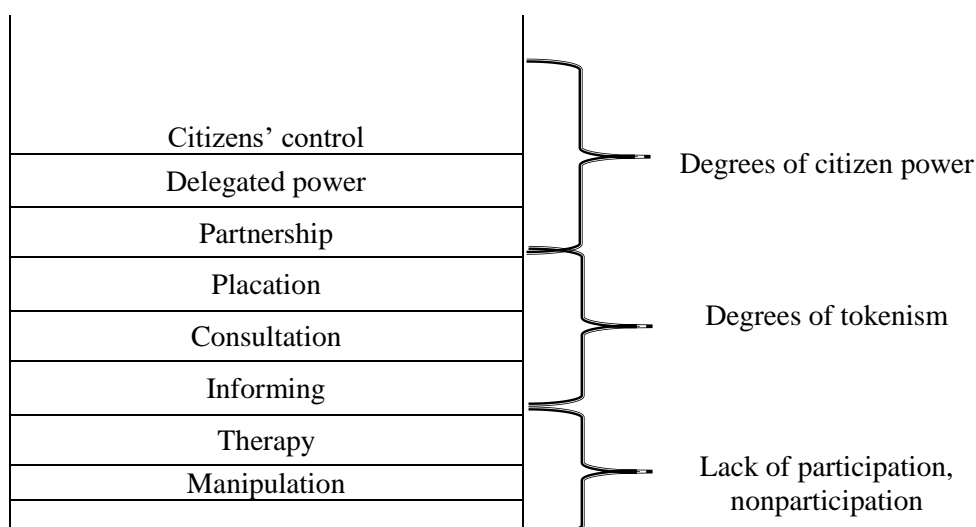

Figure 1. Participation Ladder (Arnstein, 1969, p. 217)

The citizens' public activity basic forms are the participation in elections and referendums, taking part in social consultations and meetings of the inhabitants with the local authorities, petitions writing, building up groups of support up to the most demanding forms such as activities in the non-governmental organisations sector. The citizens, according to mentioned concept by Langton, may also get involved in the decision-taking process with the local authorities. Such cooperation results mainly from the process facilitation and providing the most optimal and economically effective solutions from the point of the customer, which is the community for the benefit of which the local authorities undertake the activities. International Association for Public Participation specifies five levels of the citizens' involvement:

- a) informing – providing knowledge to the citizens, information about a specific problem, but also suggestions for solving it;
- b) consulting – organising the process of dual direction communication along the authority-citizen and citizen-authority line as well as the readiness to apply specific solutions and accepting comments;
- c) incorporation – inclusion of comments, opinions, solutions or their elements in the created, implemented or monitored public policies;
- d) cooperation – partnership at every stage of the decision-taking process;
- e) empowerment – transferring the final decision in the hands of the citizens.

Majority of local self-governments include the social partners only in the cases they are obliged by law to do so. The authorities usually confine their cooperation to submitting information to the citizens or social partners, possibly consulting the documents which are subject to consultation. One of the most popular instrument of social participation in Poland (and not only) aiming at engaging the citizens in the process of commune/city management, their funds in the first place, is the participatory budget.

3. PARTICIPATORY BUDGETING AS A FORM OF SOCIAL PARTICIPATION

Participatory budgeting (PB) was introduced for the first time in 1988 in the Brazilian city of Porto Alegre (capital of the Rio Grande do Sul region) (Santos, 1998, p. 405–510; Participatory..., 2018). It was a social initiative getting much support from the local authorities. The City Council passed a resolution on the procedure of the inhabitants co-deciding about the municipal expenses. The PB brought very noticeable results: well operating structures of the self-government, development of the poorest parts of the city, improvement of the democratic standards (Kębłowski, 2013, p. 12). By 2008 about 200 Brazilian cities had introduced it and subsequently it spread across South America (at least 510 cities engaged in the PB in 2010), in Europe (200 cities), in Africa, Asia and North America thus covering all the world – at least 795 cities can be spotted globally where it has been implemented; some surveys mention as many as over 1500 such cases (more: Gamuza, Baiocchi, 2012; Sintomer, Herzberg, Roecke, Allegretti, 2012). The participatory budget in Porto Alegre was based on two keystones – the involvement of the citizens and friendly approach of the city authorities; while three main principles of operation were assumed: grassroots democracy expressed by the meetings of the citizens from 16 districts, the principle of social justice implemented by means of allocation of resources and social control through the social budget council (Ostaszewski, 2013, p. 120). The World Bank interprets the participatory (citizen) budgeting as a process in the result of which the citizens present their demands and priorities and influence the structure of budget expenses through discussion and negotiation (see: Goldfrank, 2012). On his part B. Wampler – a researcher of the participation budgeting – states that it is a process of decision making owing to which the citizens discuss and negotiate the distribution of public resources (Wampler, 2007, p. 21). What is important here it is the clarity and democratic approach to decision making at open door.

The PB success in the Brazilian city was the result not only of right attitude of the local authority but the well developed forms of citizen participation as well. Such a budget creates an actual possibility for a direct contribution of the citizens to the decision making as to the public means management and allows them to discuss the budget suggestions thus involving them in all the stages of budget procedure. PB gives ordinary people real power over real money. The results of the participatory budget getting are binding, the citizens have a guarantee their will be honoured and the investment offers they have selected will be funded over the following budget year. It may be used on all administration levels. There exists no uniform model of resolving the SB by the local authorities. In the UK there appears the greatest variety of that budget models. Some of them are of general nature, others refer to particular elements of the local policies or individual projects (Łapińska 2012, p. 11). In the participatory budgeting researchers' opinion the introduction of its mechanism by local authorities causes the possible increase of chance for the mayor to be re-elected (Górski 2007, p. 70; Rytel-Warzocha 2010, p. 93 & subs.). Thus, it is obviously of great benefit for the local authorities while this mechanism favours the legitimization of the authorities. A great improvement in the communication with the citizens occurs which translates into an improved level of citizens' confidence in the local authorities. The PB procedure must be repeated (the repetition principle), must come in the form of public debates during special meetings or forums (the discussion principle) for the interested individuals to be able to speak out. It is also of major importance to control and settle the performance of the ideas undertaken within the PB. Information and education campaign is very important so that every inhabitant can take part in the work on the PB. The most complete PB form is when a specific amount of money can be isolated from the local administration budget to be fully taken care of by the inhabitants to cover the investment selected by them. There are some specific stages of work on the PB although the final shape may depend on many factors. The first thing is to make a decision on activating the PB process (the project preparation phase) and if so, the principles of its pattern must be set out. Then the permanent information-education campaign must be programmed. The next stage is the designing and proposing the projects which later are subject to discussion. Verification of the submitted projects and the threshold of their acceptance (usability, priority) should limit the authority activity to minimum (formal, technical and legal control) while the subject matter assessment should be given to the citizens. Following the discussion over the project there comes the general voting and the selection of the projects for implementation. Within the PB process it is very important to monitor the advancement of the project development and evaluation of the process. Within the participatory budgeting, the participants are able to gain skills and knowledge of city/commune management so that they become co-responsible for their place. The distribution of the funds must be done according to the so called priority inversion, which means allotting respectively larger amounts to most needing social groups and city areas. It has been emphasized in a British publication that "a well-organised participatory budgeting reinforces the communities, has the people keenly engage in the democracy and has a positive impact on the quality of the local public services" (Participatory budgeting..., 2009, p. 4). As it seems, the PB best proves right in the decision making concerning the territorial policy, because the inhabitants not only set up the investment priorities and the activities to be started but, what is more important, together create the concept of common good for their commune. At the most basic level, it need political will from above and community support from below. It need community organizations, in particular those working with marginalized communities, to engage people and push the process forward (What is PB..., 2018).

4. PARTICIPATORY BUDGETING IN THE PRACTICAL ISSUES OF TERRITORIAL SELF-GOVERNMENT MANAGEMENT

Using the observation, comparative analysis and case studies, selected participatory budgets have been presented thus completing the theoretical considerations. This paper is of a descriptive and explanatory nature. It is worth mentioning that in various countries or cities many different models of the participatory budgeting may be used yet everywhere the dialogue of different groups is the most vital component. The classical model of that Porto Alegre budget makes a good example of representative democracy, which was emphasized by the mayor of the city, Mr. Olivio Dutry who said that “if everybody took part in it, it would be like selling illusion of the ‘direct democracy’ in a Greek square which was not everybody’s democracy; it was the democracy of the best” (Sánchez-Pages, Aragonès, 2004, s. 2). The Polish start of the participatory budgeting took place in 2011 in Sopot. The analysis of the social budgets in four selected cities of Poland in 2017 showed that the amounts contributing to it grow from year to year. Most often, 20% to 30% of the said amounts go for general urban projects while 70% to 80% for the district improvements. The projects accepted for implementation in Polish cities over the recent years have been injected into the following types of projects:

- sports and leisure i.e. sportsgrounds, leisure facilities (such as parks, barbeque sites, rest areas), playgrounds, fitness studios, sports facilities,
- relating to road infrastructure: new roads, car parks, cycling paths, road mirrors, safe zebra crossings,
- medical and life-saving solutions facilitating the access to emergency medical units, purchase of tools for the fire brigade and purchase of life-saving medication,
- referring to culture, i.e. books purchase, authors’ lectures, monument erection, festive days celebration,
- referring to animals: animal shelters upgrade or animal help stations.

Among the analysed cities Lublin proved to be the leader (Fig. 2a) in terms of amounts of money which contributed to the PB per 1 citizen (in PLN) with the result of PLN 44, while in Bydgoszcz it was as little as PLN 15,8. It is obvious that deciding about a greater amount of money increases the sense of being perpetrators in the citizens and makes an incentive participate in the SB. Just to give some examples: the turnout in Lublin was 25%, in Gdańsk – 10%, and in Szczecin 9%. Where electronic voting is introduced, there is a rise in interest among young people between 15 and 16 years of age.

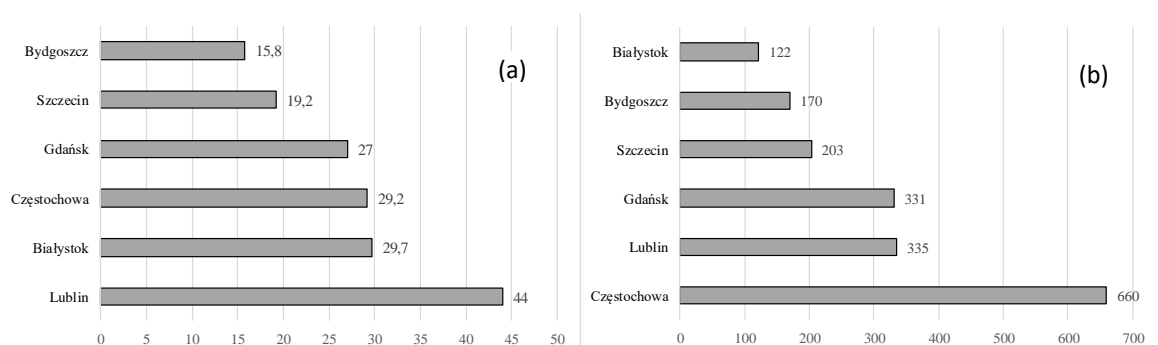

Figure 2. The amount allocated to the PB per 1 citizen (in PLN) (a) and the number of applications (b) in 2017 in selected cities (own elaboration)

The 660 projects entered in Częstochowa was a surprise as compared to the least number of projects entered in Białystok – 122 (Fig. 2b). Sadly, a fairly large percentage of projects in the cities under study did not pass the verification stage: from about 49% in Białymstok to 15% in

Lublin. Therefore, the discussion stage prior to the application submitting is of great importance to make it possible for the citizens to diagnose the needs or together with interested parties shape up the project. The German city of Cologne is the best example of how the citizens are furnished with the reliable information on the financial condition of the city to effectively bring it to the inhabitants (Buergerhaushalt, 2018). The social budget makes the financial foundation of the city of Cologne. The social budget organisers do their best to turn the specialist and expert knowledge to the form and language comprehensible for everyone. Many different communication channels are used. During the 2017 participatory budget preparation, much emphasis was given to the Internet dialogue. As a result, many applications referred to the whole city, not one district only. Many applications were about the budget expenses and suggestions to shift the expenses and income. It must be added that in the case of expenses most of the suggestions concerned education and natural environment. The City Council of Cologne indicated three main aims of this process: making the inhabitants better understand the city budget and thus obtaining a better sense of perpetration; encouraging people to take part in the process and supporting the dialogue between the citizens, politicians and city authorities as well as making it possible for the political parties to improve the effectiveness of their law-making activities through acting in the participation process. The city of Cologne based their participation budgeting programme on the “Beteiligungsverfahren” programme, i.e. “involvement” composed of four main stages: the open-access information, the dialogue and decision phase and the responsibility taking phase which provides insight into the decision results on a longer scale. In some cities, such as Eastfield in the UK, the social budget method was applied for the distribution of the relatively small resources (about 34 thousand GBP coming from the Safer Communities Partnership and Scarborough Borough Council in the North Yorkshire Police Authority programme) (Budżet..., 2015) for a specific reason, i.e. to select the projects which would contribute to reduce the local criminal records. The biggest success was the initiation of cooperation and the distrust barrier broken between the citizens and the inspectors and social workers. The projects selected by the citizens and completed also had an impact on reducing the criminal acts in the territory of the given community. Government administration allowed local government administration to cooperate at international level (Studzeniecki, Soares, 2017, p. 137). An example of countries cooperating for the aim of mutual benefits is the project by the PAUCI – the Polish-Ukrainian Cooperation Foundation “The participatory budgeting as a chance for expanding the citizens’ activity and a real partnership with the public authority” which aims at supporting the process of disseminating the growth of the inhabitants’ involvement in the decision taking processes in their cities and thus increasing level of the dialogue between the local authorities and local communities using the respective Polish experience. Apart from interregional, the transborder cooperation became one of the three linchpins for the territorial cooperation (Studzeniecki, Palmowski, Korneevets, 2016, p. 546; Morata, Noferini 2013, p. 174; Schutze 2015, p. 851). In March 2015, at the time of PAUCI experts meetings with the representatives of the local authorities and social leaders in Czerkasy, Połtawa and Czernichów, the issue of introducing the social budget mechanism in Ukraine was discussed (Budżet obywatelski: innowacyjny..., 2015). Mutual cooperation leads to a better economic situation increasing the competitiveness in regions and reduces the regional disparities in relations to other regions (Gajdova, Tuleja, 2015, p. 96). One of the first cities in Ukraine which were successful in implementing the participatory budgeting is the city of Czerkasy. More and more successful Ukrainian cities can be noticed. For example: in the city of Żytomierz the inhabitants could submit the project initiatives to participate in the social budget (UAH 9 mln.) from 12th July to 5th September 2016. a total of 67 applications were submitted worth total nearly UAH 41 million. In Sumy, for an instance, the inhabitants submitted 75 project applications to the social budget worth UAH 5 million.

In the city of Romny, on 21st August 2016, a vote was closed for 15 project initiatives brought by the citizens for the funding out of the city budget in 2016 (UAH 250 000). In the voting 425 persons took part (Budżet obywatelski – postępy..., 2016). The city of Sambor followed the model of Czerkasy which on 11.07. 2016 applied the first such budget contributing to it with UAH 200000,00 out of the 2017 budget (Samborski..., 2016). By 15th September 2016, the inhabitants of Sambor were given the opportunity of submitting the suggestions for the projects concerning the improvement of the life quality within the following areas: pavement improvement, street lighting, roads, improved appearance of the city, location of other leisure areas (Sambirian..., 2018). Before that time, the Sambor Agency for Development and Eurointegration (project partner) along with the city authorities organised meetings with the citizens to help them with the application preparing. The first voting for projects within the social budget in the history of Sambor was the final stage of the project completion where the citizens decided on what the money making part of the common city budget would be spent. Thus the first stage of the SB in Sambor is the information and education campaign followed by the project development and finally their presentation to the city communities and voting.

5. CONCLUSION

The important issues of the use of the participation budget in territorial administration management are the application of the right principles, such as transparency, project openness and inclusiveness, binding results, provision of area for debates with the participation of interested groups (mainly the citizens) or a long-term thinking process. The participation management is not a single gesture on the part of the city authorities but a permanent dialogue process occurring systematically between the clerks and inhabitants. Thus the information and education campaign for the citizens is very important so that every inhabitant could take part in the SB process at every stage. It is advisable to create the opportunities for citizen cooperation. Politicians in many countries seem to be better understanding that the citizens are real partners able to influence the surrounding, ready to work hard and keen on working for the benefit of their community. However, it is of major importance to stick to the due diligence with the procedures and honesty in mutual decision making so that politics would not turn into the battlefield of the antagonist political groups but make platform for the cooperation. The possibility of introducing the participatory budgeting as an influence tool of the citizens requires the obligation for several factors to appear jointly. Support from the executory bodies is of vital importance, who would be ready to delegate some of their competence for the sake of the citizens, as well as from the constituting bodies which, in turn, must accept that process. Citizens' society is also required who will have the opportunity to actively participate in all this process. There is also the need to have sufficient funds for the investments selected by the citizens. The voting of the projects must take a few days in order to facilitate the citizens vote in a traditional way, per mail or electronically. The process of projects selection should close at such moment, the city authorities would be able to incorporate them in the city budget for the following year. The participatory budget may prove a well-considered and executed reform (a system one as well), may be just a project, may also make a tool (which occurs in the citizens' budgets in Poland). It enhances citizens' integration and activation, opinion exchange, fulfills education aims and adds to the creation of the right citizens' attitudes. Owing to the participatory budgeting implementation, many various investments are possible which are likely to improve the citizens' lives. The examples of the cities using this form of participating democracy show that this practice results in a more equal distribution of public resources, higher quality of life, increased satisfaction from public services, better transparency and reliability of the public authorities, fuller participation in public life (specifically the excluded individuals) and social education. The participatory budgeting brings many advantages.

Yet, it must be emphasised the procedure of the social budget is work consuming and complex, it involves not only the citizens but also a greater number of clerks, therefore a specific period of time and engagement are needed to complete the process.

LITERATURE:

1. Arnstein S.R. (1969). A Ladder Of Citizen Participation, *Journal of the American Planning Association*, vol. 35, no. 4, p.216–224.
2. Bokajło, W. (2001). Społeczeństwo obywatelskie: sfera publiczna jako problem teorii demokracji. In W. Bokajło, K. Dziubka (eds.), *Społeczeństwo obywatelskie* (p. 36). Wrocław: Wydawnictwo Uniwersytetu Wrocławskiego.
3. *Budżet obywatelski – postępy ukraińskich miast* (6.09.2016). Retrieved 20.04.2018 from <http://pl.pauci.org/news/64>.
4. *Budżet obywatelski: innowacyjny proces włączania obywateli w formowanie polityki finansowej miast* (7.03.2015). Retrieved 20.04.2018 from <http://pl.pauci.org/news/1>
5. *Budżet partycypacyjny w Eastfield (Wielka Brytania)* (2015). Retrieved 20.04.2018 from <http://partycypacjaobywatelska.pl/strefa-wiedzy/przyklady-dzialan/budzet-lokalny/budzet-partycypacyjny-w-eastfield-wielka-brytania/>.
6. *Buergerhaushalt* (2018). Retrieved 20.04.2018 from <http://www.stadt-koeln.de/politik-und-verwaltung/mitwirkung/buergerhaushalt/>.
7. Długosz, D., Wygnański, J.J. (2005). *Obywatele współdecydują. Przewodnik po partycypacji społecznej*. Warszawa: Stowarzyszenie na rzecz Forum Inicjatyw Pozarządowych.
8. EIPA (2007). *Report on customer insight questionnaire*. Prepared on behalf of the Portuguese Presidency for the IPSG meeting 15–16, November, Lisbona.
9. Frost, A. (2003). Restoring faith in government: Transparency reform in the United States and the European Union. *European Public Law*, vol. 9 (1).
10. Gajdova, K., Tuleja, P., (2015). Cesko polske prihranicni regiony z hlediska sektoroveho zarazeni podniku. XVIII.mezinarodni kolokvium o regionalnich vedach. Sbornik prispevku. Brno: Masarykova univerzita.
11. Ganuza, E., Baiocchi, G. (2012). The Power of Ambiguity: How Participatory Budgeting Travels the Globe. *Journal of Public Deliberation*, vol. 8, iss. 2, article 8.
12. Goldfrank, B. (2012). The World Bank and the Globalization of Participatory Budgeting. *Journal of Public Deliberation*, vol. 8, iss. 2, article 7.
13. Górski, R. (2007). *Bez państwa. Demokracja uczestnicząca w działaniu*. Kraków: Korporacja Ha!art.
14. Kazimierzczak, T. (2011). Partycypacja publiczna: pojęcie, ramy teoretyczne. In A. Olech (ed.), *Partycypacja publiczna. O uczestnictwie obywateli w życiu wspólnoty lokalnej* (p. 83–99). Warszawa: Instytut Spraw Publicznych.
15. Kęłowski, W. (2013). *Budżet partycypacyjny. Krótka instrukcja obsługi*. Warszawa: Instytut Obywatelski.
16. Langton, S. (ed.). (1978). *Citizen Participation in America*. Lexington: Lexington Books.
17. Łapińska, H. (2012). Budżet partycypacyjny instrumentem zarządzania środkami publicznymi. Zeszyty Naukowe Wyższej Szkoły Finansów i Prawa w Bielsku-Białej, vol. 4, no. 4, p. 7–27.
18. Morata, F., Noferini, A. (2013). The Pyrenees – Mediterranean Euroregion Functional Networks actor perceptions and expectations. In: N. Bellini, U. Hilpert, (eds.), *Europe's Changing Geography: The Impact of Inter-regional Networks*. New York: Routledge.
19. Ostaszewski, K. (2013). *Partycypacja społeczna w procesie podejmowania rozstrzygnięć w administracji publicznej*. Lublin: Wydawnictwo KUL.

20. *Participatory Budgeting in Brazil* (2018). Retrieved 20.02.2018 from https://siteresources.worldbank.org/INTEMPowerment/Resources/14657_Participatory-Budgeting-Brazil-web.pdf
21. *Participatory budgeting values, principles and standards* (2009). Great Britain: The Participatory Budgeting Unit.
22. Rytel-Warzocho, A. (2010). Partycypacja społeczna w sprawach budżetowych. Model Porto Alegre jako pierwowzór rozwiązań europejskich. In W. Skrzydło (ed.), *Przegląd prawa konstytucyjnego*. Toruń: Wydawnictwo Adam Marszałek.
23. Sambirian Budget Of Public Initiatives [Самбірський Бюджет Громадських Ініціатив] (2018). Retrieved 20.04.2018 from <https://sambircity.gov.ua/gromadskij-byudzheth/>.
24. Samborski budżet obywatelski 2017 (2016). Retrieved 20.04.2018 from <http://www.horyzonty.man.rzeszow.pl/181-samborski-budzet-obywatelski-2017>
25. Sánchez-Pages, S., Aragonès, E. (2004). *A Model of Participatory Democracy: Understanding the Case of Porto Alegre*. Edinburgh: Edinburgh School of Economics, University of Edinburgh.
26. Santos, B. de S. (1998). Participatory budgeting in Porto Alegre: Toward a redistributive democracy. *Politics & Society*, vol. 26, no. 4, p. 461–510.
27. Schimanek, T. (2015). *Partycypacja obywatelska w społeczności lokalnej*. Warszawa: FISE.
28. Schutze, R. (2015). *European Union Law*. Cambridge: Cambridge University Press.
29. Sherry R. Arnstein – drabina społecznej partycypacji 1969. (2011). Retrieved 10.01.2018 from <http://teoriaarchitektury.blogspot.com/2011/02/sherry-r-arnstein-drabina-spoecznej.html>.
30. Sintomer, Y., Herzberg, C., Roecke, A., Allegretti G. (2012). Transnational Models of Citizen Participation: The Case of Participatory Budgeting. *Journal of Public Deliberation*, vol. 8, iss. 2, article 9.
31. Słodkowska, I. (2006). *Spółczesność obywatelska na tle historycznego przełomu. Polska 1980–1989*. Warszawa: Instytut Studiów Politycznych PAN.
32. Sotarauta, M. (1996). Formułowanie strategii zarządzania gminą w procesie harmonijnego rozwiązywania problemów. *Samorząd Terytorialny*, no. 1–2, 1996, p. 91.
33. Studzieniecki, T., Palmowski, T., Korneevets, V. (2016). The System of Cross-border Tourism in the Polish-Russian Borderland. *Procedia Economics and Finance*, vol. 39, p. 545–552.
34. Studzieniecki, T., Soares, J.R.R. (2017). Interregional Tourism Cooperation: A Europe Case Study. *Holos*, vol. 33, iss. 4, p. 135–158.
35. Wampler, B. (2007). A Guide to participatory budgeting. In A. Shah (ed.), *Participatory Budgeting*. Washington: The World Bank.
36. Wanagos, M. (2010). Rola działań marketingowych samorządów lokalnych w rozwoju turystyki na przykładzie województwa pomorskiego. *Prace Naukowe Uniwersytetu Ekonomicznego we Wrocławiu*, no. 109, p. 109–118.
37. *What is PB* (2018). Participatory Budgeting Project Retrieved 20.04.2018 from <https://www.participatorybudgeting.org/what-is-pb/>.
38. *Zarządzanie satysfakcją klienta. Europejski poradnik praktyka*. (2008). Warszawa: KPRM.

QUALITY DIMENSION IN THE CONTEXT OF CONSUMERS

Andzela Veselova

University of Latvia, Aspazijas blvd 5, Latvia LV 1050

andzela.veselova@lu.lv

ABSTRACT

Quality is a significant parameter for goods and services. Quality is hard to explain, yet people do recognize it and are ready to pay more for better quality services and products. Everybody understands the term “quality” in some other manner. Traditionally, quality means an intangible concept of beauty and excellence. D. Garvin’s quality characteristics (dimensions) for goods and services provide useful arsenal of tools to be used by the author in the present research. D. Garvin’s quality characteristics for goods include performance, features, reliability, conformance, durability, serviceability, aesthetics and perceived quality. Quality characteristics of services, in their turn, include tangibles, service reliability, responsiveness, assurance, empathy, availability, professionalism, timeliness, completeness and pleasantness. The research will show what kind of quality characteristics produce an impact to the choice of services/ goods made by Latvian consumers. The aim of this paper is to examine a perceptions the dimensions of quality and customers perceptions of quality in the products and services what they purchase in order to provide a framework for a better understanding of the various dimensions of product and service quality and their impact on consumer perceptions. The methods applied in research are referential analysis of literature and survey of inhabitants (questionnaire). The tasks of the research: to provide explication of quality characteristics, to carry out a questionnaire of the inhabitants of Latvia aimed to find out, what quality dimensions determine the consumers’ perception of quality, to come to conclusions on how quality is perceived.

Keywords: *consumers, quality, goods, services*

1. INTRODUCTION

Exists some differences between goods and services. The nature of services is intangible whereas goods are tangible. Since services are intangible, measurement of service quality can be more complicated. Service quality measures how much the service delivered meets the customers’ expectations. In order to measure the quality of intangible services, researchers generally use the term perceived service quality. Perceived service quality is a result of the comparison of perceptions about service delivery process and actual outcome of service (Grönroos, 1984; Lovelock, Wirtz, 2011). J.C. Sweeney et al. analyzed whether service quality in service encounter stage affects perceived value and consumer willingness to buy. As a result of the study, they found that service quality perceptions in service encounter stage affects consumers more than product quality (Sweeney et al., 1997, p, 28). Increasing the competition in the markets has led many enterprises to consider quality as a strategic tool. The author thinks that service quality has been becoming more important and service providers should improve their service quality to customer satisfaction, customer loyalty, gain sustainable competitive advantage. The customers who are dissatisfied with a service spread their experiences to more than three other people (Horovitz, 1990). The aim of this paper is to examine a perceptions the dimensions of quality and customers perceptions of quality in the services and products what they purchase in order to provide a framework for a better understanding of the various dimensions of product and service quality and their impact on consumer perceptions. The methods applied in research are referential analysis of literature and survey of inhabitants (questionnaire).

The tasks of the research: to provide explication of quality characteristics, to carry out a questionnaire of the inhabitants of Latvia aimed to find out, what quality dimensions determine the consumers' perception of quality, to come to conclusions on how quality is perceived.

2. DISCUSSION

A quality good or service meets or exceeds the whole range of customer expectations, some of which may be unspoken. J.M. Juran pointed out that Quality is “fitness for use”. (Juran, 1974, p. 29) Quality is degree of excellence. (Oxford Dictionary, 2014) Quality is conformance to requirements. (Crosby, 1979) Feigenbaum defined Quality as the total composite product and service characteristics of manufacture, marketing, engineering and maintenance through which the product and service will meet the expectations of the customer. (Feigenbaum, 1961) Quality is a dynamic state associated with products, services, people, processes, and environments that meets or exceeds expectations and helps produce superior value. (Goetsch and Davis, 2010) The author concludes that Quality is defined by the customer, and as such will change over time, often in unpredictable ways and the Quality is associated with creating customer value. Quality is an exclusive and indistinct construct. Consumers expect quality today more than ever before. To offer quality is a demand on firms to satisfy their customers. Quality is also a benchmark to measure if the claims are maintained. For companies offering good quality often means differentiating from competitors. In other words, quality is understood as a competitive weapon (Parasuraman et al., 1985). Carvin's 8 dimensional framework initially appeared in 1985, its relevance for defining product quality is apparent given its continued use in guiding research in this area. Quality of services, in general, differs from quality of manufactured products due to its special characteristics including intangibility, simultaneity and heterogeneity (Dotchin, Oakland 1994; Ghobadian et al., 1994). Effective quality management in the service sector hinges on the management of both outcome and process elements. (S.Ting-Kwong Luk, and R. Layton, 2004) Service quality has impact on customers' behavioral responses and intention. It relates to retention of customers at the aggregate level (Woodside, Frey & Daly, 1990; Zeithaml et al., 1996). While perceived service quality is a consumer judgement (a form of attitude) and resulted from comparisons consumers make between their expectations and their perception of the actual service performance (Brady, Cronin 2011). Z.Yang and R.T.Peterson pointed out that one effective means of achieving competitive advantage and differentiating strategies involves superior service quality (Yang, Peterson, 2002). Service quality has examined customer evaluations of the overall excellence or superiority (Long, 2004). Service quality can be described as overall customer judgments and evaluations regarding the quality and excellence of service. According to these arguments, C. Santos defined service quality as the overall evaluation of service performance (Santos, 2003). A.Donabedian drew attention to 3 dimensions of service quality: potential dimension, process dimension and result dimension. (Donabedian, 1988) Potential dimension relates to the observation of structures and potentials of the service provider (management, resources-material, information, human). It is influenced by activity, i.e., specification of service (description and features of service) and readiness to provide it, whereas the potential dimension does not include only technical possibilities, but also organisation and systemic relations, including qualification and motivation of employees. Process dimension captures the service as a sequence of activities (processes) consisting of the marketing process, design process and process of service provision. Result dimension relates to the assessment of the process of result of a service (satisfaction/dissatisfaction of a customer with the service or with the provider of the respective service), implying that the services reach the level of excellent quality only when they correspond with target requirements and each level of excellent quality shall correspond with the same value the customer is willing to pay as function of his/her wishes and requirements (Toivonen, 2012). Differentiates between dimensions which are associated with the quality of the final product or outcome of the service

and those which relate to internal processes within the organization. A. Ghobadian et al. considers that the importance of the process dimensions from the customers' viewpoint depends on the extent to which they participate in the process. In the manufacturing sector customers do not normally deal with production processes, however, in a service context, customers often have some participation in the process of service delivery. They are called "outcome" and "process" dimensions respectively (Ghobadian et al., 1994). Rust, R.T. and Oliver, R.L. pointed out that services can be classified into 2 categories, first in mere services which are very little or not linked to goods and second in services which are connected with the products (Rust, Oliver, 1994). Services differ from goods in many ways. The fundamental difference is intangibility. Services cannot be seen, felt, tasted or touched in the same manner in which goods can be sensed. Therefore services are an experience. Inseparability of production and consumption is another characteristic of services and involves the simultaneous production and consumption. (Owlia, Aspinwall, 1996). Products are first produced then sold and later consumed. Heterogeneity is also a typical characteristic of services. The quality and essence of a service can vary from producer to producer, from customer to customer, and from situation to situation. (Sasser et al., 1987) That makes it more difficult to standardise. Another characteristic is perishability, and means that services cannot be saved or stored. So it is difficult to synchronise supply and demand (Yuen, Chan, 2010). There are different definitions of service quality dimensions suggested in the literature, with numerous subdivisions into relevant factors of service quality C. Gronroos postulation of service quality in technical and functional quality is crucial. Technical quality involves what the customer is actually receiving from the service. (Gronroos, 2001) Functional quality or customer service involves the manner in which the service is delivered as an important factor. This subdivision is very close to the perceived service quality dimensions of D.A Aaker, which consists of product quality and service quality. (Aaker, 2011) A comparison of quality dimensions can see in Table 1.

Table following on the next page

Table 1: A comparison of quality dimensions (authors created by the Owlia, Aspinwall, 1996)

The authors	Quality dimensions
Russell, Taylor, 2003	Courtesy, Accessibility and convenience, Time & Timeliness, Accuracy, Responsiveness, Completeness,
Loiacono et al., 2002	Information fit to task, interaction, trust, response time, design, intuitiveness, visual appeal, innovativeness, flow, integrated communication, business process, and substitutability
Zeithaml et al., 2001	Access, ease of navigation, efficiency, flexibility, reliability, personalization, security/privacy, responsiveness, assurance/trust, site aesthetics, price knowledge
Brady, Cronin, 2001	Personal interaction quality, Physical service environment quality, Outcome quality
Gronroos, 2001	Attitudes and behavior, Service recovery, Reputation and credibility, flexibility and Accessibility, Professionalism and skills
Frost, Kumar, 2000	Reliability, Tangibles, Assurance, Responsiveness, Empathy
Philip, Hazlett, 1997	Pivotal, Core, Peripheral attributes
Dabholkar et al., 1996	Physical aspects, Reliability, Personal interaction, Problem solving, Policy
Johnston, 1995	Access, aesthetics, attentiveness, availability, care, cleanliness/tidiness, comfort, commitment, communication, competence, courtesy, flexibility, friendliness, functionality, integrity, reliability, responsiveness, and security
Doll et al., 1994	Content, accuracy, format, ease of use, and timeliness
Cronin, Taylor 1992	Tangibles, Reliability, Responsiveness, Assurance, Empathy
Grönroos, 1990	Reliability, Trust worthiness, Accessibility, Attitudes and behavior, Professionalism and skill, Recovery, Flexibility, Reputation and credibility
Stewart, Walsh 1989	Reliability, Accuracy, Timeliness, Understanding users' needs, Knowledge, Mistake-free, Ease of access, Competence, Courtesy and respect, Credibility, Security, Surroundings, Effective use of technology, Redress, Capacity for choice.
Parasuraman et al., 1988	Tangibles, Reliability, Responsiveness, Assurance, Empathy
Sasser et al., 1987	Condition Consistency, Attitude. Availability, Completeness, Security

According to some dimensions can be used for measuring department and specialty stores' service quality such as 5 dimensions as Policy, Physical aspects, Problem solving, Reliability and Personal interaction. The dimensions could be related to the 3 elements of services marketing mix. As a Result, Tangibles, Physical aspects, and Physical service environment were related to the Physical Environment element. Responsiveness, Assurance, Empathy, Personal interaction, and Policy were related to the People element. Reliability, Problem solving, and Outcome quality were related to Process element. The tangibles, physical aspects, and Physical service environment are related to the Physical Environment element. Responsiveness, Assurance, Empathy, Personal interaction, and Policy were associated to the People element.

Reliability, Problem solving, Outcome quality were related to Process element. D. Garvin defined 8 dimensions for quality that, as he stated, can define both product and service quality, although they appear to be more oriented to products: (Garvin, 1987)

- Reliability. Reliability, defined as the probability of a product working fault free within a specified time period, appears to be more relevant to goods than service. Dimension important to customers. Reliability involves measurable attributes. It is close association to Serviceability and Safety.
- Features characteristics that supplement the basic performance functions are called features. The author think that, drawing a line to separate performance characteristics from features is often very difficult
- Performance is concerned with the primary operating characteristics of a product. Such as, the performance of a television set comprises sound, natural colors and picture clarity. Product performance measured by conducting defined tests & experiments during R&D.
- Serviceability concerned with repairs and field services, might seem to be synonymous with durability, but more consistent with products. An aspect of this dimension is appropriate for relates to customers' complaints. The way in which an institution handles complaints from clients, staff, idustry, government, etc. can be considered as another measure of quality in the sector. Requires strong customer service department. (University of Cambridge 2012)
- Durability as a measure of a product life, looks less meaningful in this instance. Measure of product life: Amount of time of use one obtains from a product before it physically deteriorates. Measured by assessing historical information concerning product life and controlled life testing.
- Aesthetics is subjective to the customers' opinions. Aesthetics can be distinguished from performance as it is a matter of personal judgement (How the product looks, feels, sounds, tastes or smells, a matter of personal preferences).
- Perceived quality is subjective category of the customers' opinions. Consumers can be compared with the corporate and the functional categories of dimensions. Perceived quality refers to the reputational factors influencing the customers' image of the enterprises. Considering the importance of the subjective dimensions in the quality (based on image, brand name, or advertising rather than product attributes and, of course, is subjectively assessed) of service.
- Conformance refers to the extent to which a product meets established standards/specifications. Product Conformance measured by simulations and experiments against design drawings and specifications.

N. Tamimi, R. Sebastianelli pointed out that quality managers cited, among other responses, Garvin's dimensions of "reliability", "aesthetics," and "performance" when answering the open-ended question "how is quality defined in primary place of employment?" (Tamimi, Sebastianelli, 1996, p. 30). S. Ahire et al. to examine the effects of integrated quality management strategies on a company's product quality, 4 of Garvin's dimensions (performance, reliability, conformance and durability) were used in measuring the "product quality" construct. (Ahire et al., 1996) A causal relationship exists between multivariate constructs of quality (i.e. customer satisfaction, employee satisfaction, and employee service quality) and organizational performance, use "price," "product features" and "product reliability" as some of the key indicators to operationalize the "customer satisfaction" construct (Madu et al., 1997). Quality dimensions divided into 3 groups: corporate image, technical quality and functional quality. (Grönroos, 2001, p.102) Quality dimensions, can classified: physical quality, corporate, interactive quality. The dimensions associated with technical quality are those that can objectively be measured regardless of customers opinion, while those concerned with functional quality are related to the interaction between the provider

and recipient of the service and are often perceived in a subjective manner. The author thinks, that technical quality is about customer evaluations about the service. The corporate image dimension relates to the overall picture of an organization perceived by the customers; it is the result of a combination of technical and functional and quality dimensions as well as factors like the reputation of the company and the price of the products or services. (Lehtinen, Lehtinen, 1991). Corporate image has a positive impact on customer perceptions. Functional quality which is more important variable for consumer perceptions and service differentiation than technical quality refers how consumers take the service. Within the framework of the research, the author carried out a structured data collection through inquiries, which resulted in answers collected from 371 respondents from all over Latvia. The inquiry took place in November 2017. 58.76% women and 41.24% men participated in the inquiry, 21.83% respondents were aged between 18 and 27, 14.82% were aged between 28 and 37, 15.09% were aged between 38 and 47, 15.90% were aged between 48 and 57, 14.82% were aged between 58 and 67, and 17.52% older than - 67. As for the regional allocation, 42.27% of respondents came from Riga and Riga district, 18.51% from Latgale, 14.36% from Vidzeme, 13.54% from Kurzeme and 11.33% were from Zemgale region. The author wished to find out was if the quality of goods and services mattered to respondents. Respondents express their subjective opinion, showing their individual perception of quality which tends to differ to large extent. According to the results of the inquiry, 75.2% of the respondents consider quality important, 21.29% said that it is not always important, 1.35% of the respondents told that only the quality of goods mattered, meanwhile 2,16% answered that quality was not important to them. Among the possible answers, there was also a variant stating that only the quality of services is important, but none of the respondents chose it. Three quarters of the respondents admitted that for them the quality of goods and services was important. The analysis of the results show that 83.03% of women consider important the quality of goods and services meanwhile among the men the proportion was lower, only 64.05% of all respondents. The second position among the possible answers was “not always”, and the proportion of respondents included 15.14% of women and twice as much or 30.07% of men. The author tried to find out, what exactly meant the concept “high-quality service” to respondents in order to see the source of the subjective opinion of the respondents. 15.47% of the respondents told that they associate the concept “high quality service” with highly qualified employees, 15.22% – kind attendance, 15.14% mentioned the reliability of the service provider, 14.98% – the service that complies with existing requirements, 11.09% mentioned positive previous experience, 9.96% - fast service, 8.66% - high price, meanwhile good location was less relevant – 5.02%. The latter explains that mostly there are no problems with the location, since the entrepreneurs, who offer any services, strive to be available easily. Tasteful interiors, however, received low evaluation – 4.29% only. In this question the variant “Other” was also used, indicating “the price that complies with consumer requirements” constituting 0.16%, respectively. Author concludes that the system of medical care in Latvia is not properly arranged; therefore, respondents tend to pay a particular attention to this sector, since every person in Latvia has had some health issues accompanied with complaints rooted in the lack of state funding and necessity of reform in the industry. According to the inquiry results, the second most important category of services was education, where the quality is what really matters, because the unemployment directly relates to the consequences of economic crisis, the educational system of the country, the policy of employment as well as skills and knowledge of people. Construction took the third position, where the quality is what really matters, because Latvians wish to live and work in comfortable and safe premises. 3 most important categories of services in gender-specific perspective according to the opinion of respondents, who told that the quality is the most important element can see Figure 1.

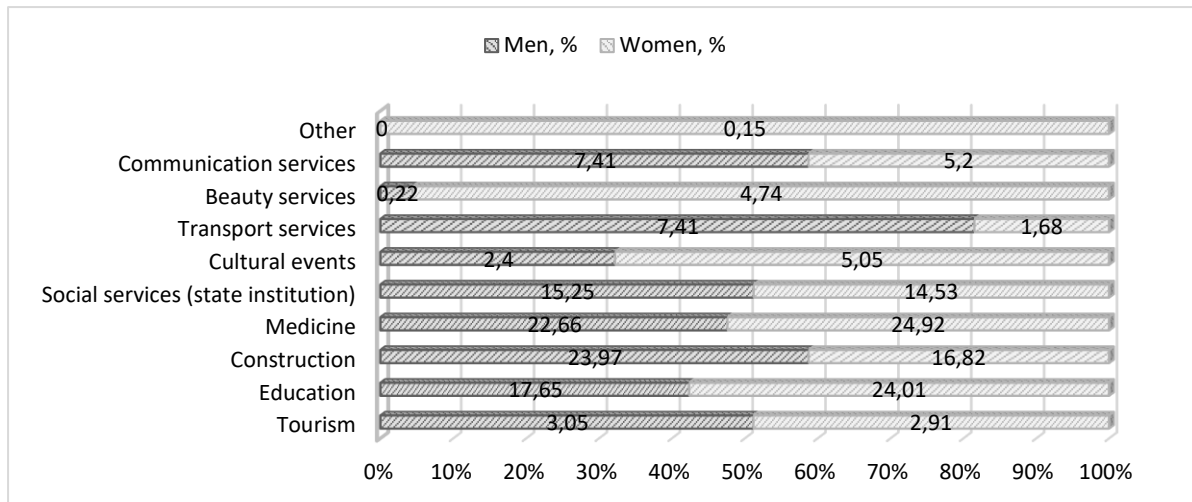

Figure 1: Three most important categories of services in gender-specific perspective according to the opinion of respondents, who told that the quality is the most important element [created by the author]

The Men, in their turn, mostly chose construction as the answer reaching 23.97%, followed by medicine with 22.66% of all male respondents. The largest part - 24.2% of the women chose medicine meanwhile almost the same number – 24.01 % chose education. The following question asked by the author, had to indicate, how the quality characteristics of the service affect the choice of a particular service provider. The respondents evaluated each quality characteristic in scale 1 to 5, where 1 was – “do not affect at all” 2 – “rather do not affect”, 3 – “neutral”, 4 “rather affects” and 5 – “affects”. The answers received show that the largest part of the respondents are influenced by professionalism, namely 4.18 %, followed by assurance with 4.15, but the smallest part of the respondents chose “rather provided some impact, and “tangibles” received 3.29 points out of 5 (see Figure 2).

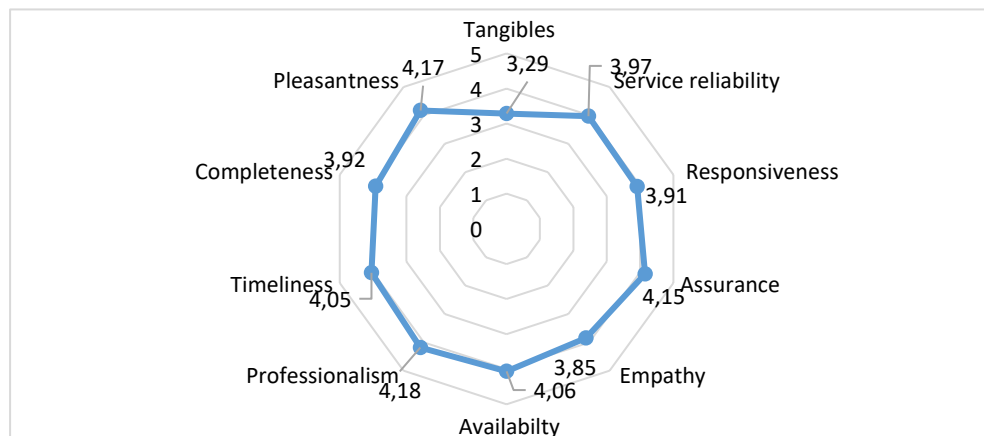

Figure 2: Impact of the quality dimension to the choice of particular services providers, points [created by the author]

The collected data leads the author to conclude, that the largest part of respondents ticked 4 points out of 5, which means that almost each of the quality characteristics matters in choice of the service. Professionalism received 4.10 points, showing that it is the most important quality characteristic for the choice of the service among the respondents. This emphasizes the importance of the customer service in Latvia, because the satisfaction of the customer depends on professionalism of the service provider. The communication quality and professional attitude significantly influence the feeling of comfort of the customer.

See the evaluation of the impact of quality characteristic choosing a particular service provider in gender-specific perspective below in Figure 3.

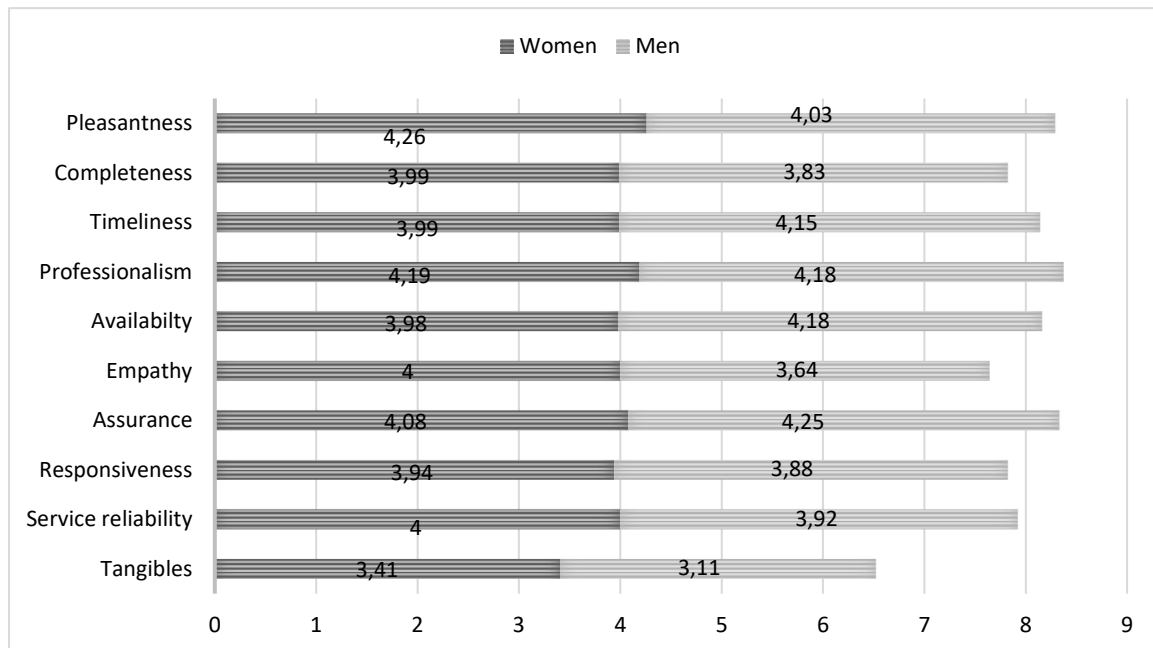

Figure 3: The evaluation of the impact of quality dimension choosing a particular service provider in gender-specific perspective [created by the author]

According to the collected data, women highly evaluate the pleasantness, reaching 4.26 points out of 5, which is the highest rate of characteristics ticked by women. Men evaluate pleasantness with 4.03 points in fourth position of significant impact. The dominant quality characteristic for men is assurance, evaluated with 4.25 points. Women evaluate assurance with 4.08 points in third position of significant impact. The largest difference between evaluations provided by women and men appears in empathy (individual attitude, customer care), 4 points ticked by women and 3.64 by men. Significant difference in evaluations – 3.41 points by women and 3.11 points by men appears in tangibles (premises, equipment, facilities etc.). In addition, men indicated availability (location) to be more important in comparison to women – 4.18 points and 3.98 points, respectively. Other evaluations of quality characteristics are not significantly gender-specific. The author to find out what exactly means “high-quality goods” for the respondents. The first question asked by the author was, what the notion “high quality goods” meant to the respondents, to find out their personal opinion. For the majority of respondents, namely, 29.87%, the concept “high-quality goods” meant a properly manufactured product, for 21.28% it meant high price, 20.56% – the compliance with the existing requirements. Only few respondents – 6.65% associate the concept “high-quality goods” with local manufacturers. 28.93 % of all respondents ticked “Food” as the most important category of goods. The next most important category ticked by 18.06% of respondents was “Medicine goods”. With 15.81% points, “Wear, shoes and accessories” take third position in the row. “Transport” was ticked by 8.81 %, “Beauty products” – 7.19 %, “Children's goods” – 6.20 %, “Phone and computer” – 5.12 %, “Household goods” – 4.58 %, “Furniture” – 3.68 %, but the last position among all categories of goods ticked by the respondents was “Presents” – 1.53 %. In all categories appeared also the answer “Other”. As for the offered categories of goods, according to the inquiry the most important categories in terms of quality are following food, medicine goods and wear, shoes, accessories. These categories are set priorities due to their impact to the health and the fact, that they are necessity goods.

For women and men the most important categories of goods are food, medicine goods and wear, shoes and accessories. A significant difference appears in cosmetics and beauty products, mostly ticked by women, since they pay more attention to their appearance, meanwhile men ticked transport as a significant category of goods in terms of quality. The aim of the following question asked by the author was to find out the evaluations of quality importance in different food categories. The respondents had to evaluate each of food categories in points from 1 to 5 (1 – unessentially, 2 – rather unessentially, 3 – neutral, 4 – rather important, 5 – important). Respondents ticked dairy products, eggs, cheese as the most important food categories, reaching 4.7 points out of 5. The following category with a tiny 0.01 points difference is meat products with 4.69 points, followed by fish and seafood with 4.58 points and fruits and vegetables with 4.56 points. Bread appears in next position with 4.4 points, salads with 4.25 points, canned products with 4.2 points and cereals, pasta and oils with 4.07 points. According to the scores, author concludes that perishable products (dairy products, eggs, cheese, meat, fish, fruits and vegetables) with shorter term to expiry date are considered more important, since the consumption of expired products can produce harmful effect to human health. The lowest score reached in category of drinks and alcohol means that these are not necessity goods. Men, consider meat products the most important category of food. It leads to conclusion that men are involved in physically hard work more in comparison to women, and they need twice as big ration of proteins. Besides, it indicates that the best way to receive more proteins is to eat meat, providing power and energy for the body, which is the reason, why men consider this category important in terms of quality. The women tend to take care of health of themselves and their families and healthy lifestyle, understanding the importance of balanced healthy food. The author analyzed the impact of quality characteristics of goods to choice made by consumers evaluated form 1 to 5 (1- no impact, 2 – rather insignificant impact, 3 – neutral, 4 – rather significant impact, 5– significant impact). The category “conformance” gained the highest score – 4.54 points, since the consumers wish the goods ordered meet their expectations. The next in turn is durability with 4.47 points, because the consumer expects the product to serve as long as possible. Very important position is reliability with 4.37 points, because positive previous experience with a particular product or manufacturer increases the possibility that the consumer will purchase a product by this manufacturer again. Nowadays, when different kind of goods is easily available, also the performance matters – 4.22 points. Women with 4.52 points, and men with 4.58 points gave the highest score to Conformance. Among women the reliability take second position (4.42 points) and durability (4.41 points) is third. Among men, durability appears in the second position with 4.55 points and reliability with 4.31 points in third position. A natural difference uncovers between women and men regarding the aesthetic or sensory characteristics (taste, flavor, appearance, sound) and such characteristic as perceived quality, because women pay more attention to the details as well as evaluate the compliance between their expectations and the received product as for taste, flavor and appearance of the product. Women tend to dedicate more time to examine the image and reputation of the manufacturer as well.

3. CONCLUSION

1. According to observations of respondents, the attending employees often lack knowledge and interest regarding the quality and ability to help customers with necessary answers to their questions, which to a certain degree is the effect of long working hours and low salaries. Subsequently, the customer often faces unkind attitude, dissatisfaction and fail to respond to the customer in case of problems or complaints related to goods and services.
2. According to the opinion of respondents, the most important categories of goods, where the quality is of core importance are food, medicine goods, wear and shoes. These are categories of goods influencing the health and/or are necessity goods. Product quality is particularly

important for dairy products, eggs, cheese, meat, fresh fish, seafood, fruits and vegetables, in general perishable goods with short expiry dates to take into account in order to avoid health problems. The impacting factors regarding the perception of quality of goods among the inhabitants of Latvia are gender and age.

3. According to survey women pay more attention to kind attendance since they are more emotional and care about personal approach, individual attitude in services, meanwhile men pay more attention to reliability of service provider, because they prefer to choose a company of good reputation based on positive previous experience.
4. For men, the quality matters most in construction, probably because men are more worried about the condition of dwellings, buildings and surroundings but for female respondents quality particularly important in medicine services. Among the inhabitants of Latvia, the most important quality characteristic is professionalism, since it impacts the choice of service provider and can directly influence the level of customer satisfaction.
5. According to survey the inquired female respondents pay more attention to aesthetic or sensory characteristics (flavor, appearance, sound, taste) and “perceived quality” than men, because they are more interested in detail and tend to assess to what degree the received goods and services comply with their expectations regarding the taste, the flavor or appearance of the respective product.
6. As for customer service, two separate groups are analyzed – goods and services. The results highlight importance of the customer service in both industries. Customer service is important in consumer markets, because it enriches the product in different ways and influences the perceived quality. In service industry, the customer service is a part of the perceived quality; more precisely, it stands for functional quality.
7. The enterprises should organize regular employee trainings about the products/services they sell and in customer attendance in order to ensure highly professional performance, which is very important quality characteristic according to the opinion expressed by the respondents.

LITERATURE:

1. Aaker, D.A. (2011). *Marketing Research*. 10 th Edition, Publisher Wiley, 2011.p 701.
2. Ahire, S. L., Golhar, D. Y., and Walter, M. A. (1996). *Development and validation of TQM implementation constructs*. Decision Science. Vol. 27(1), pp. 21–56
3. Brady, M.K., Cronin, J.J. (2001). *Some new thoughts on conceptualizing perceived service quality: a hierarchical approach*. The Journal of Marketing, pp. 34-49.
4. Donabedian, A. (1998). *The quality of care. How can it be assessed?*. US National Library of Medicine. Vol.121(11), pp. 1145-50.
5. Dotchin, J.A., Oakland, J.S. (1994). *Total Quality Management in Services: Part 3: Distinguishing Perceptions of Service Quality*, International Journal of Quality & Reliability Management. Vol. 11(4), pp. 6-28,
6. Crosby, P.B. (1979). *Quality is Free: The Art of Making Quality Certain*, New York: McGraw-Hill.p. 309
7. Feigenbaum, A. (1961). *Total Quality Control*. McGraw-Hill. New York, p.627
8. Garvin, D.A. (1985). *What does product quality really mean?* Sloan Management Review. pp. 25-43.
9. Garvin, D.A. (1987). *Competing on the eight dimensions of quality*. Harvard Business Review. Vol. 65(6), pp. 101-9.
10. Ghobadian, A., Speller, S. and Jones, M.(1994). *Service quality: concepts and models*, International
11. Journal of Quality & Reliability Management. Vol. 11(9), pp. 43-66.

12. Goetsch, D.L. & Davis, S.B. (2010) *Quality Management for Organizational Excellence: Introduction to Total Quality*. Pearson, NJ.
13. Grönroos, C. (1984). *A service quality model and its marketing implementations*. European Journal of Marketing. Vol. 18(4), 1984, pp. 36-44.
14. Grönroos, C. (2001). *The perceived service quality concept – a mistake?* Managing Service Quality. Vol. 11(3), pp. 150-152.
15. Horovitz, J. H. (1987). *How to Check the Quality of Customer Service and Raise the Standard*. International Management, Vol.1 (1), pp.25-36
16. Horovitz, J. (2006). *Putting Service Quality into Gear*. Vol 8(20), pp. 249-265
17. Juran, J.W. (1974). *Quality Control Handbook*, WcCraw-Hill, 3 rd Ed. New York, p. 1600
18. Juran, J.W. (1995). *Managerial Breakthrough: The Classic Book on Improving Management Performance* Rev Edition. McGraw-Hill, Inc. p. 451
19. Lehtinen, U. and Lehtinen, J.R. (1991). *Two approaches to service quality dimensions*, The Service Industries Journal, Vol. 11(3), pp. 287-303.
20. Luk, Ting-Kwong & Layton, R. (2004). *Managing both Outcome and Process Quality is Critical to Quality of Hotel Service*, Total Quality Management & Business Excellence, 15:3, pp. 259-278
21. Long, M, McMellon, C, (2004). *Exploring the determinants of retail service quality on the Internet*. Journal of Services Marketing, Vol. 18(1), pp.78-90,
22. Lovelock, C.H., J. Wirtz, (2011). *Services Marketing: People, Technology, Strategy*, 7th edition Prentice Hall, p. 639
23. Oxford Dictionary, (2014). Retrieved from [22.04.2018].
<https://en.oxforddictionaries.com/definition/us/quality>.
24. Owlia, M.S., Aspinwall, E.M., (1996). *A framework for the dimensions of quality in higher education*. Quality Assurance in Education, Vol. 4 Issue: 2, pp.12-20
25. Madu, C. N. and Madu, A. A. (2002). *Dimensions of e-quality*. International Journal of Quality & Reliability Management. Vol. 19(3), pp. 246-58.
26. Madu, C., Kuei, C. and Lin, C. (1997). *A comparative analysis of quality practice in manufacturing firms in the US and Taiwan*. Decision Sciences. Vol. S6(5), pp. 62-76
27. Owlia, M. S., Aspinwall E M. (1996). *A framework for the dimensions of quality in higher education*. Quality Assurance in Education, Vol. 4(2), pp.12-20
28. Parasuraman, A., Zeithaml, V.A. and Berry, L.L. (1985). *A conceptual model of service quality and its implications for future research*. Journal of Marketing. Vol. 49(3), pp. 41-50.
29. Parasuraman, A., Zeithaml, V.A. and Berry, L.L. (1988). *SERVQUAL: a multiple-item scale for measuring consumer perceptions of service quality*. Journal of Retailing. Vol. 64(1), pp. 12-40.
30. Pirsig, R.W. (1999.) *Lila Inventory into Morals*, Bantam Books, New York, NY. p. 480
31. Richard, M.D. and Allaway, A.W. (1993). *Service quality attributes and choice behavior*. Journal of Services Marketing. Vol. 7(1), pp. 59-68.
32. Rust, R.T. and Oliver, R.L. (1994). *Service Quality Insights and Managerial Implications from the Frontier*. Sage Publications, Thousand Oaks, pp. 1-19.
33. Santos, J. (2003). *E-service quality: a model of virtual service quality dimensions*. Managing Service Quality: An International Journal. Vol. 13(3), pp.233-246,
34. Stewart, J. and Walsh, K. (1989). *The Search for Quality*. Luton Lokal government, Training book, p. 281
35. Sweeney, J. et al. (1997). *The role of perceived risk in the quality-value relationship: A study in a retail environment*. Journal of Retailing. Vol 75(1), pp. 77-105

36. Tamimi, N. and Sebastianelli, R. (1996). *How firms define and measure quality*. Production and Inventory Management Journal. Vol. 37(3), pp. 33-39.
37. University of Cambridge. (2016). *Quality Framework*. Retrieved from [27.04.2018] <https://www.ifm.eng.cam.ac.uk/research/dstools/quality-framework>.
38. Woodside, A.G., Frey, L.L. and Daly, R.T. (1990). *Linking service quality, customer satisfaction, and behavioral intention*. US National Library of Medicine. Vol 9(4) pp.5-17.
39. Yang, Z. and Peterson, R.T. (2002). *The quality dimensions of Internet retail food purchasing: a content analysis of consumer compliments and complaints*. Journal of Foodservice Business Research. Vol. 5(2), pp. 25-46.
40. Yuen, E.F.T., Chan, S.S.L. (2010). *The effect of retail service quality and product quality on customer loyalty*. Journal of Database Marketing & Customer Strategy Management 17 (3), pp. 222-240.
41. Zeithaml, V.A. (1987). *Defining and Relating Prices, Perceived Quality and Perceived Value*, Marketing Science Institute, Cambridge, MA
42. Zeithaml, V.A et al. (1996). *The Behavioral Consequences of Service Quality*. Article in Journal of Marketing. Vol. 60 (4), pp.31-46

METHODS OF CONSTRUCTION DURATION ESTIMATION

Irina Azarova

Odessa State Academy of Building and Architecture, Ukraine

azarovairene@gmail.com

ABSTRACT

This publication is devoted to topical issues of estimating the construction duration in time management in construction. The aim of the study is to analyze normative methods of estimating the construction duration, used at design and construction executive documentation developing. This aim is very important in terms of project management for selecting the most optimal methods of estimating the construction projects duration. Based on DSTU B A.3.1-22, SNiP 1.04.03-85 and DSTU B A.3.1-5, several principal methods of duration estimating were analyzed. Also, an assessment of the available methodologies accuracy and consistency was made. The study shows, that the techniques proposed in the normative literature have a number of significant drawbacks for their application in time management. The method of construction time estimating by averaged indicators, which used in Draft design, Feasibility Study, does not take into account a number of significant features of construction projects and performing organizations. Nevertheless, this technique can be used for a duration analysis in the initial stages of the project and business planning. The method of determining the construction duration, which based on the calendar plan, requires methodological refinement to the implementation of the "triple constraint" principle of project management. This principle allows to select the most optimal time, cost and work content and ensure the required quality of the project result with minimal resources outcomes. The obtained research results can be used by project managers when selecting methods for time management of investment and construction projects at various stages of project planning. The further research is possible to provide in the development of a method for estimating construction terms based both on the normative documents requirements and on modern project management methodology.

Keywords: *evaluation of construction duration, management of projects in construction, project time management*

1. INTRODUCTION

According to one of the project definitions used in the project management methodology, the project is a time-limited event aimed to creating an unique result. The project definition in project management includes "papers", actions, resources and results which is necessary to achieve the project's goals. The "paper" includes design and budget documentation for construction and other documents, such as project charter, business plan, project management standards, etc. A result of a commercial project, for example, includes more than constructed building, but also a successfully operating business with generated income. That's why projects in project management can't be completed with putting a building into operation, like it is in construction. Achievement the project objectives usually includes obtaining the planned profit from the operation facility. Despite a number of differences in the understanding of construction projects and projects in project management, the issue of assessing and scheduling of project activities is equally relevant for both construction and project management. Such Ukrainian scientists as Burykh G.M. [1] Dadiverina A.V. [2] VM Kirnos [3] and others were involved in the study of construction projects management, including the planning of their terms. Among foreign researchers of this subject are Dokuchaev A.V. [4], Kuznetsov S.M. [5], Kurchenko N.S. [6], Lapidus A.A. [7], Mishchenko V.Y. [8], Ptukhin I.A [9], Rizvanov D.A. [10] and many others. An analysis of these and some other publications in the field of the research shows that the methodological approaches to construction time estimating presented mostly by

methods and approaches formed in the Soviet Union age. These methods were actual in the middle of the last century but do not correspond to the modern methodology of project management. Therefore, the purposes of the study are to analyze the existing in regulatory documents methods of estimating the construction work duration to use in developing design, technological and executive documentation for construction, to assess the advantages and disadvantages of available techniques for selecting the most optimal methods for estimating the investment and construction projects duration.

2. METHODS OF DETERMINING THE DURATION OF CONSTRUCTION

In Ukraine the official methodological basis for estimating the construction duration is DSTU B A.3.1-22 "Determining the duration of construction of facilities" [11]. This document describes methods for determining the planned duration of new construction including preparatory work for various facilities during the development of design project. The choice of methodology depends on the design stage and the available raw data.

2.1. Determination of the construction duration by averaged indicators

At the initial stages of design (Sketch design, Feasibility study) with the lack of the necessary initial data, the duration of construction can be determined based on the averaged indicators, or based on SNiP 1.04.03-85 "Norms of the duration of construction and backlog in construction of enterprises, buildings and structures" [12]. The averaged indices of building duration given in annex A of this document were determined on the basis of generalized statistical data in similar constructed facilities in our country. This basis objects are monofunctional buildings, which significantly reduces the available methodology possibilities in determining the duration of the construction of multifunctional buildings, such as shopping and entertainment centers, resort and recreation complexes, etc. According to the proposed method, special coefficients are used to calculate the influence on construction duration of some unique object conditions, such as its design features, organizational and technical parameters of building process (represented exclusively by the working shifts). At the same time, the most important features stay ignored, such as the organizational structure of management of the building company, its level of innovative development, individual production capabilities, etc. Although, for example, the significant influence of the organizational management structure to the indicators of reducing labor intensity of work, reducing the loss of working time, and much more are confirmed in the studies of Baulin A.V. [13]. The impact of quality management systems introduction on reduce labor costs, to eliminate defects in work and reduce the reserves of capacity in construction is presented in the researches of Manoha S.E. [14]. The innovations implementation in construction is given in the introduction to the normative document [11] as one of the main reasons for the necessity to revise the methods for determining the duration of construction. The normative document has also lacks data on the error of this method and actually obtained values of the duration of building construction. All this allows us to conclude that the method of the construction duration definition based on the averaged indicators which uses at the early stages of project planning is rather arbitrary. It does not take into account a number of important project's and executing organization's features, which are important and significantly affecting the duration of work. Nevertheless, this technique can be used for an integrated analysis of construction duration at the initial stages of the project and in business planning.

2.2. Determination of construction duration on the basis of a calendar plan for the development of a construction organization project.

In the subsequent stages, during developing of the Project stage (or the approved part of the Work Project), the duration of the construction is determined in the section of the project

documentation "Construction Management Project". The project of the building process organization (hereinafter - the PCO) is a kind of design and technological documentation in the project that contains decisions of the building process organization of the facility as a whole and, if it is necessary, the decisions of queue, launch complex, separated part, part of the construction site, preparatory works [15, 2]. The PCO is developed by the general design organization with the involvement, if it is necessary, of other design or research organizations to develop separate sections of the project. For overhaul, reconstruction, technical re-equipment of the existing facility, the PCO is being developed with the involvement of the customer. Contracting organization, as a rule, does not participate in the development of PCO. In PCO the total duration of construction, as well as the duration and sequence of individual stages execution of work are determined by scheduling in accordance with the requirements of DSTU B A.3.1-5 [11], taking into account the list and scope of work, their technological and organizational relationship. The initial data for determining the construction duration is provided by analog projects, which are having similar characteristics, volumetric planning and constructive solutions, directive constraints of the customer, etc. The Gantt chart (with the project critical path displayed), the cyclogram and the network diagram in the form of a chart diagram are recommended forms for schedule planning in the normative document [11]. In project management this technique has the following disadvantages of its use.

1. Binding to analog projects, which were executed in other conditions by other organizations with specific management systems, causes many errors in estimating the duration of construction. The reasons for these errors were described in paragraph 2.1.
2. The evaluation of the work duration is done according to the indices of their machine capacity and labor intensity, without reference to the production capabilities of the existing construction organization with its availability of the types of construction machinery and mechanisms, the quantity and qualification of its labor resources. At this stage of the project documentation development, the builder isn't selected by the customer yet, therefore the necessary initial data for the correct development of the PCO are not provided to the designers. That's why the estimation of the work duration is approximate again, but it happens now at the investment stage of the project.
3. This method allows the customer to set overall project duration limit only by its directive restriction, which does not correspond to the modern methodology of project management. Also, in this methodology, the principle of "triple boundedness" of projects is not implemented at all.

This principle also called the "Project Management Triangle" allows to link project time limitations with restrictions on the works content and cost, as well as quality. In the proposed methodology, the schedule planning is tied only to the list of works and is carried out in isolation from the project cost planning. The budget estimations are made separately from the planning of the construction process and its timing, although it is linked by the final section of the PCO and other sections of design project. The indicators of project result quality and the performance of construction, installation, finishing and other works are considered only at their minimum level - compliance with regulatory requirements, without the possibility of establishing any higher level of quality parameters by the customer. Determination of the construction duration in the PCO development based on the calendar plan requires a methodological supplement that will allow to link all four parameters to select the optimal time, cost and content of works and ensure the required quality of the project result with minimal resource costs. At least, the methodology requires improvements related to an enlarged account ability of the organizational and production capabilities of the general contractor building organization.

2.3. Estimating the construction duration in the development of a project for the works execution

The project for the works production (hereinafter to PWP) is a kind of design and technological documentation developed on the basis of working documentation and a project of the building process organization, which is determines and details the technology, organization and conditions for performing construction work [14, p.3]. PWP is developed by a building organization for the types and stages of work that it performs. The basis of PWP developing is working documentation and PCO. PWP should provide the measures to ensure high-quality, safe and time limits of work. The characteristics of materials and structures, the involved construction machinery, equipment, technical facilities, and the conditions for performing the work are taken into account when developing the PWP. The PWP includes a schedule plan of work that can be built on the basis of a network schedule. The schedule establishes the sequence and time limits of the work with the maximum possible combination. All of the local schedules for the receipt of building structures, products, materials and equipment are made on the basis of the main schedule with the addition of completing statements. The methodology for construction time estimating used in the PWP design takes into account the organizational and other features of the building organization. It allows obtaining minimum deviations of the planned construction dates from the actual ones. Nevertheless, the principle of "triple boundedness" is not realized at this stage either. Excessive detailing of the initial data which is necessary for the PWP development, as well as the considerable work effort and duration of this documentation development, make it impossible to use this method for the project manager in carrying out the pre-project analysis.

3. CONCLUSION

Existed methods for estimating of construction duration described in the Ukrainian regulatory literature and used to develop the design and technological executive documentation, have a number of shortcomings when they are applied to time management of projects. Determining the construction time by averaged indicators is very approximate; it does not take into account a number of projects features and their organizations that significantly affect the duration of the work. Estimating the construction duration on the basis of a calendar plan in the development of PCO and PWP requires methodological refinement in the implementation of the "triple-limited" project principle for selecting the most optimal time, cost and content of works and ensuring the required quality of the project result with minimal resource costs. The obtained research results can be used by project managers when selecting methods for time management of investment and construction projects at various stages of project planning. A promising area for further research in the field of methodology for duration estimating of investment and construction development projects is the forming of a method for estimating construction duration based both on the requirements of normative documents and on modern project management methodology.

LITERATURE:

1. Burih G. M., ShilIn I. V., Gritsuk Yu. V. (2014) Calculation of the duration of repair and restoration works on highways using MS EXCEL, Bulletin of the DNABA. Donetsk: DNABA. Pp. 39-41.
2. Dyachenko Yu.T., Didaverina A.V. (2015) Problems of reducing the duration of construction, Collection of scientific papers. Construction, materials science, machine building. Vol. 81. Dnipro: GVUZ "Pridnepr. State. Academy of building and architecture". Pp. 93-98.

3. Kirnos V. M. (1994) Scientific and methodological principles of organizational and technological regulation of the duration and cost of reconstruction of industrial enterprises (dis. ... Dr. techn. Sciences: sp. 05.23.08) Retrieved 11.04.2018 from <http://lib.ua-ru.net/diss/cont/258829.html>
4. Dokuchaev A.V., Kotenko A.P. (2007) solution of the task of production scheduling in conditions of stochastic uncertainty of parameters, The bulletin of the Samara State Technical University. Series: physics and mathematics. Vol. 2(15). Samara:SSTU. Pp. 182–183.
5. Kuznetsov, S.M. (2015) Increasing the efficiency of machinery and mechanisms in construction: monograph. M. Berlin: Direct Media. 203 p.
6. Kurchenko N.S., Alexeytsev A.V., Galkin S.S. (2016) Method for determining the duration of construction on the basis of evolutionary modeling taking into account random organizational expectations, MGSU Bulletin. Vol. 10. Moscow: MGSU National Research University. Pp. 120-130.
7. Lapidus A.A. (2013) Influence of modern technological and organizational measures on achievement of planned results of construction projects, Technology and organization of construction. Vol. 2 (3). Moscow: MGSU. P.1.
8. Mishchenko V.Ya., Emelyanov DI, Tikhonenko A.A. (2013) Development of a methodology for optimizing the allocation of resources in the scheduling of construction based on genetic algorithms, Industrial and Civil Engineering. Vol. 11. Moscow: Publishing house PGS. Pp. 76-78.
9. Ptukhin I.A., Morozova T.F., Rakova K.M. (2014) The formation of the responsibility of the construction participants for violation of the calendar deadlines for the execution of works using the Pert method, Construction of unique buildings and structures. Vol. 3 (18). SpB: St.Petersburg Polytechnic University and Production, research and design institution "Venchur". Pp. 57-71.
10. Rizvanov D.A., Popov D.V., Bogdanova D.R. (2008) Application of Distributed Artificial Intelligence Technologies for the Solution of Scheduling Problems, Information and Mathematical Technologies in Science and Management: Materials of the XIII Baikal conf. chapter 2. Irkutsk: ISEM SB RAN. Pp. 76-82.
11. Determination of the duration of construction of objects. (2013). DSTU B A.3.1-22: 2013. Retrieved 11.04.2018 from http://dbn.co.ua/load/normativy/dstu/dstu_b_a_3_1_22/5-1-0-1109
12. The norms of the duration of construction and encumbered in the construction of enterprises, buildings and structures. (1985). SNiP 1.04.03-85. Retrieved 11.04.2018 from https://dnaop.com/html/46427/doc-%D0%A1%D0%9D%D0%B8%D0%9F_1.04.03-85_
13. Baulin A.V. (2004) Development of organizational structures of management of enterprises of the building complex (dis. ... Can. techn. Sciences: sp. 08.00.05). Penza: [Baulin A.V.]. 187 p.
14. Manokha S.V. (2002) Development of a quality management system in construction at the stage of technological preparation of production (diss. ... Can. techn. Sciences: sp. 05.15.10). Voronezh: [Manokha S.V.]. 150 p.
15. Organization of construction production. (2016). DSTU B A.3.1-5: 2016. Retrieved 11.04.2018 from <http://dbn.co.ua/load/normativy/dbn/1-1-0-294>

DETERMINANTS AND METHODS OF IMPLEMENTING LOCAL GOVERNMENT TASKS

Beata Sadowska

*University of Szczecin, Faculty of Management and Economics of Services, Poland
beata.sadowska@wzieu.pl*

ABSTRACT

Local economic development is a special category of development because it is treated as the basis for desired changes in all aspects of the life of the local community. Local governments stimulate such an economic development through the implementation of local government tasks. The research problem examined in this study is focused on the implementation of local government tasks in the context of local development. The objective of this paper is to answer the following question: What instruments coordinating the local development policy imply the implementation of local government tasks? The core research thesis states that selection of instruments for the implementation of local government tasks is determined by a variety of factors occurring at the level of an entity. Such exploration methods and techniques as: desk research, critical analysis of national and foreign literature on the subject, and expert method were used in the course of the research.

Keywords: *local development, local government, local government tasks*

1. INTRODUCTION

Poland is a signatory of the European Charter of Local Self-Government, which, like the Constitution of the Republic of Poland, stipulates that the general population within the units of territorial division is, by virtue of law, a self-governing community. Commune is a basic unit of the Polish local government. Commune performs public tasks on its own behalf and on its own responsibility. Its scope of activities includes all public matters of local significance, that is, matters that concern the public interest, social benefits, benefits of all or a significant part of the commune's population. Performance of local tasks should satisfy the needs of local communities, such as: providing social housing, sewage disposal and water supply, access to public transport or municipal waste disposal. Today, communes carry out local tasks having regard to the concept of local development. The objective of this paper is to answer the following question: What instruments coordinating the local development policy imply the implementation of local government tasks? The core research thesis states that selection of instruments for the implementation of local government tasks is determined by a variety of factors occurring at the level of an entity. Such exploration methods and techniques as: desk research, critical analysis of national and foreign literature on the subject, and expert method were used in the course of the research.

2. TASKS OF LOCAL GOVERNMENT UNITS (LGU)

Public tasks that satisfy the needs of the local self-governed community are carried out by a local government unit as their own tasks, in accordance with Article 166. 1 of the Constitution of the Republic of Poland (Miszczyk, Miszczyk, Żuk, 2007). The basic body of Polish local government in Poland is the commune authority. This is stated in Article 6 of the Act on Local Government, which says (Szypliński, 2008):

1. "the commune's responsibilities include all public matters of local importance, which are not reserved by the law to other entities,
2. unless the Act provides otherwise, the settlement in matters referred to in point 1 belongs to the commune."

The commune authority implements two groups of tasks - own and commissioned tasks. In accordance with the Article 7 of the Act on Local Government, own tasks include satisfying the collective needs of society, especially in the area of (Act of March 8, 1990):

- spatial order, real estate management, environmental and nature protection as well as water management;
- communal roads, streets, bridges, squares and traffic organization;
- waterworks and water supply, sewage system, municipal sewage disposal and treatment, cleanliness and order as well as sanitary facilities, landfills and municipal waste disposal, electricity, heat and gas supply;
- telecommunications activities;
- local public transport and healthcare;
- social aid, including care facilities;
- supporting family and foster care system;
- social housing construction;
- public education; culture, including local libraries and other cultural institutions, and protection and care of monuments; physical culture and tourism, including recreational areas and sports equipment;
- marketplaces and market halls;
- municipal greenery and tree plantings;
- public order and security of citizens as well as fire and flood protection, including equipment and maintenance of the municipal flood protection warehouse;
- maintenance of communal facilities and public facilities as well as administrative facilities;
- pro-family policy, including providing social, medical and legal care for pregnant women;
- support and dissemination of the self-government idea, including creation of conditions for the operation and development of auxiliary units and implementation of programs that stimulate civic activity;
- promotion of the commune, cooperation with non-governmental organizations;
- cooperation with local and regional communities of other countries.

The commune performs commissioned tasks in the field of government administration as well as preparation and holding of general elections and referenda. The commune also performs tasks on the basis of an agreement concluded between administrative bodies and can perform tasks belonging to a district or province on the basis of agreements with these units. Local authority is present in the lives of citizens and regions as an organizer and provider of services, public goods and as a local management body. Through the implementation of tasks, it contributes to local and regional development.

3. THE ESSENCE, OBJECTIVES AND FACTORS OF LOCAL DEVELOPMENT

The basic objective of development (in local terms) is to meet the needs of the population and improve the standard of living, while the complexity and diversity of developmental goals may cause their competitiveness or opposition, and some goals are means for other ones (Cowen, Shenton, 1996). From the perspective of historical research on development, the terms "development", "progress" and "growth" have often been combined and treated as synonyms. However, development does not necessarily mean changes related only to progress or growth. Local territorial development can be defined as "generating dynamics through endogenous factors (bottom-up, local), but not excluding external (exogenous) relations". M. Kogut-Jaworska [Kogut-Jaworska, 2008] defines local economic development as developing individual and collective entrepreneurship using local resources, which depend on many factors of a social, environmental, territorial, cultural or political nature.

E. J. Blakely and N.G. Leigh (Blakely, Leigh, 2009) suggest that local economic development should be considered a little wider. According to them, local economic development can be seen when there are actions undertaken to shape and improve the quality of life of the community in the long and medium term through social and material development processes based on the principles of social justice and sustainable development. Having regard to the scope and form of local authorities' actions, two models of the commune economic development policy can be identified – conventional policy model and community policy model. The first model, called the conventional local policy model, is based on the implementation of tasks that have been included in the framework of the functioning of local governments through real budgetary resources. The core tasks of the local government within the scope of local economic development include (Bantam, 2004):

- creating and implementing socioeconomic development strategy,
- undertaking promotional activities, sharing local resources, applying reductions, incentives, granting subsidies,
- creating own stimulation and support funds for local development or acquiring financial resources for this purpose,
- creating organizational structures for local development, within which a comprehensive and full service of local development entities is carried out,
- creating local (municipal) businesses with local capital,
- creating "work space", "business incubators",
- creating a system of education, further education and professional development.

The conventional local policy model focuses primarily on a set of instruments in the form of rules and bans as well as on the use of economic incentives or direct contacts of local government with strong economic entities operating on their territory. The second model of local development policy, called the community model, relies on including representatives of the local community in the decision making within the process of planning and implementing economic policy. The concept of this socially-oriented model of socioeconomic development policy is based on not only involving the representatives of local authorities in local initiatives and projects, but also residents, community organizations, local entrepreneurs and the business environment. The local development factors¹, among others, include (Szewczuk, Kogut-Jaworska, Zioło):

1. Natural resources and environmental values (mineral resources, climate and soil conditions, topography);
2. Labour resources (number of inhabitants, level of education, professional experience and additional qualifications);
3. Infrastructure investments (equipment and network infrastructure, network availability);
4. Economic potential. Economic potential development factors:
 - socioeconomic structure, which is defined by: economic development agencies, chambers of commerce and industry, education and training system organizations,
 - financial structure represented by: banks, development foundations, economic support funds, credit funds,
 - political structure determined by diverse types of centres and institutions of power and political activity,
 - educational structure: schools and educational institutions

¹ More in: M.Szaja, 2013, *Konkurencyjność gmin pod względem struktury przestrzennej – na przykładzie gmin nadmorskich województwa zachodniopomorskiego* [Competitiveness of communes in terms of spatial structure - on the example of the seaside communes in the Zachodniopomorskie province] [in:] *Wzrost i rozwój potencjału Europy – Inwestycje w innowacyjną i konkurencyjną gospodarkę regionów* [Growth and development of Europe's potential - Investments in the innovative and competitive economy of the regions], ed. J. Buko, 9th Local Government Forum, Zeszyty Naukowe No. 794, Economic Problems of Services No. 108, Scientific Publisher of the University of Szczecin, Szczecin, pp. 279-280.

Taking into account the quantitative and qualitative character of changes related to the development in a local perspective, there are a number of attempts to measure development in the literature. Overall, five main groups of indicators of territorial development can be identified (Levitsky, 2012):

- measurement of physical units (population, number of enterprises),
- expressed in financial terms (salary),
- measurable, but not possible to value (distance from national borders),
- non-measurable (but identifiable on the basis of subjective assessments, e.g. landscape values).

4. INSTRUMENTS COORDINATING LOCAL DEVELOPMENT POLICY

Local government as the actual host of a specific territory is responsible for the organisation, structure, functioning and development of the living environment residents, as well as an increase in competitiveness. It coordinates local development policy in its area using specific methods, tools, and resources. The implementation of the concept of economic development in a local area forces the cooperation between authority bodies, entities, people and companies. The most common forms of this cooperation include (Kogut, 2004):

- joint public private undertakings which objective is to satisfy the needs of the local community through the implementation of public utility tasks,
- commissioning various tasks to entities from the enterprise sector and non-governmental organizations,
- establishing companies with the participation of the commune and the inclusion of private capital, which results in more local tasks being implemented,
- creating support centres to boost local entrepreneurship through the creation of business support institutions, counselling, training, loans and guarantees institutions.

Instruments for (coordinating) local government bodies impact on local development can be classified according to various criteria. The most frequently used criteria include the financial criterion and the division into instruments of direct and indirect influence. Financial instruments supporting local development policy can be divided into income policy instruments and expenditure policy instruments as presented in Table 1.

No.	Group of instruments	Details
1	Income instruments	<ul style="list-style-type: none"> - subsidies from local budgets, development funds, guarantee funds, co-financing business ventures - tax credits - financial liabilities delays - differentiation of environmental protection charges - introduction of variations in: real estate tax, building land fees, land lease fees, commercial premises fees, agricultural taxes - price (fee) adjustment for central heating and hot water, landfill use
2	Expenditure instruments	<ul style="list-style-type: none"> - technical infrastructure investments (construction of water supply network, road repairs) - social infrastructure investments (renovation of social housing, construction of schools) - subsidies, loans, sureties - recapitalization of business incubators, technology parks

Table 1. Financial instruments supporting local development policy (own study based on: Kogut (2004, pp. 243-244)).

Important tools coordinating local development policy include:

- local spatial development plans (the spatial development conditions and directions studies),
- task budget (multi-annual investment plan),
- economic development strategy, local development plan,
- Balanced Scorecard,
- use of cost accounts, e.g. quality cost account, product/service life cycle cost.

The possibility of using instruments for stimulating local development are determined by specific factors, among which the most frequently mentioned (Kogut-Jaworska, 2008) are:

- having the financial capability,
- the right to develop and introduce new instruments,
- the possibility of coordinating the instruments used by other entities, that try to take action to solve a problem that has become the object of local government policy,
- external constraints resulting from a central policy in relation to a given region, commune,
- legal competences in relation to the various public entities subordinate to public authorities.

The choice of instruments for the performance of the tasks of the local government aimed at local development is determined by many various factors occurring at the unit level. Sample selection of instruments for the performance of the tasks of the local government aimed at local development is shown in Table 2.

Instrument	Small rural commune	Urban and rural commune	Large urban commune
Local spatial development plan	**2	***	***
Financing plan	***	***	***
Local taxes and fees (adjusting rates)	***	***	***
Price policy instruments (setting water and sewage disposal prices, public transport ticket prices)	***	***	***
Activity based budget	*	**	**
Economic development strategy	*	**	**
Balanced Scorecard	-	-	*
Quality cost account	-	-	**
Product/service life cycle cost.	-	-	*
Highly-qualified staff	*	**	**
Investment activities in the field of environmental protection	*	**	**
Public private partnership	-	*	**

Table 2. The choice of instruments for the performance of the tasks of the local government aimed at local development (own study)

This original catalogue of instruments for the performance of local authority tasks aimed at local development was developed as a result of the application of the expert method. Experts were town hall and commune office employees, secretaries, treasurers, spatial planning department employees in the Zachodniopomorskie and Lubuskie provinces in February-April 2018. According to the experts, the selection of instruments depends, among other things, on the size of a given commune, internal organization, quality and availability of resources, management model, type of commune (rural, urban-rural, urban). E. Schröder [Schröder, 2009] believes that the greatest mystery of economic development is the activation of the potential that lies in the local community members not by imposing on them ready-made formulas or solutions but putting at their disposal a certain space where they could pursue their own ideas and initiatives

² Application (use) of a given instrument by a particular commune type (- does not occur, * - rarely used, ** - more frequently used, *** - often used)

and to decide what actions to take in the first place. Human capital is a key instrument for coordinating local development policy. People, who can skilfully, effectively and efficiently use the remaining resources (material, capital, information), imply the implementation of local government tasks, which in effect helps implement the concept of economic development in a given local area.

5. CONCLUSION

The most important institutions for stimulating local development are communes. Local development is a complex phenomenon, dependent both on the combination of human, material and financial resources, but also on social, ecological, environmental or political conditions. Local development is a process of the expected and desired changes in the area, that is in the local social and territorial system. The research problem examined in this study is focused on the implementation of local government tasks in the context of local development. As a result of the research process carried out, based both on literature studies and desk research:

- the classification of tasks carried out by local government units was developed,
- the essence, goals and factors of local development were identified,
- recommendations for the selection of instruments for the implementation of local government tasks by a given local government unit (commune) were recommended,
- the instruments for the implementation of local government tasks were arranged according to the most frequently used criteria (income and expenditure),
- additionally, other, less frequently used tools for the implementation of local government tasks (e.g. cost accounts) were presented.

The research carried out allowed us to state that "various instruments support local development policy, imply the implementation of local government tasks, and the selection of these instruments is determined by many factors occurring at the unit level".

LITERATURE:

1. Blakely E.J., Leigh N.G. (2009). *Planning local economic development, Theory and practice*, 4th Edition, Sage Publications, Los Angeles - London, pp. 75-76.
2. Cowen MP, Shenton RW (1996). *Doctrines of Development*, Routledge, London- New York, pp. 2-5.
3. Lewicki (2012). *Wykształcenie ludności, a rozwój lokalny Bielska-Białej i powiatu bielskiego* [Population's level of education and the local development of Bielsko-Biała and the bielski district], [in:] Rosa (ed.) *Spółeczeństwo informacyjne – uwarunkowania rozwoju* [Information society - determinants of development], Zeszyty Naukowe no. 680, Management, Finances and Marketing Issues 21, Scientific Publisher of the University of Szczecin, Szczecin, p. 154.
4. Kogut M. (2004). *Polityka stymulowania rozwoju gospodarczego w gminach – aspekty teoretyczne i pragmatyczne* [Policy of stimulating economic development in communes – theoretical and pragmatic aspects], [in:] *Polska Samorządność w integrującej się Europie* [Polish Self-Government in an integrating Europe], 1st Local Government Forum, University of Szczecin Foundation, Szczecin, p. 242.
5. Kogut-Jaworska M. (2008). *Instrumenty interwencjonizmu lokalnego w stymulowaniu rozwoju gospodarczego* [Local intervention instruments for stimulating economic development], CeDeWu Publishing House, Warsaw, p.11.
6. Miszczuk A., Miszczuk M., Żuk K. (2007) *Gospodarka samorządu terytorialnego* [The economy of territorial self-government], Scientific Publishers PWN, Warsaw, p. 38.

7. M.Szaja, 2013, *Konkurencyjność gmin pod względem struktury przestrzennej – na przykładzie gmin nadmorskich województwa zachodniopomorskiego* [Competitiveness of communes in terms of spatial structure - on the example of the seaside communes in the Zachodniopomorskie province] [in:] *Wzrost i rozwój potencjału Europy – Inwestycje w innowacyjną i konkurencyjną gospodarkę regionów* [Growth and development of Europe's potential - Investments in the innovative and competitive economy of the regions], ed. J. Buko, 9th Local Government Forum, Zeszyty Naukowe No. 794, Economic Problems of Services No. 108, Scientific Publisher of the University of Szczecin, Szczecin, pp. 279-280.
8. Schröder E. (2009) *Mit der LEADER – Methode zur nachhaltigen Regionalentwicklung*, [in:] *Nachhaltige Entwicklung ländlicher Räume Chancenverbesserung durch Innovation und Traditionspflege*, ed. R. Friedel, EA Spindler, VS Reasearch, Wiesbaden, p. 75.
9. Szewczuk A., Kogut-Jaworska M., Ziolo M. (2011). *Rozwój lokalny i regionalny* [Local and regional development], Wydawnictwo C. H. Beck, Publishing House, pp. 52-64.
10. Szypliński M. (2008). *Prawne formy realizacji zadań gospodarczych i społecznych samorządu terytorialnego* [Legal forms of implementing economic and social tasks of local authorities], Scientific Society of Organization and Management, Stowarzyszenie Wyższej Użyteczności „Dom Organizatora”, Toruń, p. 13.
11. The Act of 8 March 1990 on Local Government, Journal of Laws No. 16, item 95 as amended

MBTI MODEL APPLICATION FOR THE ACMEOLOGICAL-INVARIANT ORGANIZATION MANAGEMENT AS AN INSTRUMENT FOR “BREAK-THROUGH” INNOVATIONS IMPLEMENTATION

Olena Shcherbak

Procter&Gamble

Igorevskaya Street 13/5a, Kyiv 04070, Ukraine

shcherbak.o@pg.com

Liudmyla Ganushchak–Efimenko

Kyiv National University of Technologies and Design

Nemirovich–Danchenko Street 2, Kyiv 01011, Ukraine

glm5@ukr.net

Nataliia Kulak

Kyiv National University of Technologies and Design

Nemirovich–Danchenko Street 2, Kyiv 01011, Ukraine

nkulak@meta.ua

ABSTRACT

The most urgent development strategy for Ukrainian economy lies in the “break-through” concept. This concept is based on a steep increase of innovation activities with the goal to get to the next efficiency level. The key to success of this model is an optimal use of highly qualified workforce, technology innovations, efficient infrastructure and integration into a global market system. The goal of this research is to develop a method of MBTI model implementation to create an optimal structure of an acmeological-invariant Organization management as an instrument of “break-through innovations” incorporation. A complex system of a project group creation is represented in the research. Its goal is to initiate and successfully realize “break-through innovations”, based on the example of JSC “Pharmaceutical company Darnitsa”. A described system is based on the realization of a 4-phase algorithm. The goal of acmeological-invariant Organization management structure development is to obtain such an organization structure, where an interaction between its separate elements will lead to a new level of an overall organization development. An economic-mathematical evaluation was conducted in order to identify project group members interaction efficiency (according to their new project roles). The purpose of this evaluation is an empirical relationship validation between new structure components relevance. As a next step, a clusterization of possible staffing combination variants of the project group was carried out, it was based on the results of the evaluation of interaction level between project group members according to their functional responsibilities. The choice of the most optimal organization structure was done with the help of ANOVA toolkit. A conducted research proves that the application of MBTI model is a logical continuation of the process called to amplify and deepen non-standard solutions to successfully initiate and realize “break-through innovations”. A creation of a principally new optimized organization structure is a key to success in a progressive development path, where balanced staffing serves as one of its invariants.

Keywords: *MBTI model, acmeological-invariant control, invariant, breakthrough innovations, functional-structural approach*

1. INTRODUCTION

Modern economic reality creates an objective necessity in the trend reconsideration of future possibilities' development so that subjects of economic activity can realize their needs and

interests in economic development. It is due to the fact that current quality transformation of the society requires initiation and implementation of break-through recommendations. This requirement is reinforced by the number of conditions such as globalization; uneven level of economic development of different countries; increasing complexity of the nature, structure and forms of economic activity and competitive relations. Ukrainian economy nowadays requires the model of “possibilities”, “chances”, “break-through”. This model will be built on the steep innovation activity increase in order to timely create further possibilities for economic growth, so that innovation technical basis and new technological way of production will stimulate economic transition to the higher level of its efficiency. The keys to success of this model are highly qualified labor forces, state and international investments to the priority areas of national economy, technology innovations, effective infrastructure, as well as production and sales methods integrated into global market system. In order to launch the break-through model outlined above, the following investment invariants are required: 1) into education along entire life path of the population to enable leading economic growth rate of 10% GDP; 2) into healthcare and sports activities development that will serve as human resources potential support and development and create the growth rate of 8% GDP; 3) into science, social-cultural and other areas of value stream creation such as ideas and technologies that will serve as break-through elements to contribute to 5% of GDP growth rate. However, it is obvious that investments into the above mentioned areas are realized in the size that is significantly lower than required to correspond to society interests. One of the effective instruments to enable synergy break-through is the right combination between such invariants as psychological traits of employees with specific job requirements on one hand and between employees’ psychological characteristics within an organization structure on the other. An effective tool that can help with this task is MBTI model (Mayers Briggs Type Indicator). The implementation of this model enables the increase of Organization management efficiency through organization restructuring or system optimization, in order to increase economic results and decrease micro-level losses. Based on the above we formulate the goal of this study: to prove the most efficient organization structure that will enable break-through technologies implementation in the enterprise.

2. LITERATURE REVIEW

“Break-through innovations” are innovations that open new technology cycle or new innovation business cycle, as their goal is not in existing and established base technology’s development and improvement, but in the complete technology change and market redirection. The model of “Break-through innovations” was created by Clayton Christensen [1], which he introduced in 1997 for the first time in his book “The Innovator's Dilemma: When New Technologies Cause Great Firms to Fail” [2]. This model can be used to describe new technologies’ influence on companies’ functioning. Clayton Christensen engaged himself in the study of the reasons why the biggest world leading companies were rapidly losing their dominating positions when new technologies entered the market. J. Schumpeter was the first one who concluded this correlation, concluding that radical innovations were accompanied by creative destruction transformation process [3]. R. Foster and S. Kaplan demonstrated on the examples of Johnson & Johnson and General Electric that in order to maintain their competitiveness and remain dominant for a long time, modern companies need to master the strategy of discrete evolution and the processes of creative destruction [4]. Lindy Ryan proves that in order for new companies to create their own market, it is required to implement progressive changes through creative destruction as a self-destruction strategy [5]. The empirical studies on companies’ productivity in 24 countries conducted by M. Arthur and Jr. Diamond prove the same idea – that creative destruction is extremely important for companies’ productivity improvement [6]. Further possibilities of break-through technologies introduction with the help of an enterprise’s

available resources and implemented ERP-systems were reflected in research of Hanushchak–Efimenko L., Shcherbak V., Kaplun V. [7]. The process of a creative destruction is often studied from the productivity increase point of view that means the use of the key resource – human capital. For an effective implementation of this resource it is required to involve modern HR-technologies, which apart from an administrative function will include employees' psychological characteristics consideration for certain tasks performance and interaction within the team. Different typology of team roles exist. Team role is a description of the behavior model that influences team members' interaction for a joint goal achievement [8]. Thus, in a project management, a classification of team roles, suggested by Allan J. and Lawless N. is the most widely accepted, also known as the typology of MTR–i [8]. Furthermore, in psychological science, different personality typology approaches exist. The most common are of C.G. Jung and his predecessors. For corporate management goals, the most useful is the model offered by Myers-Briggs [9]. It is important to note, that individual roles in the project team often do not coincide with his/her inborn psychological characteristics. Work experience and gained qualification influence individual behavior within a team, while a psychological type according to Myers-Briggs typology reflects psychological specifics of a person and is less dependent from the external circumstances and experience, but more from inborn qualities of a nervous system. It is therefore to conclude that the application of unique individual creative characteristics identified with the help of MBTI model will enable break-through innovations implementation [10].

3. METHODOLOGY OF MBTI MODEL APPLICATION FOR THE ACMEOLOGICAL-INVARIANT ORGANIZATION MANAGEMENT AS AN INSTRUMENT FOR “BREAK-THROUGH” INNOVATIONS IMPLEMENTATION

“Break-through” in Economics means significant progress in those its foundations that create several original institutional basis (institutions): education (human capital), science, high-technology production (intellectual property), investments and social values. Development level of institutions mentioned above and their quality composition determine the possibility of a break-through in Economics. Furthermore, it is only possible in case of a leading economic development, where the model's substantial form is an Economics of Innovations. Therefore, a country's transition to the new long-term wave of economic growth (that consists of 5, 6 and 7 technology patterns) is only possible under Economics of Innovations conditions, which target itself at the development of high-technology sectors. The authors of the methodology have empirically come to the method of a structural function description. This method is described in the literature as a functional-structural approach (FSA) that is a methodological basis of an explication and analysis of the organization-functional structure of an enterprise and the logic of tasks distribution based on their psychological characteristics with the help of MBTI model. Key foundations of FSA in a short form can be expressed in the following: company's tasks including existing processes and development patterns come as the first priority; company's functions (its subsystems and elements) have regulatory nature and end-to-end functional approach to its analysis and synthesis; functional designation of an organizational unit's is primary in relation to the company's structure; any function reports to the existence purpose and mission of the company; an interaction between company's function and structure in the development process is characterized by their controversial coherence; their consistency and correspondence is temporary and has a cycle nature.

Phase 1: Functional structure should be separated from the existing organization structure. In this case the objects' hierarchy is extracted from divisions' goals, and operations from a functional subdivision. The function's structure might be represented in the form of either a

two-dimensional matrix (table), or a system matrix (for every level of the hierarchy). Matrix field represents an elementary function.

Phase 2: A functions' classification is realized based on the matrix in order to integrate it into ERP-systems and to control its sustainability. At the same time, the provided approach simplifies the design of an organization structure at an enterprise: a target function of the highest subdivision is formulated, whereas cycle performance's elements are created based on existing classifications or via decomposition.

Phase 3 includes analysis of the existing functional performance division. Variability in personal interests according to R. Hogan, R. Blake [11], G. Staggs, L. Larson, F. Borgen [12], is related to the differences in individual characteristics. At the same time, temperament's intensity and professional competencies (TCI) suit especially well for roles differentiation within a project team or an organization, since they measure adaptive functioning better than other modern cadasters [13].

The difference of TCI model vs MBTI is that it measures seven parameters of adaptive functioning, each of which relates to the functioning and adaptivity as managers and/or employees in such critical roles as decision-making, interpersonal relationships and emotional intelligence [14]. These traits include three aspects of one's character (intellectual agility, including self-direction, ability to cooperate and self-improvement), as well as four aspects of one's temperament (reaction to emotional stimulus, including harm avoidance, openness to new experience, dependency from appreciation and stability). TCI model should be used to create teams/organization for already set-up processes within stable functioning companies. In order to introduce "break-through" innovations a team structure should correspond to certain demands regarding creativity, innovative thinking and ability to work with information in order to implement brave plans. Therefore, MBTI model is more suitable for these purposes. Under this criterion, sixteen psychotypes can be divided into four groups of subtypes: EN, IN, ES, IS. It is also important to allocate subtypes that describe the relationship of leadership and subordination, as the project team always has a certain hierarchy: TE, SI, NE, FI. It is believed that the combination in the following psychological types' constructs is a prerequisite for the fruitful introduction of "breakthrough technologies": N – Intuition and E – extraversion [15]. That is, for a psychological characteristics combination «EN – Brainstormer», generally, the form of conducting is an extraversion process [16]. Sensor and intuition for this subtype (EN) is usually balanced, since EN lives in the world of abstract reasoning; nothing is dogma to him/her; in its reality everything is interconnected and everything is possible; he easily connects facts widely known, however, the interconnection between which is not obvious to others [16]. Let's consider the interaction of project team members with different psycho-types during problem-solving by brainstorming. At the first stage in the process of collective discussion, the following psycho-types must take part ENTP, ENFP, ENTJ, ENFJ, INTJ, ESTJ, ESTP (Table 1). They put forward ideas and discuss them. Psycho-types ESFP and ESFJ it is advisable to engage in a discussion to bring a creative atmosphere. Psycho-types INTP, INFP, INFJ can put forward ideas, but collective discussion can be an obstacle for them. For these psychotypes, individual, written brainstorming, brainstorming using e-mail, etc. are more appropriate. Psycho-types ESTJ, ESTP rarely put forward their own ideas, but they can pick up and develop the ideas of other project team members. Ideas, which were subsequently selected for implementation, put forward, most often, psychotypes ENTP, ENFP, ENTJ, ENFJ, INTP, INFP, INTJ, INFJ. In case of an individual brainstorming, written, using e-mail it is useful to involve only the data of the indicated above team members.

Table 1: The optimal role of project team members based on psychotypes in the process of finding breakthrough solutions

The role of team members Psychotype	Communicator	Generator	Critic	Solver	Scheduler	Organizer	Moderator	Finisher
ENTP	+	+	+	+		+		
ENFP	+	+				+		+
ENTJ	+	+	+	+	+	+	+	
ENFJ	+	+				+		
INTP		+	+	+				
INFP		+						
INTJ	+	+	+	+		+		
INFJ		+						
ESFP	+					+		
ESFJ	+					+		
ISTJ								+
ISFJ								+
ISTP			+	+				+
ISFP			+	+				
ESTJ	+		+	+	+	+	+	+
ESTP	+				+	+	+	

In the process of selecting ideas the participation of the following psychotypes is appropriate ENTP, ENTJ, INTP, INTJ, ISTP, ISFP, ESTJ. Naturally, the team members who took part in putting forward ideas should not participate in their selection. However, exceptions to this rule are possible with a team of four or less members. It should be noted that with a small number of members of the project team there is a certain hierarchy of how team members should be used. So the extravert types of ENTP, ENTJ, are better off in putting forward ideas, and introverts INTP, INTJ should lead the selection of ideas. After the previous stage of selecting ideas it is advisable to involve members of the ISTJ and ISFJ types, who can thoroughly analyze the shortcomings of ideas and obstacles on the way of their implementation. In addition ISTJ are good candidates for the preparation and fixation of the results of brainstorming. The best moderators of the discussion are the psychotypes ENTJ, ESTJ, ESTP. In a team of several people, it is expedient to assign an ESTP as a moderator, while ENTJ and ESTJ can perform other roles. ENTJ can take part in putting forward ideas, and ESTJ - in their selection.

Phase 4 covers mathematical reasoning of the model of organization structure optimization. The mathematical justification for the sequence of using the MBTI model to optimize the organizational structure was carried out with the help of the economic and mathematical apparatus of cluster analysis for the JSC “Pharmaceutical Company Darnitsa”. This company recently successfully implemented 2 breakthrough projects. At the end of 2014, the company launched an innovative production of infusion solutions and implemented the ERP system. To generate these breakthrough innovations, it was necessary to optimize the staffing of the performers who were pre-tested with the MBTI psychotype tests. For the hierarchical agglomeration clusterization, the Ward coupling method and the Half Square Euclidean distance were used as a measure of similarity for members of the project team (18 people), who have similar estimates of MBTI psychotypes. Representatives of each cluster are assessed as the average value inside the cluster, as shown in Fig.1.

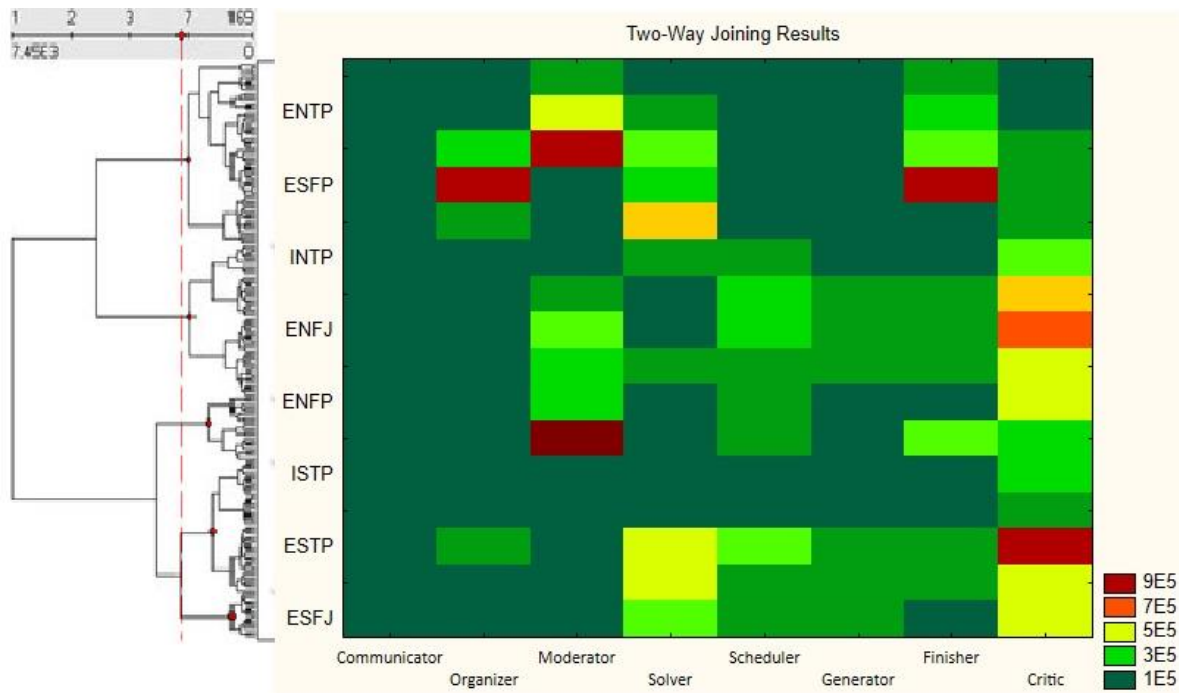

Figure 1: Identification of MBTI cluster psychotypes for optimal roles in the project team

In Fig. 2, clusters 1-5 are arranged in a sequence top-down (from cluster 1 to cluster 5). The optimal number of 5 clusters was calculated using the Davis-Buldin index [17]. The degree of an overlap between the two clusters was estimated by calculating the double probable intersection between them based on the hypergeometric distribution:

$$PI_{hyp}(P_i, G_j) = 1 - \sum_{q=0}^{p-1} \binom{h}{q} \binom{g-h}{n-q} / \binom{g}{n} \quad \begin{matrix} h = |P_j| \\ n = |G_j| \\ p = P_j \cup G_j \end{matrix}$$

where p observations belong to the set P_i of size h, and also belong to the set G_j of size n; and g is a total number of observations. Consequently, the lower the PI_{hyp} is, the higher is the degree of overlap. Here, the p-value of the hypergeometric test is used as a measure of aptitude / ability to perform a role in a team. The distribution of MBTI ratings across the sample is shown in Table 2. On average, members of the project team were exceptionally extreme, being very high in the sustainability of goals achieving. However, there is a significant variability around these mean values, which was considered by cluster analysis.

Table 2: Estimates of the roles of team members according to the MBTI psychotypes

Type of team activity	Descriptive factor	Percentage average	Evaluation meaning	Standard deviation of estimation
Generator	Low Medium (Optimistic)	38,6	-0,29	1,20
Communicator	Low Medium (Organized)	46,0	-0,10	1,20
Critic	Low (Separated)	21,2	-0,80	1,00
Solver	Very high (confident)	88,5	+1,20	1,00
Scheduler	High average (responsible)	65,5	+0,40	0,97
Organizer	High average (useful)	59,9	+0,25	1,20
Moderator	High Medium (Altruistic)	55,2	+0,13	0,99
Finisher	High average (stubborn)	47,2	+0,11	0,88

Clusters of team members who have similar profiles of MBTI psychotypes have been identified using the Ward clustering method without taking into account the current role in the project. The dimensions of the MBTI psychotypes were recorded from low to high, ranging from the mean value of the Likert scale for each sign, as shown by the color coding in Figure 2 for the convenience of visual inspection and pattern recognition. The optimal number of identified clusters of personality was five in accordance to the Davis-Budin index of validity (Fig. 2). Each of these five clusters were characterized by a separate personal profile.

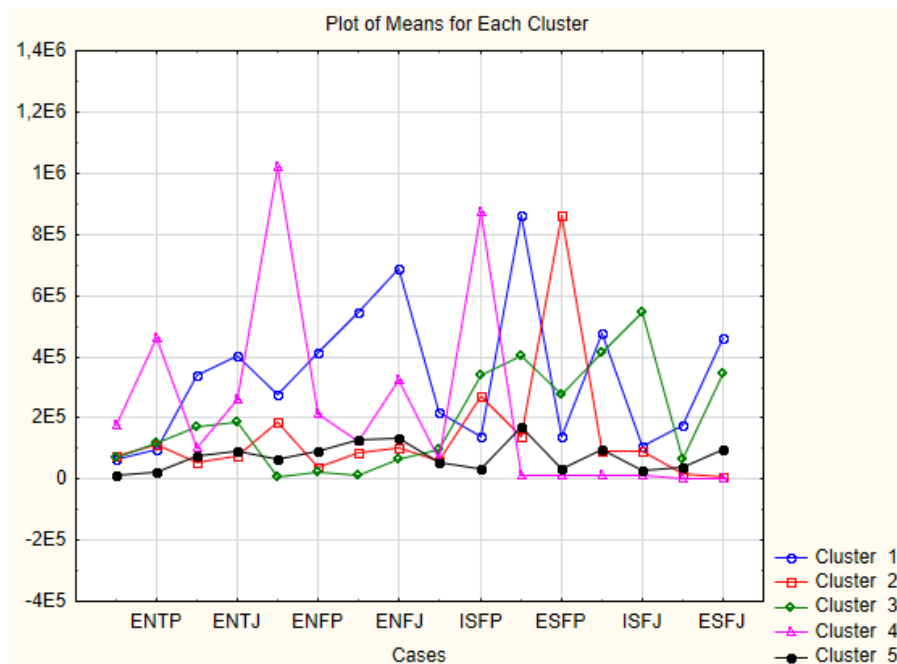

Figure 2: Profile of MBTI psychotypes' clusters average values matched with the current roles in the project.

As a next step, five personal clusters were validated for the relevance of the role in the project and the personal psychotype. Cluster 1 ("investigator") is inherent in the design function "Collective Discussion", 22% (4/18) of the team members correspond to this cluster. The profile of people in this cluster are goal-oriented, highly collegial and skeptical, which allows them effectively solve organizational and planning problems. Cluster 2 ("commander") is inherent in the design function "Criticism, selection of solutions", 28% (5/18) of respondents correspond to this cluster with high indicators of "independence", autonomy, self-direction, low level of shyness/self-criticism. Cluster 3 ("reliable") is inherent in the design function "Moderator," 17% (3/18) of respondents, they have a character of trust, they are persistent, controlling, but friendly and encouraging. Cluster 4 ("breakthrough"), inherent in the design function "Promoting ideas", 11% (2/18) of respondents. They are persistent, ambitious, resourceful. People of this cluster are impulsive with low responsibility and high level of search for innovations. Cluster 5 ("prosecutors") is 22% (4/18) of respondents. The respondents of this cluster have a friendly temperament, responsible, detail-oriented, persistent and hard-working. In analyzing the estimates of the received clusters and their relationship with the psychotypes, a correlation was found, that is typical for the general situation of the need to form an organizational structure for the development of breakthrough innovations (Fig. 3). The choice of the optimal organization structure was made using the toolkit ANOVA. The calculations have shown that the clusters were moderately correlated ($p < 0.01$) with self-direction to find breakthrough innovations ($r = 0.62$), the stability of the new organizational structure ($r = 0.38$),

and the reduction of the risks of non-implementation of the project ($r = -0,27$), but significantly correlated with co-operative ($r = 0.18$) and dependence on remuneration ($r = 0.16$)

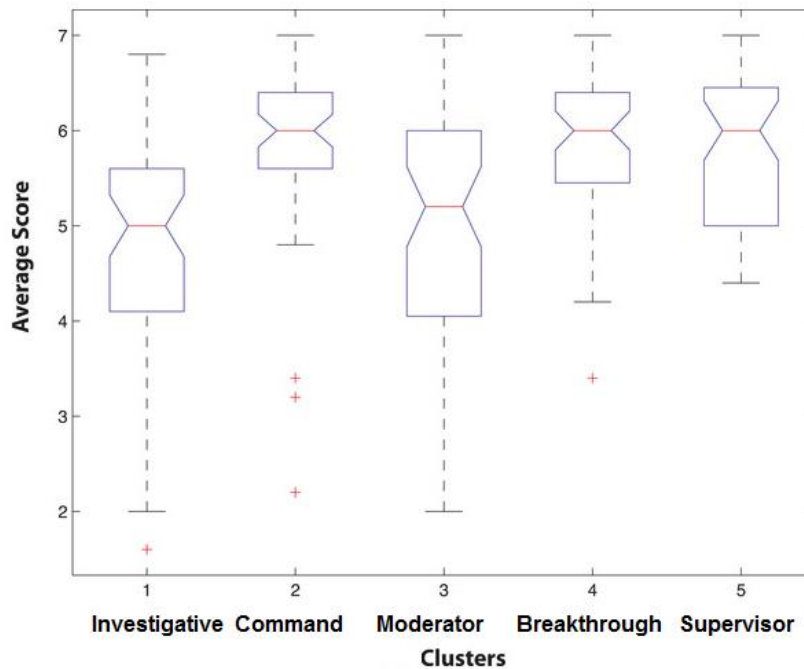

Figure 3: Graphs of mean value distribution of the project goal achievement, depending on project's roles correspondence.

The research has shown that the success of the implementation of a breakthrough innovation project depends on the qualitative and quantitative composition of the project team and their personal profile. The level of satisfaction from the team role may be conditioned by minor differences in personality characteristics that were not fully captured by the five aggregated cluster profiles.

4. CONCLUSIONS

The conducted research explored the methodology of MBTI model as a tool to identify psychological types based on which an optimal design of an acmeological-invariant organization management will be justified, in order to introduce “break-through” innovations to an enterprise. The initiation and successful project realization directly depends on an optimally balanced project team, whose selection should be done depending on their identified psychological characteristics and roles' functional composition. Apart from that, research has shown that one psychological trait is heterogeneous to all members of the studied project team. This trait can be described as a high functionality that helps people to easily adapt and be flexible. This is proved by their significant level of self-direction, cooperation, persistence and overall high level of life satisfaction. Moreover, this trait was often identified among people occupying one positions more than others.

LITERATURE:

1. Dyer, J., Gregersen, H. & Christensen C. (2011). *The Innovator's DNA: Mastering the Five Skills of Disruptive Innovators*. Boston, MA: Harvard Business Press.
2. Christensen, C. (1997). *The innovator's dilemma: when new technologies cause great firms to fail*, Boston, Massachusetts, USA: Harvard Business School Press.
3. Schumpeter, J. (1989). *Essays: on entrepreneurs, innovations, business cycles, and the evolution of capitalism*. Paris: Transactions Publishers. 380 p.

4. Foster, R. & Kaplan, S. (2001). *Creative Destruction: Why Companies That Are Built to Last Underperform the Market and How to Successfully Transform Them*, New York, NY: Currency/Doubleday.
5. Ryan, L. (2013). Leading change through creative destruction: how Netflix's self-destruction strategy created its own market. *International Journal of Business Innovation and Research (IJBIR)*, Vol. 7, No. 4. <https://doi.org/10.1504/ijbir.2013.054868>.
6. Arthur, M. & Diamond, Jr. (2007). Schumpeter's Creative Destruction: A Review of the Evidence. *Econ Journal Watch*, 4(3). 15 p.
7. Hanushchak-Efimenko, L., Shcherbak, V. & Kaplun, V. (2017). Resource-innovative model of raising university autonomy. *Scientific bulletin of Polissia*, 1(9), P. 2. pp. 61–69. DOI: 10.25140/2410-9576-2017-2-1(9)-61-69.
8. Allan, J. & Lawless, N. (2005). Learning through online collaboration by SME staff a scoping investigation into likely team-role stressors. *Education + Training*, 47 (8/9). pp. 653–664. <https://doi.org/10.1108/00400910510633189>.
9. Briggs Myers, I. (1962). *The Myers-Briggs Type Indicator: Manual*. <https://doi.org/10.1037/14404-000>.
10. Myers-Briggs, I., McCaulley, M. & Quenk, N. (1998). *MBTI Manual (A guide to the development and use of the Myers Briggs type indicator)*. Consulting Psychologists Press, 131 p. <https://doi.org/10.1037/t01943-000>.
11. Robert Hogan, Rex Blake. (1999). John Holland's Vocational Typology and Personality Theory. *Journal of Vocational Behavior*. Volume 55, Issue 1, pp. 41–56. <https://doi.org/10.1006/jvbe.1999.1696>.
12. Gena D. Staggs, Lisa M. Larson, Fred H. Borgen (2007). Convergence of Personality and Interests: Meta-Analysis of the Multidimensional Personality Questionnaire and the Strong Interest Inventory. Volume: 15 issue: 4, pp. 423–445. <https://doi.org/10.1177/1069072707305760>
13. Richard A. Grucza & Lewis R. Goldberg (2007). The Comparative Validity of 11 Modern Personality Inventories: Predictions of Behavioral Acts, Informant Reports, and Clinical Indicators. *Journal of Personality Assessment*. Volume 89, Issue 2. pp. 167–187. <https://doi.org/10.1080/00223890701468568>.
14. Keirse, D. & Bates, M. (1978). *Please Understand Me. Character and Temperament Types*. Del Mar, CA: Prometheus Nemesis Book Co.
15. Walter, J. (2003). Neurolinguistic programming: temperament and character types. *BMJ* volume 326 issue 7394. pp. 132–133. <https://doi.org/10.1136/bmj.326.7394.s133a>.
16. Sievert M, Zwir I, Cloninger KM, Lester N, Rozsa S, Cloninger CR. (2016) The influence of temperament and character profiles on specialty choice and well-being in medical residents. *PeerJ* 4:e2319 <https://doi.org/10.7717/peerj.2319>
17. Igor Zwir Henry Huang Eduardo A. Groisman (2005). Analysis of differentially-regulated genes within a regulatory network by GPS genome navigation. *Bioinformatics*, Volume 21, Issue 22, pp. 4073–4083. <https://doi.org/10.1093/bioinformatics/bti672>.

SUSTAINABLE DEVELOPMENT OF MUNICIPALITIES AND SMART CITIES CONCEPT IN THE CZECH REPUBLIC

Veronika Humlerova

*The Institute of Technology and Business in České Budějovice, Faculty of Corporate Strategy,
Department of Marketing and Tourism, Czech Republic
veronika.humlerova@seznam.cz*

Petra Partlova

*The Institute of Technology and Business in České Budějovice, Faculty of Corporate Strategy,
Department of Management, Czech Republic
vachalova.p@seznam.cz*

ABSTRACT

Rising urbanization is a challenge for sustainable urban development. The UN predicts 70% of urban population by 2050, 80% of global emissions, 75% of energy consumption. Sustainable development can not be achieved without significant change in the way we build and manage our urban areas. Against the background of economic and technological changes caused by the globalization and the integration process, cities in Europe face the challenge of combining competitiveness and sustainable urban development simultaneously. Very evidently, this challenge is likely to have an impact on issues of urban quality droughts and housing, economy, culture, social and environmental conditions. This paper focuses on smart cities concept in the Czech Republic, the transformation, examples and possibilities of economic support.

Keywords: *Human Capital, Local Agenda 21, Smart Cities, Sustainable Development*

1. INTRODUCTION

Local Agenda 21 is a tool for implementing sustainable development at local and regional level and a process that improves the quality of life in all its aspects by improving governance, strategic planning and governance and engaging the public. Agenda 21 was adopted at the UN Summit in Rio de Janeiro in 1992. It is a global strategic and action plan for the world community that sets out concrete steps towards sustainable development. It is precisely this document that contains a definition of what is particularly important in Local Agenda 21 (Tuxworth, 2007). Local Agenda 21 (LA21) fits into a broader stream of good governance, which is included under the concept of good governance and good governance. Good governance, must be (viewed from the UN and the EU) is open, transparent and accountable to the public, effectively allowing public participation in decision-making and planning based on working in partnership with other social sectors, and respecting the professional point of view. Only such public administration can lead to the long-term sustainable development of the municipality or region. And MA21 is the process where sustainable development is the primary goal. An essential part of the functioning MA21 is good strategic planning and management, including a financing system; ongoing and active communication with the public - building partnerships; systematic and measurable routing to sustainable development (Echebarria, 2016). The Smart City concept has emerged as part of the SET-Plan, published in 2007. The SET Plan is about to address issues related to the future of energy. Smart Cities also feature. The European Commission Communication of 2012 defines and defines the European Innovation Partnership on Smart Cities and Communities. The brief purpose of the initiatives is to accelerate the transformation of European cities into Intelligent Cities (including description of problem areas, outline of measures and priorities and implementation) (Kitchin, 2014). The Smart Cities concept is also relevant from the point of view of the EU Strategic Document - Europe 2020 Strategy.

In general, it provides support for virtually all sectoral policies that can be promoted within the Smart Cities concept. The key underlying of the Europe 2020 Strategy is to support economies that are economical and environmentally friendly with the maximum possible use of R & D & I and low-carbon technologies. This is also the case for partial targets (even quantified) and measures. The strategy is also a top document for cohesion policy, so this approach by the EC should also appear in the Member States' documents. The Smart city is one of the concepts of applying sustainable development principles to a city organization that relies on the use of modern technologies to improve the quality of life and make governance more effective. This concept is most widely used in the field of energy and transport, which can be tackled more effectively by deploying appropriate information and communication technologies (ICT). The Smart City concept, however, does not only cover the two areas mentioned above, but can also be applied to others such as water management, waste management, e-government, and crisis management. At the same time, emphasis is placed on "hard" and "soft" aspects of managing city life (Allwinkle, 2011; Caragliu, 2011). The Smart City concept is a program change led by the political representation of the city, and it is a gradual process not a state. Compared to regular planning and operation of urban agendas, Smart City brings simplification of the process of involving professionals and the general public through electronic tools (such as communication platforms or social networks). (Guerrero-Pérez, 2013) It provides the opportunity for city strategies not only to be formed by a competent supplier in cooperation with a given city department, but by working groups composed of experts from different institutions, local entrepreneurs and interest clubs that effectively coordinate the city using electronic media. The resulting strategies can then be put forward to comments on electronic public forums and then discussed with the public at open meetings so that the introduction of their final form is generally accepted by citizens, while at the same time reflecting on the maximum ideas and ideas. Such a process also anticipates prudent investment in new technologies to support these new programs, which has an impact on investment but above all on operating costs associated with technologies (Shapiro, 2006).

2. MATERIALS AND METHODS

This paper focuses on sustainable development of municipalities and cities through the smart cities concept in the Czech Republic, the transformation, examples and possibilities of economic support. For our work we have chosen the methodology of smart cities from Vienna University of Technology. (Smart cities are defined by six characteristics. Each characteristic is filled with a number of indicators. In total, 31 factors were finally selected to define these six characteristics. Smart economy includes factors that affect the economic competitiveness of the analyzed city such as innovation, business, trade marks, productivity and labor market flexibility, as well as integration in the (national) market. Smart People includes a set of indicators that analyze the level of qualifications or education of citizens, but also the quality of social interactions in the area of integration, especially in the areas of public life. Intelligent governance includes aspects of political behavior in the analyzed city, the structure of services offered to citizens, and the functioning of governance. Smart mobility includes aspects such as availability of information and communication technologies and the modernization and sustainability of transport systems. An intelligent environment describes attractive natural conditions (climate, greenery, etc.), pollution, resource management, and environmental efforts. Finally, Smart Living includes different aspects of quality of life such as culture, health, safety, housing, tourism etc. (European Smart Cities, 2015b). Economic support will be shown at Operational Programme Environment from the European Union in the Programming Period 2014-2020. Through this operational program, it is possible for making the cities and municipalities smarter, use the two priority axes namely PO 2 Improvement of air quality in human settlements and PO 5 Energy savings.

The aim of the article is to map the drawing on these two priority axes by the municipalities and regions of the Czech Republic. For clarity, the capital city of Prague and its city districts were removed from the analysis.

3. RESULTS

3.1. Smart Cities Transformation

The well-known definition of smart city based on the six policy axes: smart environment, mobility, citizenship, living, government and economy. Environment covers promotion of energy saving, the use of renewable energy, and reduction of environmental pollution, in particular CO² emissions. Mobility comprise accessible and safe transport, creation of an integrated mobility system with low environmental impact. Citizenship includes promotion of life-long learning and education, nurturing of cultural diversity, promotion of civic engagement and citizens' creativity. Smart living covers safeguarding individual and public health; implementation of welfare, cultural, and tourist policies, promotion of social cohesion. Government and political participation based on promotion of political participation, adoption of transparent decision-making; creation of accessible online services. In addition, economy covers services supporting local SMEs and innovation ecosystems, targeting women and young people in particular.

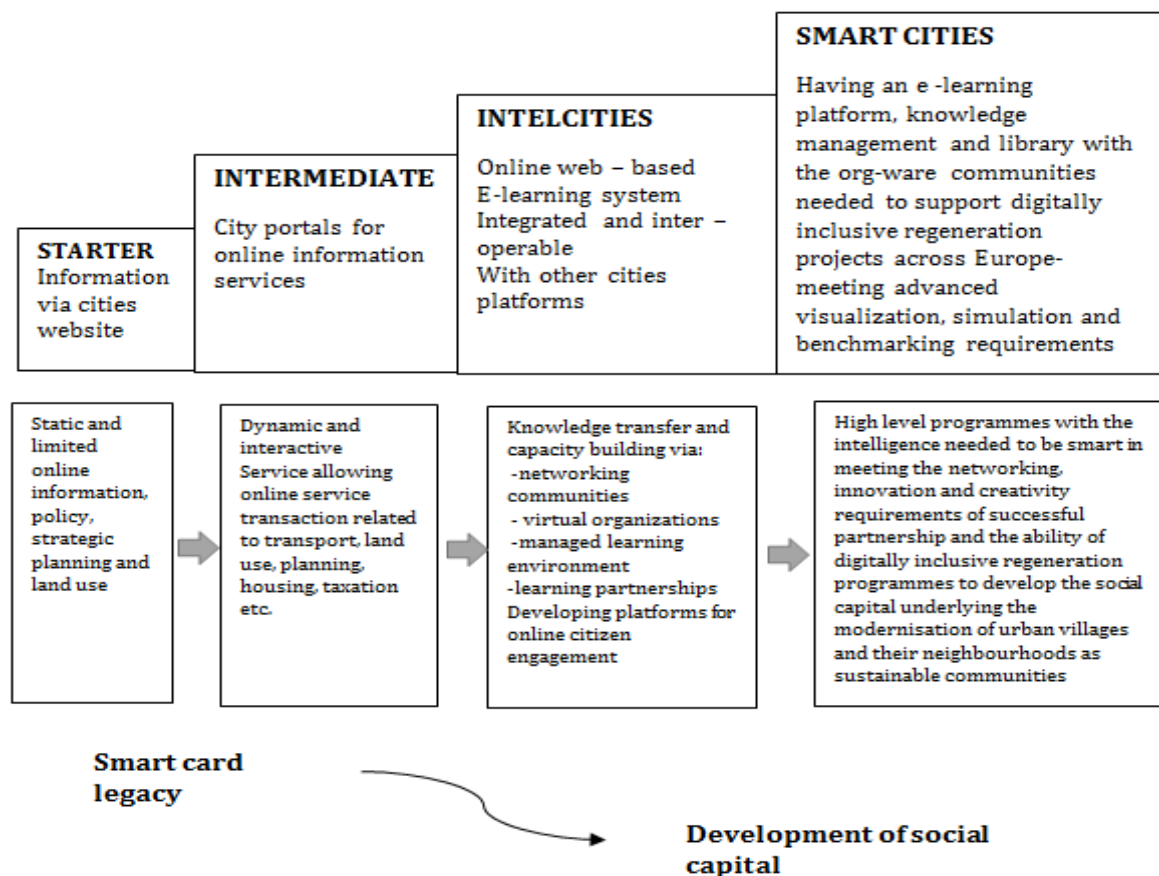

Figure 1: Making the city SMART(er) (authors)

As the figure 1 shows, the process of transforming the city into a smart city has been augmented and turned into e-learning platforms, supported by knowledge management systems and digital libraries for developing ICT-enabled networks.

ICT-enabled networks with the innovative and creative partnerships needed to develop the social capital required for cities to be smart(er) in engaging citizens and empowering communities as key constituents of digitally inclusive regeneration programmes. Smart cities ought to focus on the humans capital side of the equation and: “create a real shift in the balance of power between the use of information technology by business, government, communities and ordinary people who live in cities”. Following are two figures (picture 2 and picture 3) that track the results achieved for two groups of analyzed cities. The first group of cities is Cities from 100 000 to 500 000 inhabitants, in the Czech Republic the cities of Plzeň and Ústí nad Labem were monitored. The second group is Cities from 300 000 to 1 million inhabitants. For the purpose of research, the cities of Brno and Ostrava were selected from the Czech Republic.

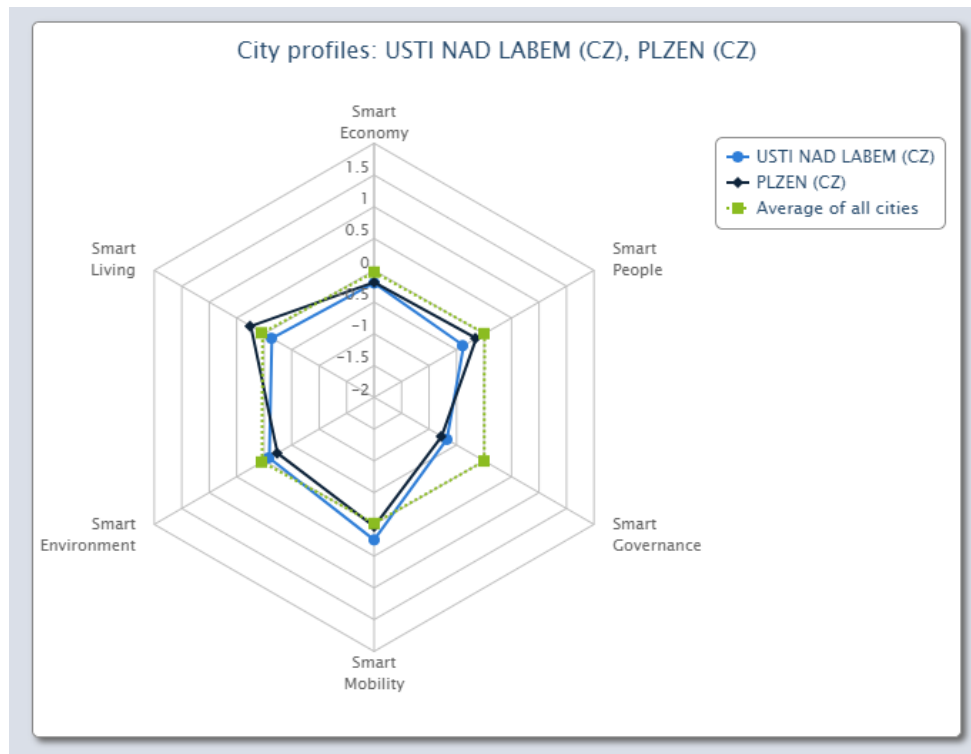

Figure 2: Benchmarking of Selected Smart Cities in Czech Republic in the year 2014 (European Smart Cities, 2014)

As can be seen from the Plzeň chart, it has the highest results in the smart government characteristic. Of the three monitored indicators, the highest result of Pilsen was acquired by a transport government and participation in the public life of the city. Another above-average result is the indicators evaluated in the smart environment and above all the monitored indicators environmental environment and public awareness of the quality of the environment. Ústí nad Labem, it had somewhat worse results than Pilsen, noting the better achieved results in the characteristic of smart living, in the monitored indicators of cultural facilities and touristic attractiveness, where it acquired the city of above-average values. Other values move around the center or worse. Both cities have achieved underperformance in smart mobility. In order to be able to achieve a good position, these cities should focus on identifying their strengths and weaknesses, as well as identifying their chances of positioning and ensuring and extending comparative advantages in certain key resources against other cities of the same level. City rankings are a tool to identify these assets. Although they are quite common in recent times, current rankings are very different in their approaches and methods. Mostly they have quite specific goals focused on shareholder interests. Also, local governments rarely discuss public ranking results, if their own city is not ranked high.

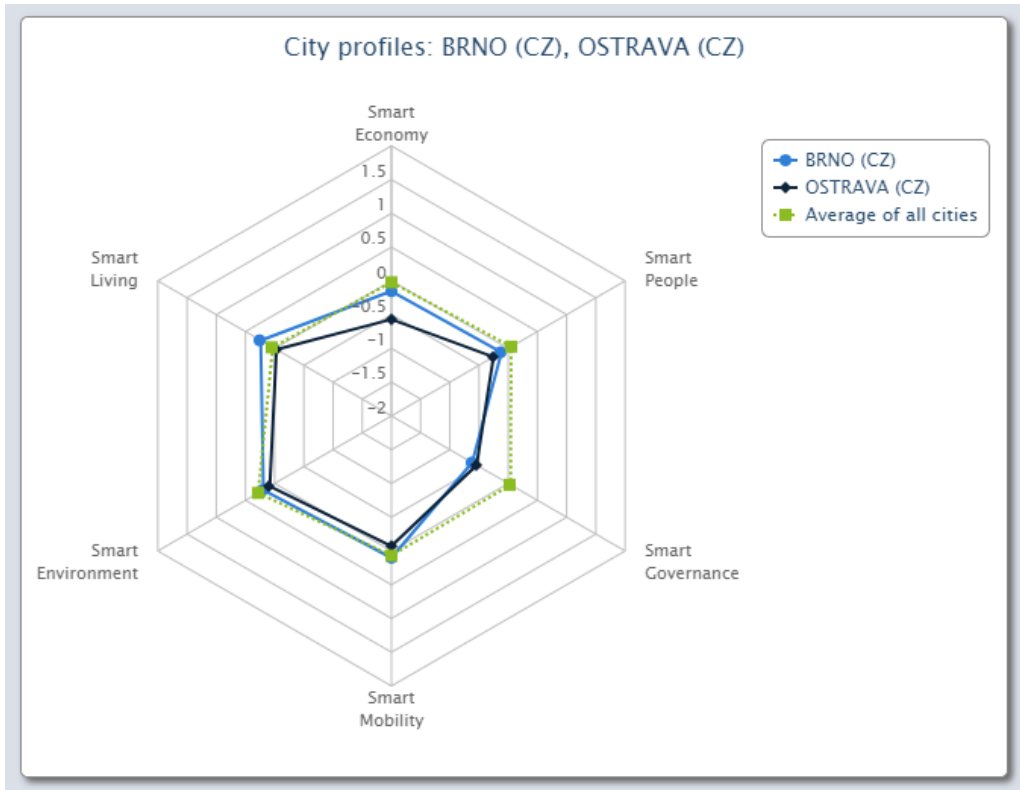
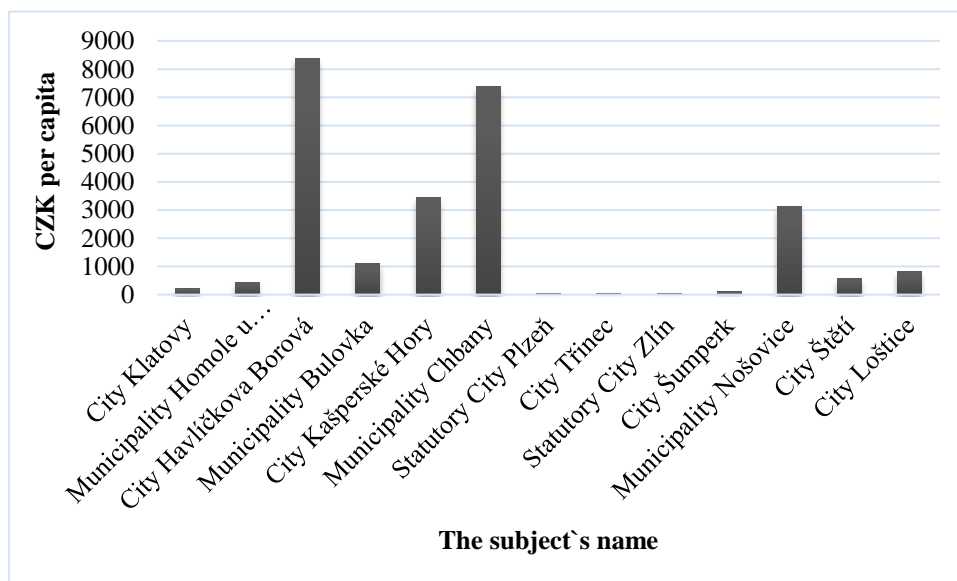

Figure 3: Benchmarking of Selected Smart Cities in Czech Republic in the year 2015 (European Smart Cities, 2015a)

3.2. Promoting the emergence of Smart Cities funded by the European Union

Municipalities and cities can benefit from a variety of European Union financial instruments. This could be, for example, the Environment Operational Program, whose allocation for the 2014-20 period amounts to EUR 2.6 billion. This program makes use of Axis 2 Improving Air Quality in Human Residences and Priority Axis 5 Energy Savings. Priority Axis 2 has not been used by municipalities and cities so far. Graph 1: Funding in legal acts on the granting/transfer of aid (contribution of the European Union)



Graph 1: Funding in legal acts on the granting/transfer of aid (contribution of the European Union) (Source: Ministry of Regional Development, 2018; edited by authors)

Since 2014 it have been supported from the OP Environment, the Priority Axis 2 Improving air quality in human settlements projects, 13 of 15 municipalities, the EU's share amounted to almost 46 million CZK. Graph 1 shows the contributions of the European Union, which the municipalities and cities obtained per capita. On the other hand, priority axis 5 Energy savings was used relatively intensively by cities and municipalities. Since 2014, a total of 654 projects have been supported, totaling CZK 1390 million. Graph 2 illustrates the amounts drawn by individual regions in the Czech Republic. The highest amount (total CZK 128 436 405, CZK 3 293 231 per project) was drawn by the Ústí nad Labem Region, the vast majority of projects were focusing on the thermal insulation of nursery and elementary schools, cultural houses and municipal and municipal authorities.

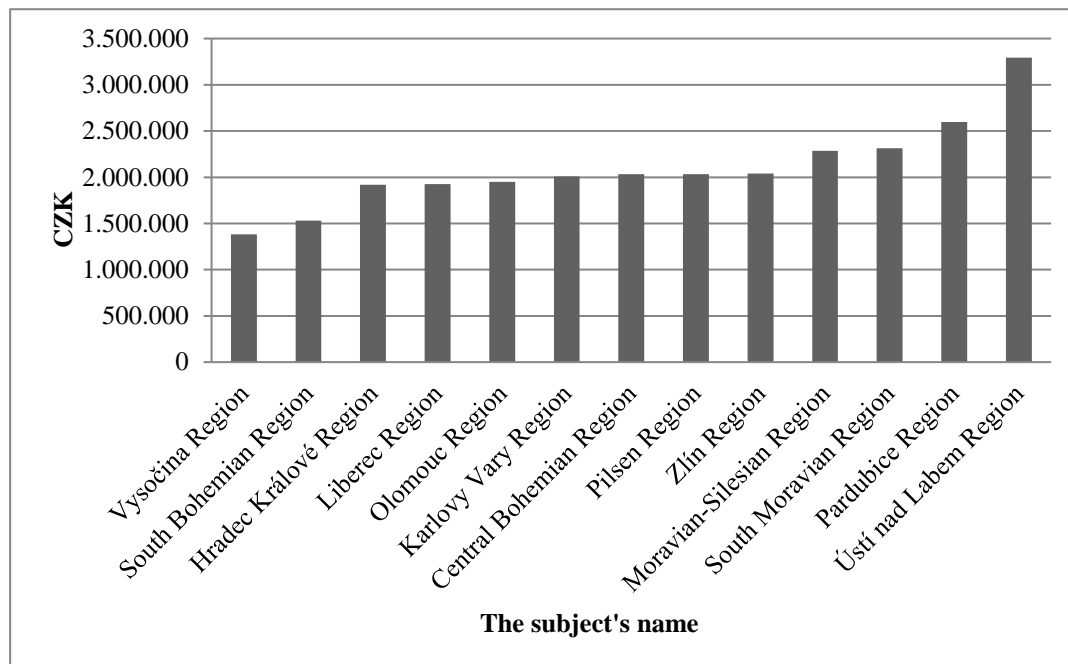

Graph 2: Funding in legal acts on the granting/transfer of aid (contribution of the European Union) per project (Source: Ministry of Regional Development, 2018; edited by authors)

4. CONCLUSION

Currently it has prepared a concept only a limited number of cities. Not only their quality, but also their focus and procedures differ. In most cities, we meet with more emphasis on technology and procedures and functioning of the municipal authorities. There is no focus on social and civic life, and cooperation between municipalities and cities with other entities such as non-profit organizations, business entities. Although the Smart City methodology, for example, has been linked to the Local Agenda 21 and the European Commission level, the European Innovation Partnership has been set up for the purpose of its development and implementation, only a few cities (eg Prague, Brno, Pardubice or Písek). Existing specific concepts have different qualities, they are created by different procedures and are focused on different themes. Most of them are focused on technology and technical spirits of cities and elements of the city's own functioning (ie services to its inhabitants), and social and civic life are at stake. In some cases, there is a noticeable tendency to the given interests of the external processor of the concept. The Czech Republic also lacks a strategic document that summarizes the experience of municipal and urban representatives themselves, links the Smart City concept elements to all types of agendas that municipalities and city authorities are leading, and also includes detailed guides and procedures that would cover all phases of the creation and implementation of a city or municipal Smart City concept.

ACKNOWLEDGEMENT: *This research is part of the project 8110IGS201803 „Analysis of intersectoral links between private, public and non-profit sectors“ by The Institute of Technology and Business in České Budějovice.*

LITERATURE:

1. Allwinkle, S., & Cruickshank, P. (2011). Creating Smart-er Cities: An Overview. *Journal Of Urban Technology*, 18(2), 1-16.
2. Caragliu, A., Del Bo, C., & Nijkamp, P. (2011). Smart Cities in Europe. *Journal Of Urban Technology*, 18(2), 65-82.
3. Echebarria, C., Barrutia, J. M., & Aguado, I. (2016). Local Agenda 21: Progress in Spain. *European Urban And Regional Studies*, 11(3), 273-281.
4. EUROPEAN SMART CITIES (2014). *Benchmarking*. Vienna University of Technology, Austria. Retrieved 12.04.2018 from: <http://www.smart-cities.eu/index.php?cid=5&city=47&ver=3>
5. EUROPEAN SMART CITIES (2015a). *Benchmarking*. Vienna University of Technology, Austria. Retrieved 12.04.2018 from: <http://www.smart-cities.eu/index.php?cid=5&city=47&ver=4>
6. EUROPEAN SMART CITIES (2015b). *The Smart City Model*. Vienna University of Technology, Austria. Retrieved 12.04.2018 from: <http://www.smart-cities.eu/index.php?cid=5&city=47&ver=4>
7. Guerrero-Pérez, A.D. et al (2013). Network Architecture based on Virtualized Networks for Smart Cities. *White Papers from the Smart Cities of the Future Kickoff Event*. Guadalajara, Mexico. Retrieved 12.04.2018 from: https://smartcities.ieee.org/images/files/pdf/ngn_sdn_v3.1.0.pdf
8. Kitchin, R. (2014). The real-time city? Big data and smart urbanism. *Geojournal*, 79(1), 1-14.
9. Ministry of Regional Development (2018). Information about drawing EU funds in the programming period 2014-2020. Retrieved 12.04.2018 from: <http://www.strukturalni-fondy.cz/cs/Informace-o-cerpani/Cerpani-v-obdobi-2014-2020>
10. MITCHELL, W. J. (2007). *Intelligent cities. e-Journal on the Knowledge Society*. Retrieved 12.04.2018 from: <http://www.uoc.edu/uocpapers/5/dt/eng/mitchell.pdf>
11. Shapiro, J. M. (2006). Smart Cities: Quality of Life, Productivity, and the Growth Effects of Human Capital. *Review Of Economics And Statistics*, 88(2), 324-335.
12. Tuxworth, B. (2007). From environment to sustainability: Surveys and analysis of local agenda 21 process development in UK local authorities]. *Local Environment*, 1(3), 277-297.

FORMATION OF THE INVESTMENT POTENTIAL OF THE CONSTRUCTION SECTOR (ON THE EXAMPLE OF UKRAINE)

Shlafman Natalya

*Institute for Market Problems and Economic and Environmental Studies of the National Academy of Sciences of Ukraine, Ukraine
natashl@ukr.net*

Frolina Kateryna

*Odessa State Academy of Civil Engineering and Architecture, Ukraine
kateryna.frolina@gmail.com*

ABSTRACT

The purpose of the article is to develop a methodology for determining the need for the amount of investment resources needed to build the investment potential (IP) of the construction sector in the example of Ukraine. The research methodology is economic and mathematical modeling. The results of the research: to build a model for analysis of the investment potential of the construction sector (IPCS) at the first stage, a selection of formalized factors was made, which were significant from the point of view of its growth, while modeling the IP as the initial characteristic of the model considered the growth rate of capital investments. In the second stage, the three-factor Cobb-Douglas production function was selected for the IPCS study; in the third stage, the necessary statistical information is collected; at the fourth stage - calculations were made, including: a functional dependence was constructed, allowing to analyze the effect of changing the value of one of the selected factors on the resulting factor. Conclusions: the conducted studies showed that market participants, investors can use the proposed methodology to determine the factors that influence the improvement of IPCS, the degree of their influence, the determination of the values necessary to achieve a given level of investment potential. In addition, the results obtained in this study can be used to further justify the priority areas of the state investment policy in the construction sector and to find effective tools for its implementation.

Keywords: *investment potential, construction sector, three-factor production function, method of determining the need*

1. INTRODUCTION

In modern conditions, one of the most demanded by society and the state in its social orientation and investment capacity is the construction sector. However, today, the construction sector, like all of Ukraine as a whole, is experiencing a difficult period: an unstable economic situation, innovations in the legislative framework and an undeveloped mechanism of work under the new rules, the energy crisis and the unwillingness to massive transition of enterprises to energy-saving technologies. The role of investment policy in acquiring capital investments to increase the volume of construction work and increase the investment potential of the construction sector in Ukraine and regions is more regressive than progressive. An important role in ensuring the growth of the socio-economic system through its stabilization and adaptation to the changing external and internal conditions is played by the system of state regulation. At the present stage of development, the construction sector increased multiple synergistic effect of the components proceeding rational process organization and management of construction. In fact, no significant investment and construction project is being implemented today without a collaborative component at the level of management, resource and information interactions, design and construction processes, their documentary, regulatory and technical support. The weak investment activity of the state, enterprises and the population, high intra-industry competition

and the monopoly position of some construction companies, unnecessary administrative barriers, as well as imperfection of technical regulation, imbalance of construction norms and regulations with international standards negatively affect business activity in the construction industry. Thus, there is an objective need to intensify investment activity and improve the methods of regulating investment processes and their compliance with modern needs. In this context, the role of scientific approaches to develop a balanced and relevant to industry features and dynamic environment changes effective mechanisms of state regulation of investment activity in the construction industry by bringing investment, which are among the most important areas of research investment issues. Scientists pay enough attention to the definition of the concept of "investment" and the categories that create the conceptual apparatus of this direction of economic science. Theoretical aspects of investment and issues of state regulation of investment activity have been developed in the writings of such authors as: (Keynes J.M., 1997), (Lisyuk V.M., 2011), (Sharpe W., 2006), (Harrison A., 2002), (Dolan E., 1992), (Masse P., 1971). To modern research, which marked further development of the theory, methodology and practice of investment in various economic activities include works: (European Investment Bank, 2017), (Gogiasvili Salome, 2016), (I. So, A. Staskevicius, 2015), (Layko O.I., 2014), (Van Horn D., Vahovich D., 2008), (Gitman L.J., 2010), (Blank I.A., 2006), (Hoiko A.F., 1999), (Danilov O.D., 2001). However, despite the rather deep processing of many theoretical and methodological issues and practical research on the mechanisms of state regulation of investment in different sectors of economic activity, including the construction industry in the state, many questions remained outside research. In addition, the current economic crisis requires new approaches to solving the problem of intensifying investment activity. Thus, the purpose of the article is to develop a methodology for determining the need for the volume of investment resources necessary to form the investment potential of the construction industry on the example of Ukraine.

2. METHODOLOGY

The investment potential has the capacity to stabilize the construction industry at the macro and micro levels, increase business activity. The research of investment problems is in the sight of many domestic and foreign scholars, but it should be noted that there is a significant difference in the interpretation of key concepts in economic scientific literature and regulatory documents, and there is still no universal definition of them that would satisfy the needs of both theory and practice. Basic and rather controversial in the investment paradigm of the construction sector is the concept of "investment", there are many versions of it. The term "investment" comes from the Latin word "invest" – to invest. (Campbell R. McConnell, Stanley L. Brue, 2013, p.388) characterize investment as "the cost of production and accumulation of means of production and increase of material stocks". On the income that is expected accentuated in determining investment (Sharp W.F., Aleksander G.J., Beyli J.V., 2001, p.17), who believe that the term "investment" should mean a categorical abandonment of the present good for the (possibly) value in the future. (Gitman L.J., 2010) has a less categorical idea about investing. His investment – a way to save capital for the future by placing initial capital in various forms. Some scientists, such as (Merkulov J.S., 2010, p. 15), (Mocherny S.V., 2000, p. 13), (Moroz A.M., 1993, p. 123), (Pokropivny O.F., 1995, p. 245), (Chervanov D.M., Neykova L.I., 1999, p. 130), whose scientific interests are mainly related to investments, in their writings treat investments as long-term investments. They argue that only through long-term capital investment can be achieved business income. It is possible that such views have arisen due to the influence of scientific and official thought from the time of transition to a market economy, when the category of "investment" at the official level was not fully justified and considered, but considered the concept of "capital investment" - exclusively as an expense for the creation of new fixed assets, their expansion, reconstruction and renovation, which "were implemented

in the form of long-term capital investments in various sectors of the economy" (Konoplitsky V., Filina A., 1996, p. 185). Investments are a category of financial markets that can exist and occur only in the process of distributing the inter-object redistribution of funds. Such approaches, in our opinion, reject the possibility of short-term investments (up to one year). The current practice of investing in projects with a short term return on capital in the face of prolonged inflationary processes, high investment risks that are characteristic of Ukraine, is entirely appropriate. In addition, it is not necessary to identify "investments" with "capital investments", because capital investment is one of the forms of investment, because they are considered in the context of this study as means for housing construction. Investments are the same as current assets, intangible assets (patents, licenses), financial instruments, etc. In foreign economic literature, the terms "investment" are emphasized on such an important feature as the ability of the investment process to generate revenue. Thus, the French economist (Masse P., 1971, p. 27) argues that the act of capital investment is an act of exchange to meet today's need for expectations of satisfying it in the future with the help of the invested goods. (Dolan E.J., Lindsey D., 1992, p. 13) define investments as "an increase in the amount of capital that functions in the economic system, that is, an increase in the supply of productive resources." By definition (Blank I.A., 2006, p. 9), "Investment company – investing capital in all its forms in various objects (tools) its business for profit and to achieve economic or non-economic effects, the implementation of which is based on market principles and due to the time factor, risk and liquidity". Therefore, most authors identify the purpose of the investment process, but do not specify the objects of investment and do not determine the nature of investment (financial, material or intellectual). In general, the emphasis on anticipating an increase in capital in the future is predominant in determining investment. In our opinion, in today's business environment, for the realization of its economic goals, it is not enough to focus solely on profit. Long-term development involves a move towards social responsibility, which not only creates a positive image of the company, but also reduces operational risks, expands the market, increases the investment rating. Investing can cause not only economic benefits, but also to the environmental and social impact. In the writings of Western economists, investment studied in the unity of two aspects: resources (capital values) and investments (expenses). The most complete approach is presented in the writings of the Nobel Prize laureate (Keynes J.M., 1997, p. 117). He understood the investment "... the current increase in the value of capital assets as a result of the production activity of this period. "This is – "... the part of the profit for a certain period that was not used for consumption". However, if the funds are not in circulation - it simultaneously reduces their value as a result of inflation, and on a global scale reduces turnover and thus contributes to the crisis. We believe that investing is a process of attracting accumulated capital into circulation in order to generate income or benefit. In addition, it is believed that investment is only an investment of money, which is hard to agree with, since such operations can be carried out not only in monetary terms but also in other forms – various instruments of the stock market, intangible assets, real estate, technologies, etc. However, not always unused funds can be attributed to investment, since money, which is lagging behind and not in circulation, can not bring a positive value of profit and lose its value under the influence of certain factors, the most widespread among which is inflation. Therefore, we consider the appropriated interpretation of investments as a direct process of transformation into the cost of accumulated capital to obtain some useful effect or income. In view of the above-mentioned investments, they should be characterized as investments (financial, material, intellectual), costs that, after some time, will lead to a multiplication of wealth, but income is not considered as a motive of investment activity. Investments – the essence of time derivative of savings; what today accumulates will bring revenue tomorrow, however, the opposite will be true: what brings profit today - in the future it will allow to create capital. Thus, the difference between the two categories is rather conditional, but it will still allow the concept of investments in capital

formation to be equated with the fact that it generates income on invested capital at a given time. The motives for investing and saving various recipients are determined by the sum of factors: economic (inflation, tax policy, monetary policy), political (legislative measures, legal basis of investment, stability of state regulation in general), scientific and technical (level of development of technology, industrial potential), socio-economic, etc.; and also the factors of the micro-environment: availability of investment instruments, level of investment competition in the investment market, resource sufficiency, etc. The definition of investment in the Law of Ukraine "On Investment Activity" as "all types of property and intellectual property that are invested in objects of entrepreneurial and other activities, which result in the creation of profit (income) or achieved social effect" reveals the relationship, the process conversion of investment resources into investments, expenses. Also, the law provided a broad classification of investments and of investment activity. Based on the results of the analysis of definitions, we consider investments as a target, timely investment of financial, material and intellectual resources in the development of their business or other business entity in order to obtain an economic, social or other effect. Our judgments about the essence of investment activity for the construction industry are based on the disclosure of this category as targeted actions aimed at finding, evaluating and selecting potential investment objects, as well as entering into agreements relating to their acquisition or financing and ensuring return on investment from the purpose of forming a safe and comfortable environment of life, providing effective financial and economic, technical indicators of the activity of construction enterprises. In general, the investment system of the construction industry is defined as a complex of interconnected elements of the regulatory legal form, formal and informal norms and rules of organization of the work of subjects and objects of the investment process in the implementation of their investments and in the organization of the production process (reproduction of capital) (Layko O.I., 2014, p. 55). For the study of state regulation of the construction industry it is important to define the definition of "investment potential". According to (Grinyova V.M., Koyda V.O., Lepeiko T.I., Koude O.P., 2008, p. 358), "... investment potential - an opportunity to invest for further its growth or investment opportunities to conduct, support or preserve anything." Under the investment potential (Zubkova V.I., Nakayaylo A.V., Losev S.A., 2001, p. 34) understand "... a set of financial and investment resources of the enterprise, allowing him to carry out an effective investment activity aimed at ensuring its efficient and sustainable business activities." (Pokatayeva K.P., 2007, p. 264) defines the investment potential of the enterprise as an organized set of available economic resources that is in system unity, as well as, due to their current level of development, the possibilities for mobilizing domestic and foreign investment funds to realize the strategic and tactical objectives of the enterprise through the investment mechanism. The investment potential of the country accumulates the investment potentials of all regions, industries and businesses, and the broader their entirety. Between the potentials of different levels as sets is the relation of attachment and intersection. When determining the investment potential at all levels of economic activity, the main macroeconomic, socio-demographic and other characteristics of them are taken into account, it is generalized and acts as a weighted sum of partial potentials, namely: resource, human, raw material, industrial, infrastructure, financial, innovative, consumer, institutional, tourist, ecological, etc. Capital investment in the construction sector contributes to solving the most important issue - providing housing to the population. In general, this issue should be considered not only from the point of view of solving social problems in the state, but also from the point of view of expanding the market of production of many enterprises, first of all affiliated with the construction industry – the production of building materials, furniture, glass, window constructions, home appliances, a set of products for the needs of housing and communal services, etc. That is, the construction industry prompts cooperation and promotes the development of related industries. The construction sector, especially its housing sector, is also able to function during times of

economic crisis, as the demand for housing, along with the involvement in the construction of funds is always there. Construction of housing promotes the development of regions, increases employment, contributes to the fight against unemployment, increases the welfare of the population. In Ukraine, as well as in developed countries, capital investments are largely filled with money from the population, and foreign investments may be desirable to focus on the formation of a large and accessible to all segments of the population rental housing market. For Ukrainian partners of Western investment companies, the rental property market is a guarantee of spare and relatively stable assets for investment in construction. In addition, the construction of rental housing positively affects the behavior of society, its economic development, stimulates the development of other industries. The investment potential of the Ukrainian construction sector is localized today, mainly in the area of residential buildings, as there is demand for these objects among the population, while industrial, social and communal construction work is practically not conducted due to lack of investment. An investor, both foreign and domestic, in the crisis state of the Ukrainian economy, will not risk investing its financial resources on construction, the creation of production facilities, where there is no guarantee of their use and payback. Today, scientists and experts agree that in the near future, while the economic situation in the country is not stabilizing, one should not expect the arrival of investments in those sectors of the construction industry that reduce industrial facilities. The construction of social facilities (kindergartens, hospitals, schools) and communal infrastructure is entirely dependent on the filling of local budgets and the desire of local authorities to create and repair these objects, as well as the state of development of partnership in investment activities between local authorities and entrepreneurship in the construction industry. Currently, foreign investment in the construction sector in Ukraine is insignificant (3% in 2015). Currently, a foreign investor is best placed to invest in Ukrainian real estate, because prices in Ukraine are still lower than in Europe, good attitude of the authorities, and willingness to cooperate with foreign businessmen investing in the Ukrainian economy. Objects for investing in the local authorities a lot, it is ready to provide land plots for the construction of social infrastructure, for example, the shortage of kindergartens in many cities. For Ukraine the construction sector from the standpoint of public interest and investors with profitable revenue perspective is also highlighted local government land for the construction of logistics buildings and industrial buildings. The actions of investors in this direction will stimulate the employment of the population of cities and regions, promote decentralization processes, because they will fill local budgets with taxes and, most importantly, will contribute to the growth of the investment potential of the construction sector as a whole. Consequently, it is necessary to analyze and evaluate the investment potential of the construction industry, especially the industrial construction sector and the construction of infrastructure objects, such as industrial, transport, and social. Investment potential in construction in creating an effective investment strategy provides for the growth of the socio-economic effect and the creation of conditions for the growth of domestic investment resources.

3. THE MODEL

In order to assess the investment potential, it is necessary to substantiate the indicators used to determine the process of capital investment and its developments in the industry, changes in the volume of construction work that was observed not only in the past, but also in terms of future opportunities. To construct a model for analyzing the investment potential of the construction industry in order to make a rational decision, we will initially conduct studies in which we will define a system of formalized factors that will allow local governments to choose the best of the proposed alternatives in terms of regional significance, strategic feasibility and investment effectiveness of the impact on the investment potential of the construction industry. Determining the need for the total amount of investment resources necessary for the formation

of investment potential is an important part of the state regulation of investment activity of construction organizations and is being developed in a phased manner.

3.1. Stage 1. Selection of formalized factors, essential in terms of building investment potential of the construction industry

Theoretically, the number of factors for constructing a model of analysis that could be selected to determine the investment potential of the construction sector is quite significant, because its investment potential is shaped by the following factors: natural resource, socio-labor, innovation, economic, institutional, infrastructural, financial, consumer etc. However, the application of a number of provisions of the theory of systems, namely, the principles of the necessary variety of system elements, the minimum sufficiency and the target orientation of these elements, allows you to limit their number. Choice formal factors significant in terms of increasing the investment potential of the construction industry, will hold based on the availability and accessibility of statistical information. According to researches of the National Institute for Strategic Studies under the President of Ukraine, the level of investment (use) of capital investments is highlighted by the level of investment attractiveness of the industry and among the main factors influencing the formation of investors' preferences and forming the investment potential of the industry, the attraction of foreign direct investment and the state of fixed assets are considered. In modeling the investment potential of the construction industry as the initial characteristics of the model, we will consider the growth rate of capital investments (the ratio of investment volume for the current year to the volume of investments in the previous period). The main determinants of the impact on the investment potential of the construction industry are as follows:

- the growth rate of foreign direct investment (equity) (calculated as the ratio of annual FDI inflows to the sector in the current year to the amount of the previous year);
- the growth rate of construction (the indicator of the dynamics of construction, calculated as the ratio of the volume of construction work performed in the current year to the volume of construction work in the previous year (the index of the volume of construction works));
- growth factor of fixed assets of the industry (ratio of the amount of fixed assets at the end of the year to their value at the beginning of the year).

3.2. Stage 2. Selecting a mathematical model

Research of the investment potential of the construction industry is carried out with the help of three-factor production function:

$$Y = F(X_1, X_2, X_3).$$

3.3. Stage 3. Collecting the necessary information

Calculations of components in the assessment of the investment attractiveness of the construction industry are based on the information of the State Statistics Service of Ukraine and are shown in Table 1.

It should be noted that in 2014, foreign direct investment in Ukraine decreased significantly due to the sharp drop in hryvnia and outflow of equity.

Table following on th next page

*Table 1: Indicators for the analysis of the investment potential of the construction industry
(State Statistics Service of Ukraine, <http://www.ukrproject.gov.ua>)*

Year	Indexes			
	the growth rate of capital investment	the rate of growth of foreign direct investment (equity)	the growth rate of construction	growth factor of fixed assets of the industry
	Y_i	X_{1i}	X_{2i}	X_{3i}
2001	1,40	1,30	0,90	1,01
2002	1,64	1,40	0,84	1,02
2003	1,37	1,44	1,15	1,08
2004	1,88	1,73	1,10	1,04
2005	1,09	3,48	0,93	1,10
2006	1,28	0,60	1,09	1,21
2007	1,47	1,68	1,10	1,28
2008	1,37	0,77	0,85	1,41
2009	0,49	0,70	0,40	1,10
2010	0,93	1,07	0,79	1,03
2011	1,72	1,16	1,16	1,17
2012	0,97	0,90	0,92	1,02
2013	1,08	0,58	0,89	1,17
2014	0,98	0,001	0,78	0,99

3.4. Stage 4. Conducting calculations

3.4.1. Stage 4.1 Construction of three-factor production function

We are aware of the statistical data of individual components of the investment potential of the industry for the n previous periods.

Y – factor resulting investment potential of the construction industry;

X_1, X_2, X_3 – key factors of investment potential .

Let's denote:

Y_i – the value of the resulting factor, in the i -period;

X_{ji} – the value of j -factor in that i -period.

Then the table 1 in the symbolic form will have the following form (table 2).

Table 2: Values of the factors studied

№	Y	X_1	X_2	X_3
1	Y_1	X_{11}	X_{21}	X_{31}
2	Y_2	X_{12}	X_{22}	X_{32}
.....				
i	Y_i	X_{1i}	X_{2i}	X_{3i}
.....				
n	Y_n	X_{1n}	X_{2n}	X_{3n}

Table 2 actually establishes a functional relationship between the resulting factor Y and factors X_1, X_2, X_3 , i.e. Y is a function of three variables. The given functional dependence is represented by a formula based on the theory of production functions, which was developed by American

scholars D. Cobb and P. Douglas, who proposed one of the most well-known varieties of production functions, called the function of Cobb-Douglas.

General view of this feature:

$$Y = A \prod_{i=1}^n x_i^{a_i}, \quad (1)$$

where Y – resultant factor;

A – numerical parameter of the production function;

X_i – i -th argument, that is the value of the i -th factor of the production function;

a_i – index of the degree of the i -th argument.

In our case, we will have:

$$Y = AX_1^{a_1} X_2^{a_2} X_3^{a_3}. \quad (2)$$

Performing logarithmic operations (2) we get:

$$\ln Y = \ln A + a_1 \ln X_1 + a_2 \ln X_2 + a_3 \ln X_3, \quad (3)$$

or after replacement

$$\begin{aligned} \ln Y = y, \ln A = a_0, \ln X_1 = x_1, \ln X_2 = x_2, \ln X_3 = x_3 \\ y = a_0 + a_1 x_1 + a_2 x_2 + a_3 x_3. \end{aligned} \quad (4)$$

Let's denote through

$y_i = \ln Y_i, x_{ij} = \ln X_i (i = 1, \dots, n), (j = 1, 2, 3)$ – the value of the new variables in the i -th period.

Equation (4) for the i -th period takes the form:

$$y_i = a_0 + a_1 x_{1i} + a_2 x_{2i} + a_3 x_{3i}. (i = 1, \dots, n) \quad (5)$$

In fact (5) is a system of linear algebraic equations. Such a system for $n > 4$, according to the Kronecker-Capelli theorem, has no precise solution, so we will try to (5) execute approximately, but with the slightest error.

$$y_i \approx a_0 + a_1 x_{1i} + a_2 x_{2i} + a_3 x_{3i}. \quad (6)$$

Apply to (6) the method of least squares. To do this, we write the target function

$$S = \sum_{i=1}^n [y_i - a_0 - a_1 x_{1i} - a_2 x_{2i} - a_3 x_{3i}]^2 \rightarrow \min, \quad (7)$$

where $S = S(a_0, a_1, a_2, a_3)$.

According to Fermat's theorem for finding the extremum of the function S , we find its partial derivatives and equate to zero:

$$\left\{ \begin{array}{l} \frac{dS}{da_0} = -2 \sum_{i=1}^n [y_i - a_0 - a_1 x_{1i} - a_2 x_{2i} - a_3 x_{3i}] = 0; \\ \frac{dS}{da_1} = -2 \sum_{i=1}^n [y_i - a_0 - a_1 x_{1i} - a_2 x_{2i} - a_3 x_{3i}] x_{1i} = 0; \\ \frac{dS}{da_2} = -2 \sum_{i=1}^n [y_i - a_0 - a_1 x_{1i} - a_2 x_{2i} - a_3 x_{3i}] x_{2i} = 0; \\ \frac{dS}{da_3} = -2 \sum_{i=1}^n [y_i - a_0 - a_1 x_{1i} - a_2 x_{2i} - a_3 x_{3i}] x_{3i} = 0. \end{array} \right. \quad (8)$$

After the transformations we will have:

$$\begin{aligned} a_0 n + a_1 \sum_{i=1}^n x_{1i} + a_2 \sum_{i=1}^n x_{2i} + a_3 \sum_{i=1}^n x_{3i} &= \sum_{i=1}^n y_i; \\ a_0 \sum_{i=1}^n x_{1i} + a_1 \sum_{i=1}^n x_{1i}^2 + a_2 \sum_{i=1}^n x_{1i} x_{2i} + a_3 \sum_{i=1}^n x_{1i} x_{3i} &= \sum_{i=1}^n y_i x_{1i}; \\ a_0 \sum_{i=1}^n x_{2i} + a_1 \sum_{i=1}^n x_{1i} x_{2i} + a_2 \sum_{i=1}^n x_{2i}^2 + a_3 \sum_{i=1}^n x_{2i} x_{3i} &= \sum_{i=1}^n y_i x_{2i}; \\ a_0 \sum_{i=1}^n x_{3i} + a_1 \sum_{i=1}^n x_{1i} x_{3i} + a_2 \sum_{i=1}^n x_{2i} x_{3i} + a_3 \sum_{i=1}^n x_{3i}^2 &= \sum_{i=1}^n y_i x_{3i}. \end{aligned} \quad (9)$$

or in matrix form (B):

$$\begin{pmatrix} n & \sum_{i=1}^n x_{1i} & \sum_{i=1}^n x_{2i} & \sum_{i=1}^n x_{3i} \\ \sum_{i=1}^n x_{1i} & \sum_{i=1}^n x_{1i}^2 & \sum_{i=1}^n x_{1i} x_{2i} & \sum_{i=1}^n x_{1i} x_{3i} \\ \sum_{i=1}^n x_{2i} & \sum_{i=1}^n x_{1i} x_{2i} & \sum_{i=1}^n x_{2i}^2 & \sum_{i=1}^n x_{2i} x_{3i} \\ \sum_{i=1}^n x_{3i} & \sum_{i=1}^n x_{1i} x_{3i} & \sum_{i=1}^n x_{2i} x_{3i} & \sum_{i=1}^n x_{3i}^2 \end{pmatrix} \begin{pmatrix} a_0 \\ a_1 \\ a_2 \\ a_3 \end{pmatrix} = \begin{pmatrix} \sum_{i=1}^n y_i \\ \sum_{i=1}^n y_i x_{1i} \\ \sum_{i=1}^n y_i x_{2i} \\ \sum_{i=1}^n y_i x_{3i} \end{pmatrix}; \quad (10)$$

By the method of the inverse matrix (10) we find the components of the desired vector a_0, a_1, a_2, a_3 .

From here: $A = e^{a_0}$.

3.4.2. Stage 4.2 Numerical calculations

We are building a matrix B :

$$B = \begin{pmatrix} n & \sum_{i=1}^n x_{1i} & \sum_{i=1}^n x_{2i} & \sum_{i=1}^n x_{3i} \\ \sum_{i=1}^n x_{1i} & \sum_{i=1}^n x_{1i}^2 & \sum_{i=1}^n x_{1i}x_{2i} & \sum_{i=1}^n x_{1i}x_{3i} \\ \sum_{i=1}^n x_{2i} & \sum_{i=1}^n x_{1i}x_{2i} & \sum_{i=1}^n x_{2i}^2 & \sum_{i=1}^n x_{2i}x_{3i} \\ \sum_{i=1}^n x_{3i} & \sum_{i=1}^n x_{1i}x_{3i} & \sum_{i=1}^n x_{2i}x_{3i} & \sum_{i=1}^n x_{3i}^2 \end{pmatrix} = \begin{pmatrix} 14 & -5,1978 & -1,5502 & 1,4694 \\ -5,1978 & 50,9610 & 2,0984 & 0,0758 \\ -1,5502 & 2,0984 & 1,1178 & -0,1021 \\ 1,4694 & 0,0758 & -0,1021 & 0,2912 \end{pmatrix};$$

$$\mathbf{b} = \begin{pmatrix} a_0 \\ a_1 \\ a_2 \\ a_3 \end{pmatrix} = \begin{pmatrix} 2,5946 \\ 1,2697 \\ 0,7329 \\ 0,3452 \end{pmatrix}. \quad (11)$$

The inverse matrix \hat{A}^{-1} will look:

$$B^{-1} = \begin{pmatrix} 0,1877 & 0,0142 & 0,1517 & -0,8977 \\ 0,0142 & 0,0225 & -0,0305 & -0,0884 \\ 0,1517 & -0,0305 & 1,1292 & -0,3616 \\ -0,8977 & -0,0884 & -0,3616 & 7,8592 \end{pmatrix};$$

$$\begin{pmatrix} a_0 \\ a_1 \\ a_2 \\ a_3 \end{pmatrix} = B^{-1}\mathbf{b} = \begin{pmatrix} 0,3064 \\ 0,0126 \\ 1,0576 \\ 0,0067 \end{pmatrix} \quad (12)$$

Then

From here: $A = e^{a_0} = e^{0,3064} = 1,3585$.

Thus, equation (2) will have the form:

$$Y = 1,3585 X_1^{0,0126} X_2^{1,0576} X_3^{0,0067} \quad (13)$$

3.5. Drawing conclusions

The obtained functional dependence allows us to carry out an analysis of the effect of changing the value of one of the selected factors (X_1 , X_2 , X_3) on the resulting factor Y . Thus, according to the results of researches of the National Institute for Strategic Studies under the President of Ukraine [86], the main factors shaping the investment potential of the industry are "the rate of growth of foreign direct investment (equity)" (X_1) affects little, but the influence of the factor

"coefficient of growth of fixed assets of the industry" (X_3) almost absent. The factor "growth rate of construction" (X_2) affects significantly on the resulting factor "the rate of growth of capital investment". Given that the average factor of the "growth factor of fixed assets of the industry" (X_3) is 1,12 (from the table1), $1,12^{0,0067} = 1,0008 \approx 1$ and the impact on the performance indicator is small, then the functional dependence can be expressed:

$$Y = 1,3585 X_1^{0,0126} X_2^{1,0576}. \quad (14)$$

Graphic interpretation of the obtained equation (14) gives a visual representation of the nature of the factors dependence: "the rate of growth of capital investment" (Y), "The growth rate of foreign direct investment (equity)" (X_1) and "the growth rate of construction" (X_2) and shown on Figure 1.

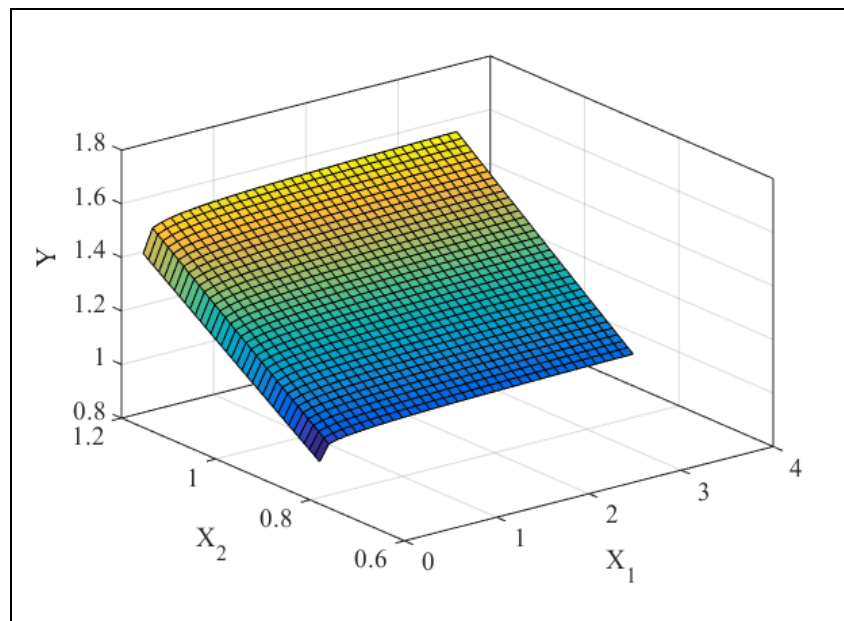

Figure 1: Graphic interpretation functional dependence (14)

Average value $X_1^{0,0126}$ ($1,2^{0,0126}$) equals $1,0023 \approx 1$ and as a result we get the following functional dependence of the resulting factor on the "growth rate of construction", which significantly affects it:

$$Y = 1,3585 X_2^{1,0576}. \quad (15)$$

The graph of function (15) will be a straight line passing through the origin. Thus, the factors X_1 , X_3 do not have a significant impact on the resultant indicator "the rate of growth of capital investment" and in subsequent studies and calculations can not be taken into account. Factor X_2 – The "growth rate of construction" significantly affects the "growth rate of capital investment," which characterizes the investment potential of the industry and the functional dependence has the form (15) (with an increase of X_2 by 1, Y will increase by 1,3585 times). Thus, the sensitivity of the volume of construction products to the integral indicator of capital investment in the construction sector is growing to a large extent. Therefore, the decision to increase the volume of construction products is effective in changing the approaches themselves to increasing the investment potential and the formation of investment policy. Consider the properties of the characteristics of the function (13).

1. Factors elasticity. These figures show how much percent Y will change, if X_i is increased by 1%, leaving other factors unchanged.

For the 1st factor we get

$$E_{x_1} = \frac{x_1 \frac{aY}{ax_1}}{Y} = \frac{x_1 A a_1 X_1^{a_1-1} X_2^{a_2} X_3^{a_3}}{Y} = \frac{a_1 A X_1^{a_1} X_2^{a_2} X_3^{a_3}}{Y} = \frac{a_1 Y}{Y} = a_1 \quad (16)$$

where E_{x_1} – elasticity of the 1st factor.

Thus, for the i-th factor we obtain

$$E_{x_j} = a_j. \quad (17)$$

If X_2 – the growth rate of construction increase by 1%, leaving unchanged other factors, then Y – growth rate of capital investment will increase by 1,0576 %. Similarly, with an increase of 1% X_1 – the rate of growth of direct foreign investment (equity) or X_3 – the growth factor of fixed assets industry remaining unchanged other factors, Y will increase - the growth rate of capital investments by 0.0126% and 0.0067%, respectively.

2. Limiting factor productivity. With an increase in the i-th factor per unit, the resultant factor will increase by magnitude $\frac{\partial Y}{\partial X_i}$. In practice, when planning incomes and expenditures, it is often erroneously believed that the magnitude of the increase is $\frac{Y}{X_i}$.

So, for the 1st factor we get

$$\begin{aligned} \frac{\partial Y}{\partial X} &= a_1 A X_1^{a_1-1} X_2^{a_2} X_3^{a_3}; \\ \frac{Y}{X_1} &= A X_1^{a_1-1} X_2^{a_2} X_3^{a_3}; \\ \frac{\partial Y}{\partial X_1} &= a_1 \frac{Y}{X_1} \text{ that is to say } \frac{\partial Y}{\partial X_1} \leq \frac{Y}{X_1}. \end{aligned} \quad (18)$$

Similarly for the 2nd and 3rd factors.

3. Determining the values of the factors necessary to achieve a given resultant factor.

Find the minimum values of the factors X_1, X_2, X_3 , required to achieve a given Y.

To do this, we have the following problem of nonlinear programming:

$$\begin{cases} I = X_1 + X_2 + X_3 \rightarrow \min; \\ A X_1^{a_1} X_2^{a_2} X_3^{a_3} = Y; \\ X_1; X_2; X_3 \geq 0. \end{cases} \quad (19)$$

To solve it, we apply the Lagrange multiplier method.

$$L(X_1; X_2; X_3) = X_1 + X_2 + X_3 + \lambda [Y - A X_1^{a_1} X_2^{a_2} X_3^{a_3}] \rightarrow \max. \quad (20)$$

$$\begin{cases} \frac{dL}{dX_1} = 1 - \lambda(a_1 A X_1^{a_1-1} X_2^{a_2} X_3^{a_3}) = 0; \\ \frac{dL}{dX_2} = 1 - \lambda(a_2 A X_1^{a_1} X_2^{a_2-1} X_3^{a_3}) = 0; \\ \frac{dL}{dX_3} = 1 - \lambda(a_3 A X_1^{a_1} X_2^{a_2} X_3^{a_3-1}) = 0; \\ \frac{dL}{d\lambda} = Y - A X_1^{a_1} X_2^{a_2} X_3^{a_3} = 0. \end{cases} \quad (21)$$

Conditions of optimality

$$\begin{aligned} \frac{1}{\lambda} &= a_1 A X_1^{a_1-1} X_2^{a_2} X_3^{a_3} = a_2 A X_1^{a_1} X_2^{a_2-1} X_3^{a_3} = a_3 A X_1^{a_1} X_2^{a_2} X_3^{a_3-1} \rightarrow \\ &\rightarrow \frac{a_1}{x_1} = \frac{a_2}{x_2} = \frac{a_3}{x_3}. \end{aligned} \quad (22)$$

We will make a replacement X – to a new variable $X_i = a_i X$. Then the optimality conditions will be fulfilled for any X . We substitute in the fourth equation of the system (21) equality $X_i = a_i X$ and find X :

$$\begin{aligned} Y - A(a_1 X)^{a_1} (a_2 X)^{a_2} (a_3 X)^{a_3} &= 0; \\ A(a_1 X)^{a_1} (a_2 X)^{a_2} (a_3 X)^{a_3} &= Y; \\ A a_1^{a_1} \times a_2^{a_2} \times a_3^{a_3} \times X^{a_1+a_2+a_3} &= Y; \\ X^{a_1+a_2+a_3} &= \frac{Y}{A a_1^{a_1} a_2^{a_2} a_3^{a_3}}; \\ X &= \left(\frac{Y}{A a_1^{a_1} a_2^{a_2} a_3^{a_3}} \right)^{1/(a_1+a_2+a_3)}. \end{aligned} \quad (23)$$

Then

$$\begin{aligned} X_i = a_i X &= a_i \left(\frac{Y}{A a_1^{a_1} a_2^{a_2} a_3^{a_3}} \right)^{1/(a_1+a_2+a_3)}; \\ I_{min} &= (a_1 + a_2 + a_3) \left(\frac{Y}{A a_1^{a_1} a_2^{a_2} a_3^{a_3}} \right)^{1/(a_1+a_2+a_3)}. \end{aligned} \quad (24)$$

To achieve a given result factor Y the minimum required index I (sum of factors) will be equal to I_{min} (24), thus it is possible to find the minimum necessary factors of the factors X_1, X_2, X_3 . On the whole, the preliminary assumption about the level of investment potential expansion is mathematically confirmed.

4. CONCLUSION

The article proposes the scientific principles of determining the need for the total volume of investment resources necessary for the formation of investment potential in a four-stage structure with the use of a three-factor production function.

The conducted studies showed that the subjects of market activity, investors can use the proposed mathematical apparatus in order to determine the factors that affect the improvement of the investment potential of the industry, the degree of their influence, determining the values necessary to achieve a given level of investment potential. The results obtained in this article should be used for further substantiation of the priority directions of the state investment policy in the construction industry and the search for effective tools for its implementation.

LITERATURE:

1. Blank I.A. (2006)*Investitsionnyy menedzhment : uchebnyy kurs. 2 izd.* K.: Nika-Tsentr, Elga.
2. Campbell R. McConnell, Stanley L. Brue, Sean M. Flynn. (2013) *Economics: principles, problems, and policies. 18th ed.* New York, McGraw-Hill/Irwin.
3. Chervanov D.M. (1999) *Management of innovation and investment development of enterprises of Ukraine.* K. : Knowledge, KOU.
4. Danilov O.D., Ivashyna H.M., Chumachenko O.H. (2001)*Investuvannia: navch. posib.* K.: Vydavnychiy dim “Kompiuter-pres”.
5. Dolan Edwin J., Lindsay David E. (1992) *Market: microeconomic model.* St. Petersburg: The Printing Yard.
6. European Investment Bank (2017) *Wind of change: Investment in Central, Eastern and South Eastern Europe.* Retrieved 13.05.2018 from http://www.eib.org/attachments/efs/economics_study_wind_of_change_investment_in_cesee_en.pdf
7. Fedoseev V.V. et al. (2002)*Ekonomiko-matematicheskie metody i prikladnyie modeli: ucheb. posobie dlya vuzov.* M.:YuNITI.
8. Gitman L.J. (2010)*Principles Of Managerial Finance, 11Th Edition.* Retrieved 13.05.2018 from <http://www.kulker.hu/wp-content/uploads/2013/03/30459588-Principles-of-Managerial-Finance-by-Gitman.pdf>
9. Gogiasvili Salome (2016)Current Issues of the Formation of the Investment Environment and Potential in Georgia. *Creative and Knowledge Society, De Gruyter Open*, 2016(vol. 6(1)), pages 1-13.
10. Grinyova V.M., Koyda V.O., Lepeiko T.I., Koude O.P. (2008)*Investing: a textbook.* Kyiv: Knowledge.
11. Harrison A., Love I., McMillan M.S. (2002) Global Capital Mows and Financial Constraints.*NBER Working Paper*, 2002 (№ 8887).
12. Hoiko A.F. (1999)*Metody otsinky efektyvnosti investytsii ta priorityetni napriamy yikh realizatsii.* K.: Vira-R.
13. Keynes J.M. (1997)*The general theory of employment, interest, and money.* Amherst, NY: Prometheus Books.
14. Konoplitsky V., Filina A. (1996)*This is a business. Glossary of Economic Terms.* Kiev: AlterPres.
15. Layko O.I. (2014)*Transformatsiyni protsesi v Investitsiyniy sistemI ekonomiki UkraYini: monografIya.* Odesa: FOP GrIn D.S.
16. Lisyuk V.M. (2011)*Vosproizvodstvennaya funktsiya tovarnyih ryinkov.* Odesa: IPREED NAN UkraYini.
17. Masse P. (1971)*Criteria and Methods of Optimal Determination of Capital Investment.* Moscow: Statistics.
18. Mayorova T.V. et al. (2012)*Aktivizatsiya investitsionnogo protsesa v Ukraine: kollektivnaya monografiya.* M.: Finansyi.
19. Merkulov J.S. (2010)*Investments: a tutorial.* Moscow: INFRA-M.
20. Mocherny S.V. (2000)*Economic Encyclopedia: 3 t. for ed.* K.: Center "Academy", V. 1.

21. Moroz A.M. et al. (1993) *Bank Encyclopedia*. - K.: Track.
22. Pokatayeva K.P. (2007) Theoretical aspects of definition of categories "investment potential" and "investment attractiveness". *Kommunal'noe hojeystvo of cities: scientific and technical. Sat Series: Economic Sciences*, 2007 (№ 75), pages 262-268.
23. Pokropivny O.F. (1995) *Economy of the enterprise: a textbook for the studio. econ universities and fac. : in 2 vols.* K.: Wave Press, V. 1.
24. Sharp W.F., Aleksander G.J., Beyli J.V. (2001) *Investitsii*. M.: Infra-M.
25. Sharpe W. (2006) *Investors and Markets: Portfolio Choices, Asset Prices, and Investment Advice (Princeton Lectures in Finance)*. Hardcover – October 22.
26. So I., Staskevicius A. (2015) *Measuring the "impact" in impact investing*. MBA Harvard Business School Faculty Supervisor: Alnoor Ebrahim. <https://www.hbs.edu/socialenterprise/Documents/MeasuringImpact.pdf>
27. Van Horn D., Vahovich D. (2008) *Osnovyi finansovogo menedzhmenta: Per. s angl. 12-e izd.* M.: Vilyams.
28. Zubkova V.I., Nakyaylo A.V., Losev S.A. (2001) The financial and investment potential of the enterprise and its influence on the management of investments. *Culture of the peoples of the Black Sea region*, 2001 (№ 20), pages 34-37.

DEVELOPMENT OF BUSINESS EDUCATION IN UKRAINE

Viktoriia Kryvoruchko

Odessa State Academy of Civil Engineering and Architecture, Ukraine

vitycy@rambler.ru

ABSTRACT

Business education is the kind of occupational education of high demand. Business education is a relatively new phenomenon in the Ukrainian market of educational services. The constant increase in the need to update knowledge and the increase in requirements for its quality under the conditions of globalization of the educational space require a corresponding offer in the market. The growth of competition in the context of increasing the influence of global factors of the international environment requires to utilize the efficient methods of attracting and retaining customers in most world markets as well as in the markets of Ukraine. Business education is one of the most dynamic sectors of the educational field. The processes of providing services in the business education market require the study and development of certain criteria and standards. The failure of higher educational institutions to solve the development problems of enterprises in the conditions of hyperinflation created the necessity of mastering new market knowledge and skills in the shortest possible time. The experience of economically developed countries also points to the fact that education in entrepreneurship and management is one of the most important factors to successfully complete the transition period to the market economy. However, the foreign experience requires adaptation and rethinking in order to apply the integration of Ukrainian education into the world educational space. During the last decade, Ukrainian business education has demonstrated the activity, dynamism and abilities associated with the assimilation of foreign experience. The significant advantage was the absence of negative attitudes toward any managerial schools of science in particular. In a good sense, such whateverism made it possible to accumulate the educational experience of managers in both American and European business schools. Both occupational education as a whole and business education as an integral part of it are undoubtedly the most important factors of economic growth and socio-economic development at the present stage of the transition to an innovative type of economy. The term "business education" is traditionally understood as supplementary education programs, the top of which are MBA programs. The classical understanding of MBA (Master of Business Administration) is post-graduate specialized occupational training of managers of the highest qualification in the field of business. The urgent character of business education in the national practice is countered by the almost completely irregular way of providing this extremely important type of modern education. The point at issue is that at both the state and private levels, business education should become increasingly more international in its nature.

Keywords: *business schools, economic education, management education, models of business education, postgraduate education*

1. INTRODUCTION

Human potential and human capital are the dominant factors of innovative development. Education is one of the most important directions for the formation of an innovation-oriented institutional environment. (Rakova L., 2011) The current state of Ukrainian education generally meets the need for economic and social development of society as a whole. However, in education there is a need for the training of high professionalism of individual specialists and organizations. Modernization of the occupational education system becomes the basis for dynamic economic growth and social development of society, the factor of well-being of citizens and security of the country, and the necessary condition for the formation of an

innovative economy (Rakova L., 2011). Business education is the kind of occupational education of high demand. Business education is a relatively new phenomenon in the Ukrainian market of educational services. The constant increase in the need to update knowledge and the increase in requirements for its quality under the conditions of globalization of the educational space require a corresponding offer in the market. The growth of competition in the context of increasing the influence of global factors of the international environment requires to utilize the efficient methods of attracting and retaining customers in most world markets as well as in the markets of Ukraine. In comparison with business, education in most cases remains considerably more conservative. The rapid development of this service sector was facilitated by market relations, the acute need for efficient management, the forced transition of scientific and engineering staff to business. In Ukraine, these services have been traditionally provided by institutes for continuing education. They provided the functioning of the system of training, retraining and advanced training of personnel for the management of state enterprises and institutions. In this sense, business education is also often considered as an element of management education, that is, a special subsystem of the management theory. In addition, business education is a special and extremely important example of lifelong learning. The ultimate goal of economic education is to form the system of economic knowledge of a student. However, business education has its ultimate goal, first of all, to train a successful businessman (businesswoman). Nowadays business is less interested in theoretical knowledge, while the concrete results are of great interest, namely the ability to use own knowledge in practice: to quickly analyse information, to make decisions under the conditions of uncertainty (Baranovskaya A., 2016). The analysis of existing trends and perspectives of business education requires to consider the factors influencing its development. At the same time, the issues of the formation and development of the business education market are not sufficiently reflected in the Ukrainian scientific literature.

2. CONCEPT AND DEVELOPMENT OF BUSINESS EDUCATION IN UKRAINE

Business education is one of the most dynamic sectors of the educational field. The processes of providing services in the business education market require the study and development of certain criteria and standards. The failure of higher educational institutions to solve the development problems of enterprises in the conditions of hyperinflation created the necessity of mastering new market knowledge and skills in the shortest possible time. The experience of economically developed countries also points to the fact that education in entrepreneurship and management is one of the most important factors to successfully complete the transition period to the market economy (Opatska, S.V., 2002, p.18). Business education is the most dynamic segment of the market. However, the foreign experience requires adaptation and rethinking in order to apply the integration of Ukrainian education into the world educational space. The educational sphere is conservative in principle and it cannot be different. However, business education should be the most dynamic sector in the conservative educational field. After all, it is closest to the entrepreneurial sphere, its direct partners are those who have to advance the new economy (Rakova L., 2011). Business education is one of the most modern and most promising directions in providing economic education in the broad sense of the word.

2.1. Factors influencing business education

Business education occupies a special place within the system of occupational education. On the one hand, business education provides the formation and development of human capital, which is the basis of innovative transformations of a society characterized by post-industrial tendencies. On the other hand, it is business education that actively interacts with another institution which is equally important for achievement of the set priorities of innovation development - the institution of entrepreneurship (Rakova L., 2011).

However, even a brief review of professional economic literature shows that the academic status of business education itself is still unclear. Economic education is needed both for heads of large state-owned enterprises and organizations and for subordinate executives. And the business education is mostly needed for conducting own private business. In the world, business education is mainly provided by non-state and private educational institutions – in most cases, numerous business schools. In Ukraine, business education is still not regulated even at the legislative level. The notion of business education is absent in the Law of Ukraine “On Higher Education”. At both the state and private levels, business education should become more international in nature (Zhyhlyevych O., 2017). Analysing economic factors, it is worth pointing out that business education certainly depends on the level of socio-economic development of both the world and a certain country. It provides training for managers who play a key role in business processes. In addition, according to researchers, economic development requires new managers, and depending on the economic situation, the demand for educational services is changing; a favourable economic environment usually has a positive impact on the development of business education (Shkliaruk K., Bidiuk A., 2014). Formation and use of marketing tools is a prerequisite for the successful activities of enterprises using them. As for segmentation of consumers in the market of business education, N. Kuznetsova insists on the existence of two types of consumers – corporate and individual. (Kuznetsova N., 2009, p.150) The corporate consumers are divided according to professions (specialties) and management levels. The individual ones are differentiated by age, sex, type of occupation, and also by features that are similar to corporate consumers. In addition, both types of customers are classified according to the resources they are willing to spend on training – time, money, and place. This approach is narrow to some extent, since only personal (socio-economic) criteria are considered, and the peculiarities of segmentation of industrial enterprises are almost not taken into account. S. Filonovych notes that potential customers need different skills depending on the level of management. The managers of lower level are interested in improving personal efficiency, developing professional skills. In such a case, they often leave the possibility to change the job open. The mid-level managers focus on career development, solving more complex tasks, and they need knowledge concerning relevant technologies and algorithms. The top managers are interested in solving problems of an enterprise. The key issues for them are systematic approaches, logic and philosophy, understanding of business, status, development of relationships with the external environment, and business communication (Filonovych, S., 2004, p.218). Following the scientists who considered this issue, the following key factors can be distinguished which have a certain impact on business education, namely: economic, socio-demographic and educational in fact. (Shkliaruk K., Bidiuk A., 2014) In economic terms, business education is defined as a factor for the development of effective entrepreneurship. One of the most important tasks for the development of small and medium-sized businesses in Ukraine is the use of market-oriented management and the provision of professional management by improving the training system of middle and upper-level managers. The foregoing suggests that the formation of an effective marketing component for the activities of enterprises in the market of business education will not only improve their results but also the development of the market as a whole (Borovska, O., 2013). A number of important socio-demographic trends affect the modern development processes of business education market. The number of prospective university students who intend to obtain at least economic education directly depends on the population. The demographic situation in Ukraine is characterized by a negative tendency to decrease the population since independence. In recent years, there has been a gradual decrease in the number of permanent residents of Ukraine. However, an increase in the quality of education will create an influx of those wishing to get the economic knowledge. The training of personnel should be an important step towards the improvement of staffing resources – the accumulation of not only knowledge but also

management skills as well as the creation of conditions for the implementation of continuous education – the life-long education in accordance with socio-economic, technological and socio-cultural changes in society. The role of the business education system focused on the training and professional development of not only managers and functional specialists of large companies, but also entrepreneurs representing small and medium-sized businesses, is absolutely obvious. It is small and medium-sized businesses which are the foundation of the innovative development of the economy, and it is the business education which forms the necessary institutional environment for the construction of this foundation (Rakova L., 2011). To accomplish the latter goal, it is generally not necessary to master the entire system of economic knowledge; the practical orientation of education dominates here and it clearly prevails and almost completely displaces the component of the so-called “fundamental science”, and hence most of the classical “fundamental education”. The Ukrainian researcher Velushchak M. describes the correlation of economic education and business education in the United States – the country where business education has received the highest degree of development and has proven convincing results – as follows: “Researching the peculiarities of the training of specialists in economics in the US, the notions of economic education and business education should be distinguished. The economic education is more theoretical and provides training for specialists in public institutions, while business schools teach practitioners to work in the private sector.” (Velushchak M., 2012, p.170) As we can see, the difference in the purpose of studying in the United States is related not so much to theory and practice, but to the work in different spheres of the economy: the macro level requires more education which gives a more comprehensive vision of economy functioning – namely, as the integral economy of a country, and perhaps even as a component of the world economy in all (or at least most of them) aspects of its development.

2.2. Formation of business education in Ukraine

The need for business education emerged in the early 90's, when the economic system changed in Ukraine and gradual changes were made in the structure of the national economy. Since at the time of declaration of independence, the structure of the profiles for training of specialists in certain areas was in line with the needs of the command and administrative economy, the current educational level of the population in relation to the conduct of entrepreneurial activities is insufficient. Taking into account the changes that have taken place in Ukraine, the topical issue is to train the largest part of the able-bodied population for conducting economic activities in a market environment. Thus, in Ukraine there is a need to intensify business education (The National Business Education Association). The phase of rapid growth in the sphere of business education, which is typical for the formation period of the home market of educational services, is now being transformed into an organizational phase or a systematization phase. The actuality to form and develop the system of business education is obvious, and it should comprise both state and non-state institutions of higher occupational education. (Rakova L., 2011). However, there is no systematic learning in such combination, that destroys the quality of specialist training in certain areas. The absence of such a system is currently the most serious problem which impedes the development of this market sector of educational services. The successful transition of the national economy to the innovative way of development largely depends on the degree of “sensitivity” of the education system to technological progress, that is determined by the nature and stability of its relationship with the field of practical activity. The imperfection in the processes of practical training of students during their education, which are often of a formal nature, a significant gap between theory and practice create an informational vacuum in the educational environment. All these factors block the ability to provide high-quality professional knowledge demanded by the labour market. The reality requires to introduce a practical component into the learning process by developing new forms of cooperation between

educational institutions and business. Bilateral agreements should be the key requirement for such cooperation, which will include compulsory training at manufacturing enterprises for teachers of higher education institutions and the involving the teachers of special disciplines for solving their business and economic problems, and establishing quotas of workplaces for manufacturing practice with the further employment of students. These opportunities, to a large extent, will be determined by the degree of legal autonomy of educational institutions and the system of encouraging business to these actions (Krasovska, O., 2012, p.169). In addition, the role should be defined with a special attention to the regional education systems, which are currently characterized by multi-directional trends. The strengthening of the socio-economic role of regions as a whole, that is an objective response to the trends of globalization, is accompanied by a relatively passive reaction of regional education authorities, ineffective activities of various educational institutions, which are unable to offer competitive educational products to consumers. Both occupational education as a whole and business education as an integral part of it are undoubtedly the most important factors of economic growth and socio-economic development at the present stage of the transition to an innovative type of economy. Business education should be currently considered as one of the key elements of innovation infrastructure. In its turn, the business education sector is also the object of organizational innovations focused primarily on the formation of a business education system, increasing the effectiveness of interaction between the subjects of business education market at the international, national and regional levels (Rakova L., 2011). During the last decade, Ukrainian business education has demonstrated the activity, dynamism and abilities associated with the assimilation of foreign experience. The significant advantage was the absence of negative attitudes toward any managerial schools of science in particular. In a good sense, such whateverism made it possible to accumulate the educational experience of managers in both American and European business schools. At the same time, some Ukrainian business schools have excessive ambitions, which are manifested in the persistent assertion of their own beliefs and conceptual approaches. Considering Ukrainian business education in terms of periodization of life cycles, it can be boldly claimed that it has already overcome the initial stage. This stage is related to conducting short-term seminars and trainings that help to solve topical problems of managers as they arise, opening the first long-term programs with the help of foreign colleagues. The next stage is the formation of business education.

3. METHODS OF EDUCATION AND BUSINESS EDUCATION PROGRAMS

Business schools focus on the end user while forming a range of services, but often customer expectations are not met due to crude academic programs, incompetence of trainers or inadequate price/performance ratio. The advantage of higher education institutions is the available research and scientific traditions. At the same time, a new generation of scientific and pedagogical personnel is being gradually formed, and they are oriented at the values of market economy. In some higher educational establishments, professional teachers are gathered on purpose to use innovative techniques for training of management personnel. Due to financial difficulties, it is not always possible to provide the educational process with technical means and literature. In addition, the training methods and programs with unusual content are more expensive to develop and harder to sell in the market. It is much cheaper and easier to use conventional traditional education schemes in spite of their inefficiency from the point of view of business. The potential consumers are accustomed to such schemes. The risk of mistake is also supplemented by the fact that decisions on innovations in business schools in Ukraine are taken deliberately in violation of the requirements of state executive authorities (the content of programs required by the Ministry of Education and Science of Ukraine). The desire to dictate what and how to teach within the framework of programs is also characteristic of the largest

state higher educational institutions which use the Ministry of Education and Science as an appropriate tool for monopolization of the market. (Opatska, S.V., 2002, p.8)

3.1. Training of specialists under the MBA program

In Ukraine, the role of new methodological approaches, educational literature and teachers who can take into account the peculiarities of the Ukrainian market, their own consulting practice, and are not limited to Western experience is growing. The most important step to minimize the stress of that period was the creation of the Ukrainian Association for Development of Management and Business Education (UADMBE) in July of 2002, which united 52 educational institutions and is constantly working on integrating the efforts of educational institutions and businesses in order to introduce modern effective educational and managerial technologies in the field of management and business education in Ukraine. The term “business education” is traditionally understood as supplementary education programs, the top of which are MBA programs. The classical understanding of MBA (Master of Business Administration) is post-graduate specialized occupational training of managers of the highest qualification in the field of business (Tikhonov D., Khazin M., 2013). The qualification of an MBA provides the opportunity to work as a middle and senior manager. Those who aim to learn how to effectively manage their personnel, to properly organize and develop their business are trying to get an MBA degree. An MBA program usually lasts from one to two years. The degree of MBA obtained in one of the TOP business schools in the world is the key to the career of a senior manager in corporations known throughout the world and the opportunity to fully realize own managerial potential (Karpukhina E., 2004, p.81). The problem of qualitative training of specialists in the field of management and the formation of relevant criteria for professional training of management personnel in these areas is directly related to the current functioning conditions of all participants in the social partnership. (Kremenia V., 2004, pp. 132-133) The need for specialists with a high level of intellectual and creative activity is growing. This certainly appears in the field of occupational education, because it is the sphere where the training of new type specialists who are adequate to changing conditions is carried out. Realization of these tasks can be facilitated by substantial foreign experience, but it needs adaptation and rethinking in order to be applied at the national level taking into account globalization processes and integration of Ukrainian education into the world educational space (Obolenska T., 2003, p. 84). There are about 200,000 students in the world who study annually under MBA programs and this figure is constantly increasing. The MBA programs are currently provided in 5 business schools in Ukraine, and during the next five years, there are chances for ten more different variants of this popular program to appear. Taking into account its specific requirements, it is possible that despite its disparity with traditional master's programs, it will create conditions for the convergence of Ukrainian education with the requirements of the Bologna Declaration. Business education, in addition to acquiring an MBA degree, includes at least 27 specialties. (Business education) In addition, it is possible to receive almost the same number of specialties at the previous educational qualification level of the bachelor and at the next educational qualification level of doctor. Meanwhile, the graduates of MBA are becoming more and more in demand on a global basis. However, the demand for specialists with an MBA degree is not homogeneous; the increased demand for specialists is observed in countries with high rates of economic development. (Shkliaruk K., Bidiuk A., 2014) Moreover, the differentiation of demand is increasing. And one of the main trends in the MBA market is the globalization of business education and diploma. In the direction of developing higher education and business education, the latter is a mediator which links the educational field and practical activities. Higher education supplies potential entrants for business schools, and business serves as a “consumer” for business school graduates. According to researchers, the more graduates of universities are, the greater the personnel base for business education is, and, consequently, the greater the demand for its services

is. (Shkliaruk K., Bidiuk A., 2014) The specialists in the field of business education are advised to learn in advance. Knowledge should be received today, and it should be applied in practice tomorrow.

3.2. Models of business education

In the field of business education, which is intensively developing in the modern world and becoming more international, two main models can be distinguished: German and American. Both of them are prototypes for constructing business education systems in other countries. Each of them has its own peculiarities. Despite the fact that Americans claim to get the palm of victory for their education in economics and business, it originated in Europe. That is why the traditional German model is still called continental European. Depending on the practical experience in management, the management education is divided into preexperience management education and post-experience management education. Students obtain the preexperience education in the process of studying in higher educational institutions, where they study law, marketing, economics, etc. at the applied level alongside with main subjects. The obtained knowledge enables the graduate to be considered as a "qualified manager". The post-experience education can be obtained through special short- and medium-term programs of advanced training in various spheres of management. The German model of business education surely prepares highly skilled managers. This is evidenced by the facts that the countries where the German model is used have gained high results in economic development (Karpukhina E., 2004, p.94). Based on the traditional and new models in the business world, a so-called mixed model has emerged which combines Americanized and Europeanized sectors of business education. Training takes place at educational institutions of various types (universities, business schools, institutes for continuing education, etc.) in various forms. The mixed model is the most widespread business education in many European countries, for example, France and Italy. The directions for improving the quality of business education are greatly concerned by the Association to Advance Collegiate Schools of Business (AACSB), the European Foundation for Management Development (EFMD), which directly develop and implement standards for American and European business education institutions; in Central and Eastern Europe, it is the Central and East European Management Development Association (CEEMAN) (Krasovska, O., 2012, p. 168). The peculiarity of the business education model, which is practically applied by all European countries, is the coexistence of the German model, on the one hand, and the American model – on the other hand. In essence, it goes about the degree to which the business education system of a particular country is Americanized, namely whether it offers MBA programs at business schools. The leading role in business education belongs to the Graduate Business Schools, which typically carry out all types of business education programs, namely: four-year bachelor's programs; two-year MBA programs (on a mandatory basis); one-year specialized master's degree programs; three-year (and more) Ph.D. programs as well as development programs for managers. It is important that all these programs are considered in an inseparable organizational and methodological unity. The European Council for Business Education (ECBE) was established with the aim of supporting academic and occupational education in business and related fields. It is an international non-profit educational organization registered in Brussels as AISBL, an international non-profit organization. ECBE provides advice to encourage and support institutions to take on their responsibilities to continuously improve educational processes. These services help improve the learning environment and career development opportunities for business students. The ECBE mission is to support a great number of education and training institutions in their development of outstanding, innovative programs that will help students develop their skills, knowledge and experience in order to succeed in today's dynamic global economy. Thanks to its accreditation, ECBE helps to ensure that accredited members meet the requirements of the European Higher

Education Area (EHEA) as outlined in the Bologna Process documents and other EU Directives (Welcome to ECBE.EU). In Ukraine, most people mistakenly believe that business education exists only for those who want to graduate and eventually build a career in business. However, today everyone should understand how the market economy works. That is why it is necessary to change the understanding of the role of business in economic development and, accordingly, the importance and objectives of business education. Students planning their future activities as entrepreneurs must first of all understand the principles of doing business. Young people, whose future will be connected with medicine, jurisprudence, and science, must also understand that their activities are not likely to be successful without understanding the principles of doing business. Such functional divisions of business as marketing, management, accounting, production, and finance must work together (The National Business Education Association). While fulfilling this task, even the systematic and functional features of management, competition inherent to economy, and the pursuit of profit go to the background for some time. Therefore, without understanding the educational component of business education, it can be easily transformed into a passion for management for the sake of management. While the main thing in business education is the urge for business development through human development and human development through business development. Therefore, most people preferred to study business in Europe. However, the benefits of Western education lose their weight to some extent in Ukraine. Despite these difficulties, the demand for business education in Ukraine was formed for objective reasons: the need for new knowledge was growing with the development of the market and business. And in order to get it in the West, you must perfectly know English at least, have the opportunity to go abroad for 1,5-2 years and have the necessary funds for that. As a rule, the connections have value in the environment in which a person works constantly.

4. CONCLUSION

The experts in the field of business education advise to study in advance. Knowledge must be received today and applied tomorrow. Learning "with room to grow" will help in the future to prevent useless and economically inappropriate repetition of the past. Every person has a sphere of immediate development (Karpukhina E., 2004, p. 215). All this testifies to the fact that business education, growing in competition with the economic education and on the basis of a significant part of the elements from the traditional economic education, is increasingly displacing the latter. However, the fact that the greater success in providing business education belongs to private institutions attracts attention to the specifics of business management and the peculiarities of public administration. Thus, in contrast to the public sector, in private institutions, on the one hand, spontaneity and initiative are encouraged much more, and on the other hand, the incomparably higher degree of personal responsibility for the quality of the result is emphasized. The actuality of business education in domestic practice is countered by the almost complete irregularity in providing this extremely important type of modern education. The point at issue is that at both the state and private levels, business education should become increasingly international in nature. Taking into account the specific requirements of business education with all its disparity with traditional master's programs, it is possible to create conditions for the convergence of Ukrainian education with the requirements of the Bologna Declaration (this refers to the development and spread of the European credit system as the basis for assessment and planning of the workload for students - the formation of conditions for the possible and effective student exchange, continuing education in various business schools, intensive exchange of teachers, the establishment of individual system of life learning). According to the Bologna Declaration, this zone is acting on a general basis and it should ensure the introduction of two-cycle training, the expansion of student mobility and the employment of graduates, the introduction of the credit systems necessary for this (accumulation of credit hours according to the ECTS system) and the

education quality control, and consequently lead to the increase of competitiveness and attractiveness of the European education system. This is one of the main guarantees not only for gaining experience but also involving the demand for specialists trained in business education to the world market. The lack of full state support in Ukraine is definitely a negative phenomenon. Although this means the possibility of developing any forms of business education without being regulated, but makes it difficult to provide a state-recognized diploma after obtaining such education. At the same time, the development of business education can become one of the leading factors in the effective development of the domestic business environment. Thus, the experts trained in Ukraine should know the requirements and requests for doing business in the world – both for taking on international business projects and for effective international mobility of workers and business professionals themselves. The market needs international transit of not only goods and services, but also consumers and producers of these services. So in business education, the interests of seemingly the fiercest rivals in business and the irreconcilable management schools are combined. In such a case, business education should be developed both as a special direction of providing higher, second and postgraduate education, and as part of all these types of education – based on the consideration of business education as lifelong education.

LITERATURE:

1. Baranovskaya, A. (2016). Modern Concepts of Public Administration in Relation to System of Business Education. Retrieved from: <http://sci-article.ru/stat.php?i=1476297887>.
2. Borovska, O. (2013). *Business Education in Ukraine – Myth or Reality?* Retrieved from: www.osvita.org.ua/mba/articles/22.html.
3. Business Education. *Wikipedia, the free encyclopedia*. Retrieved from: https://en.wikipedia.org/wiki/Business_education.
4. Filonovich, S. (2004). Business Education: Specificity, Programs, Technology, Organization. *Publishing House GU VSHE*, Moscow, Russia, 690 p.
5. Karpukhina, E. (2004). Strategic Alliances in Business Education. *Business Education: Specifics, Programs, Technologies, Organization*, Economy, Moscow, Russia, 390 p.
6. Krasovska, O. (2012). Current Models of Implementation of Business Education in Globalized World Educational Space, *Bulletin of the International Nobel Economic Forum*, No. 1 (5), Vol. 2, pp. 167-171.
7. Kremenia, V. (2004). *Higher Education in Ukraine and the Bologna Process: Study Guide* [Higher Education in Ukraine and the Bologna Process: Study Guide], Navchalna knyha – Bohdan, Ternopil, Ukraine, 384 p.
8. Kuznetsova, N. (2009). Business Education as a Factor of Improving the Quality and Competitiveness of Administrative Staff in Educational Space Integration. *Collection of Scientific Papers*, ChSTU, vol. 22, Part 1, pp. 148-151.
9. Obolenska, T. (2003). Globalization and Strategic Development Directions of Educational Services Market in Ukrainian. *Collection of Scientific Papers “Economics: Problems of Theory and Practice”*, Vol. 113, pp. 84–87.
10. Opatska, S. (2002). Development of Business Education in Ukraine in Transforming Economy, *Thesis abstract for Cand. Sc. (Econ.)*, 08.09.01, Institute of Regional Studies, Lviv, Ukraine, 24 p.
11. Rakova, L. (2011). Business Education as Factor of Innovative Development of Economy. Retrieved from: http://www.rusnauka.com/1_NIO_2011/Economics/77475.doc.htm.
12. Shkliaruk, K., Bidiuk, A. (2014). Business Education: Time Challenges and Developmental Factors. *Bulletin of the Kiev National Trade and Economic University*, No.2. Retrieved from: <http://visnik.knteu.kiev.Ua/files/2014/02/11.pdf>.

13. *The National Business Education Association*. Retrieved from: <https://www.nbea.org/newsite/about/index.html>.
14. Tikhonov, D., Khazin, M. (2013). Business education: new model. Retrieved from: <http://hrm.ru/biznes-obrazovanie-novaja-model>.
15. Velushchak, M. (2012). Structure of Higher Economic Education in USA. *Comparative Professional Pedagogy*, No. 2, pp. 169-174.
16. *Welcome to ECBE.EU*. Retrieved from: <http://www.ecbe.eu/index.php?id=2>.
17. Zhyhylevych, O. (2017). Business Education in Structure of Management Education and Philosophy of Economy (Philosophical and Educational Conceptualization). *Science Journal. Series "Philosophy"*, Vol. 48 (Part I), pp.170-181. Retrieved from: <http://doi.org/105281/zenodo.546422>.

APPLICATION OF METHODS OF CATASTROPHE THEORY IN THE TECHNOLOGY OF CONSTRUCTION COMPOSITE MATERIALS

Larysa Trofimova

*Odessa State Academy of Civil Engineering and Architecture, Ukraine
lara.reverberator119@gmail.com*

ABSTRACT

It is known that construction composite materials (mortars and concretes based on mineral or organic cements, slips for making ceramics, coating compositions and many other such dispersions) may be approached as self-organizing systems, the evolution of which in time and space is accompanied by apparition of dissipative structures. Since most above-named systems are characterised by stick-slip phenomena conditioned by interruption of continuity in developing processes of various types, it is proposed to enrich the synergetic approach to studying structure formation particularities with methods of catastrophe theory, which is studying sudden qualitative system reformations resulting from smooth change of external conditions or internal properties. For a number of years, the author, under scientific guidance and with consultations of the chief of Laboratory of High Concentration Disperse Systems of the Institute of Physical Chemistry and Electrochemistry of the Russian Science Academy, member of the Russian Academy of Natural Sciences, Doctor of Chemistry N.B. Uriev, have been conducting research with aim of determining the consistent pattern of formation, stability and decomposition of structured disperse systems in heterogeneous chemical technological processes of making construction materials with predetermined structure and predictable performance indicators while reducing resource consumption for their production. Research program includes solution of tasks connected to description and analysis of such phenomena when increasing the intensity of technological treatment leads to qualitatively new system behaviour. Methodological base of research is the analysis of processes of disperse systems structure formation in dynamical and static conditions from the point of view of synergetics and catastrophe theory. Understanding the nature of dispersions abnormal rheological behaviour uncovers the possibility of implementation of optimal dynamic condition of the system and corresponding level of isotropic decomposition of the structure, which is the necessary condition for obtaining materials with requested properties. Therefore, the matter of informational interpretation of non-trivial viscosimetric data has practical importance for solving many material science tasks. Use of new ideas for disperse systems evolution under conditions of different technological operations let us raise physics-chemical processes modeling to the new level to create modern compositions.

Keywords: *Catastrophe Theory, Structure Formation, Systems.*

1. INTRODUCTION

As is known, mortars and concretes based on mineral or organic binders and a great variety of building materials are typical dispersion composites. The technology of obtaining such materials on the basis of disperse systems is characterized by a number of general and typical processes associated with interaction and mutual distribution of dispersion phases [8–10]. Such processes as mixing, transportation, compaction, de-compaction, deformation of basic disperse systems are inevitably accompanied by the formation and disintegration of dispersion structures. These distinctive features of the cross-linking of highly concentrated and highly dispersed systems, under the conditions of dynamic influences, radically influence the technology of high-quality dispersion composite materials. In this regard, the solution of the complex problem of obtaining the majority of construction composites with a given structure and predictable performance criteria while reducing the resource intensity for their production

is inextricably linked with theoretical and experimental studies in the field of physics-chemistry of initial disperse systems. For most structured disperse systems in a variety of heterogeneous chemical-technological processes of the production of composite materials carried out during forced convective diffusion of dispersion phases, the non-equilibrium dynamic state is predominant. Therefore, the determining elements of regulation of these processes should be based on modern concepts and principles of physical and chemical dynamics – the new physics-chemistry scientific direction of disperse systems developed in recent years by N.B. Uriev and his school [9]. The physics-chemical dynamics of disperse systems mainly considers the dynamic processes taking place in the aggregate of particles of disperse phases connected by the action of dispersion forces into the spatial structural grid; the mechanism of the decay of such structures under dynamic conditions with the formation of aggregates out of them; their development, mutual interaction and interaction with the dispersion medium (up to the disintegration into separate particles with the release of the dispersion medium immobilized in them). Along with the processes of destruction of the structure of aggregates within the framework of physical-chemical dynamics, reverse processes of the formation of structures under conditions of dynamic influences on the system are also considered. The basis of the physicochemical dynamics of structured dispersions consists essentially of the understanding of the laws and methods for implementation of the optimal dynamic state of systems. It is in this case that the lowest viscosity level and the corresponding maximum fluidity of the maximally and isotropically destroyed structure (equiprobably in terms of the volume of the system) may be achieved, which is a necessary condition for obtaining materials with specified properties. To describe the processes of development of disperse structures under dynamic conditions, the methods based on rheological measurements are traditionally used with the plotting and analyzing of complete process curves. Understanding the nature of the anomalous rheological behavior of dispersions provides the opportunity of creating a controlled isotropic dynamic state; it serves as the background on which the main technological process is carried out [9]. In this regard, the question of an informative analysis of non-trivial results of the study of the dynamics of contact interactions between particles of disperse phases, processes of structure formation and disruption of dispersions under dynamic conditions is practically significant for optimizing the technology of composites. In this view, a number of questions related to various aspects of the structure formation of dispersions in dynamic conditions are considered, with the use of modern concepts of the evolution of disperse structures, considering them as the realization of a particular variety of a limited number of laws for the development of complex systems of any nature.

2. ANOMALY RHEOLOGICAL BEHAVIOR OF THE DISPERSE SYSTEMS AND MATERIALS

As indicated in [8–10], the production of dense, strong and durable composite materials is largely determined by the conditions for the formation of the structure upon mixing. The overriding importance of mixing in comparison with other technological processes is regulated by the fact that the basics of the future structure are laid already in the course of the mutual distribution of the constituent components during shear deformation due to rotation of the machine's mixing organs. Description of the behavior of most disperse systems during mixing, as well as in a variety of chemical-technological processes carried out during forced convective diffusion of disperse phases, consists in constructing a complete rheological process curve. Since shear deformation occurs during mixing, the behavior of the disperse system in the gap between the coaxial cylinders of the rotational viscometer may to some extent simulate this operation. Such curves, obtained with the help of rotational viscometers, show the dependence of the effective shear viscosity η on the deformation rate gradient $\dot{\epsilon}$ or the shear stress P with the obligatory realization of the isotropy of the destruction of the system located in the

measuring cell. Under such conditions, a shear with a given intensity extends over the entire gap («pure homogeneous shear» under Rebinder), which determines the isotropic character of the structure breakdown. In accordance with the known classification proposed by Bartenev and Ermilova [3], the existence of the flow curves of two types is typical of structured disperse systems. A single-valued dependence of viscosity and the shear rate gradient on stress is typical of fairly well-studied flow curves of type I. For less studied type II curves, one observes regions of viscosity variation or the rate of deformation development corresponding to an ambiguous change in stress, that is, a drop of P in a certain range of $\dot{\epsilon}$ values. Such an anomalous effect is manifested in the S -shaped flow curves. Rebinder *et al.* [1] obtained the S -shaped flow curves for some clay suspensions that were investigated by Bartenev and Ermilova [2] and explained in terms of the proposed molecular-kinetic theory of a non-Newtonian flow (Fig. 1).

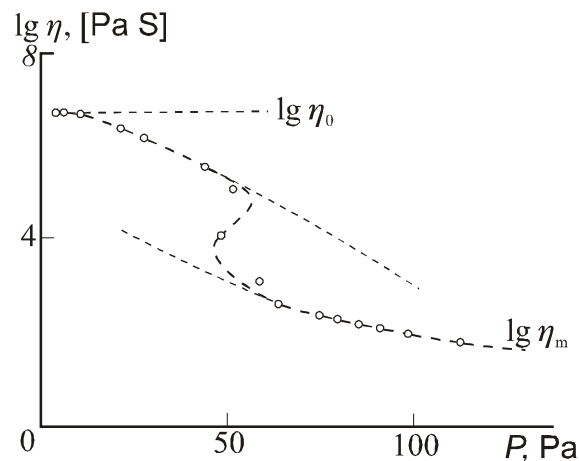

Figure 1: Dependence of logarithm of viscosity η from shear stress P for 10% suspension of Na-bentonite; η_0 is the highest viscosity of a virtually undestroyed structure, and η_m is the least viscosity of the completely destroyed structure (Bartenev, G.M. and Ermilova, N. V., *Colloid Journal*, 1967, vol. 29, No. 6, p. 775)

It should be noted that compliance with the “pure homogeneous shear” in the general case is violated when a certain critical concentration of elements of microinhomogeneities in the volume of the system is reached and exceeded. The deformation of the systems therewith is accompanied by an irreversible local aperture of continuity. As a result, the shift does not extend over the entire gap, but is realized in a relatively thin layer while maintaining an undisturbed or far less disturbed structure in zones immediately adjacent to the discontinuity surfaces. This effect means a violation of the continuum in changing the linear velocity over the cross section of the gap when the strain rate is exceeded. The anomaly of the shear flow process characterized by the type II curves as a consequence of a local structure discontinuity (i.e., when the shear flow is not distributed over the system bulk) was presumably for the first time interpreted in [8]. The theory of this phenomenon was elaborated in [10] on the basis of notions about the presence of local structural microinhomogeneities, whose coalescence under the shear conditions determines the nucleation of a macroinhomogeneity; it was also based on the comparison of relaxation times of processes taking place near the discontinuity nucleus during its development. The proposed approach rather accurately describes the main singularity of the $\eta(P)$ curve for concentrated suspensions, namely, the appearance of a «plateau» region associated with the formation of discontinuity at low P values. The discontinuity is experimentally detected from the abrupt drop of shear stress on reaching the critical, for a given system, deformation rate $\dot{\epsilon}_c$ as it increases within a very narrow range. The subsequent increase in P with $\dot{\epsilon}$ reflects the behavior of a system merely in the discontinuity region

rather than throughout its bulk. Thus, the shear deformation of disperse systems in the gap of coaxial cylinders leads to a significant rearrangement of the microstructure with the formation and development of one or several local shear zones, depending on the concentration of the dispersion phase in the dispersion medium. One of the possible factors for the appearance of local slip zones, equivalent to aperture of continuity, is a jump in concentration near the boundary of the macroinhomogeneity formed during deformation. The hypothesis about such a mechanism of destruction in the shear flow was confirmed in [10] by microphotographs of the structure of aqueous dispersions of calcium bentonite. The kind of discontinuity thereby strongly depends on the solid-phase content in the dispersion medium and correlates with the graphically general view of the dependence of the structure strength on the particle concentration. The following variants are possible: true discontinuity under the conditions of liquid-phase deficiency ($\varphi \gg \varphi_{2c}$); the formation of one ($\varphi \geq \varphi_{2c}$) or several ($\varphi \ll \varphi_{2c}$) slip zones at an excess content of the liquid phase with the formation of solid-like layers (φ_{2c} is the second concentration corresponding to the onset of a sharp strengthening of the structure). The appearance of discontinuity and its subsequent development during deformation exclude [8] the shear distribution over the system bulk, which makes it impossible to reach the minimal level of viscosity and the total failure of the structure. Such a phenomenon leads to a misrepresentation of measurement results and, accordingly, to the impossibility of plotting the total flow curve. This is evidenced [10] by the reproducibility of flow curves in the case of downward and upward motion (the presence of hysteresis loops). This effect is most pronounced at $\varphi > \varphi_{2c}$. Thus, under dynamic non-equilibrium conditions, qualitative changes are observed in the behavior of disperse systems with an increasing intensity of external action: the original structure is destroyed, and a new, laminar structure is formed. This phenomenon is reflected in an unusual run of flow curves.

3. MODELING OF SOME FEATURES OF STRUCTURE FORMATION OF THE DISPERSE SYSTEMS AND MATERIALS

To further develop the notions on the laws and mechanism of formation, stability, and destruction of structured dispersions, it is expedient to add [7] to the explanation of their possible anomalous behavior as a specificity of coagulation under dynamic conditions the analysis of the processes in terms of synergetics and the theory of catastrophes taken together. As is known, synergetics deals [4, 5] with the investigation of the processes of self-organization of structures of various nature formed in systems that are far from equilibrium, and the theory of catastrophes describes [6] those threshold situations in which dissipative self-organized structures arise, are maintained, and lose stability. Within the framework of this approach, disperse systems under dynamic conditions are interpreted as self-organized systems whose evolution in space and time is accompanied by the formation of dissipative structures. It should be noted that whole variety of real stepwise changes of states of such systems (their qualitative restructuring) caused by smoothly varying external actions is described by a small finite number of canonical models – catastrophes. Because the catastrophe theory provides a method to simulate some violations of the continuous development of various processes, it was suggested [7] to interpret possible forms of the manifestation of qualitative structural changes in the shear flow as catastrophes. The S-shaped inflections of flow curves (Fig. 1) illustrate the radical changes in the character of the flow of structured disperse systems. Hence, it is assumed that their anomalous run is identical to that of the standard curve of stationary states [4]. This fact permits the existence of three stationary regimes with the same values of some (master) parameter, thereby making hysteresis phenomena possible [5, 6]. The inflection points of the curve correspond to bifurcation parameters, at which the number of stationary states changes in a jumpwise fashion («catastrophically») with a simultaneous change in the type of stability. Moreover, the unstable states in the middle part of the curve are virtually never realized in real

systems. Thus, the features typical of the flow curves II are inherent to the curve of stationary states. It should be noted that this analogy is presumably both apparent and meaningful. In accordance with [3], two stable and one unstable flow regimes are observed (Fig. 1) in some zone of drastic drop of viscosity at the same shear stress. Consequently, it can be assumed that the theoretical *S*-shaped dependence adequately reproduces the real pattern of the loss of the original flow stability and transition to a new stable regime. Such an assumption allows to predict the character of flow curves in the situations where it is difficult to obtain experimental data. In the case of rheological curves on which the region of recovery of stresses is due to the discontinuity [2, 3], this model takes into account the phenomenon of stepwise transition of a deformable system from the state with a practically undestroyed structure to a qualitatively new state with a specific (layered) kind of destruction. The «threshold» stresses at which changes in the shape of rheological curves are noted are considered as bifurcation stresses. The anomalous portion between the bend points corresponds to unrealizable states of the volume isotropic damage of the structure, since a full rheological curve in the region where the effective viscosity changes from η_{max} to η_{min} can only be obtained [10] when «pure homogeneous shear» is realized. The lower part of graphical dependence corresponds to distorted measurement data describing actually only the processes of friction between the layers confined by the slipping surfaces and a possible partial failure of the structure in the zones adjacent to the fracture. In accordance with the experimental data, such an approach allows to interpret the jump on a flow curve as a consequence of the development of macroinhomogeneity, namely, discontinuity, from the microinhomogeneities of dispersion structure under external action [10]. As was shown in [8–10], for some systems, one can obtain the set of flow curves that are characterized by even more pronounced *S*-shaped pattern with increasing concentration of the solid phase. In particular, this tendency is clearly observed in the flow of an aqueous calcium bentonite dispersion. It is proposed [7] to employ the «ruffle» catastrophe for studying the peculiarities of shear flow, since the considered curve of stationary states represents the cross sections of this model at fixed φ values (Fig. 2). The catastrophe of such a type describes the investigated process using one state variable (η or $\dot{\epsilon}$), two master parameters P and φ and represented by a qualitative model (surface) in the 3D space of these generalized coordinates. The most interesting property of a given surface is the presence of two fold lines beginning at the so-called ruffle point B and forming a bifurcation curve (semi-cubic parabola with the tip at point B_I) on the plane of master parameters P, φ . These points correspond [8] to the first critical concentration φ_0 . On reaching the latter, 3D network starts to form, and the anomalies are observed in the flow of disperse system. The stable stationary regimes geometrically correspond to the points on the surface of manifold of the catastrophe «ruffle», that lie on the upper and lower sheets outside the fold curve, whereas the unstable regimes, to the points on the middle sheet inside the fold curve (the region of inaccessibility which may presumably be treated as a zone of unrealizable states of isotropic failure even with increasing intensity of external effects).

Figure following on the next page

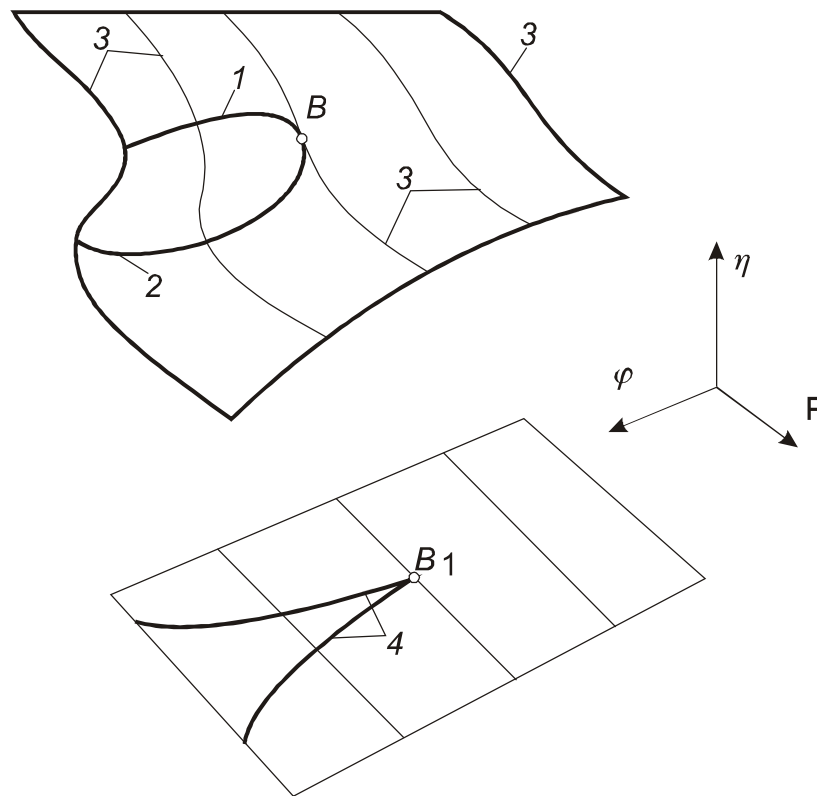

Figure 2: The schematic representation of the dependence of viscosity η of the aqueous calcium bentonite dispersion on shear stress P and the content of dispersed phase φ (the "ruffle" model, the principle of maximal delay); 1 and 2 are fold lines; 3 is the cross sections model; B is the ruffle point; 4 is the bifurcation curve; B_1 is the bifurcation point

Qualitative diversity of the system is determined by various combinations of master parameters. In the considered case, the parameter φ is called splitting parameter, since, on exceeding its critical value, the model surface is splitted up into two sheets, i.e., its variation controls the probability of ambiguity of $\eta(P)$ function and the emergence of jumps. If the condition ($\varphi > \varphi_0$) is fulfilled, then, on varying the second (normal) master parameter P , the right-hand edge of the ruffle is reached. This leads to a jump from one stable stationary flow regime with a virtually undestroyed structure on the upper sheet to another stable stationary regime having local slipping zones on the lower sheet. The fold lines (the right- and left-hand ruffle edges) correspond precisely to those combinations of master parameters that initiate the jumpwise state variations. Such a representation, combining the whole set of possible variants of the aforementioned flow curves in one scheme, is in good agreement [10] with the known experimental results and provides fairly complete information on the qualitative changes in the rheological behavior of disperse systems upon a continuous shear deformation due to discontinuities. It should be noted that in modeling real situations with sudden catastrophic changes of regimes, it is necessary to take into account [5, 6] the presence of two main directions connecting the geometry of catastrophes to the system being investigated (maximal delay and Maxwell principles). The choice of one of the principles is determined by the nature of the phenomenon itself. For instance, in the above-considered case, the first principle is realized according to use it, in particular, in describing and analyzing phenomena associated with the loss of physicochemical stability and hysteresis effects [9, 10]. Hysteresis is [5, 6] one of the basis qualitative features of the ruffle-type catastrophe in the case of using the principle of maximal delay. As mentioned above, structured dispersions away from the thermodynamic equilibrium in the field of external actions are typical synergetic dissipative systems. In the course of their evolution, under dynamic conditions, a considerable reorganization of the

microstructure at a certain critical value of the velocity of shear (parameter corresponding to the bifurcation point) occurs. The initial structure is split into layers (i.e., local volumes bounded by the slip surfaces). Inside these volumes contacts between dispersed-phase particles are not broken and the degree of nonuniformity, which corresponded to the moment of the appearance of the initial (static) structure in the systems, is preserved. A breakage of cross-links, with respect to the flow direction, between the structural elements of the initial cellular-type space mesh and a displacement of the liquid phase from the spacing between particles when the cell boundaries break down are observed. There is a clear tendency for a transformation of the cellular structure to a layer structure, which becomes most pronounced when the solid phase concentration decreases within limits sufficient for self-organization. The cells extend in the shear direction and dissipative layer structures are formed. The development of these structures was preceded [8–10] by a compaction in local volumes of particle microaggregates with a gradual formation of shear planes in the zones of the largest aggregations of packing defects. Thus, at a deformation in disperse system irreversible processes of restructuring caused by the cooperative interaction of defects can proceed [5]. A deformable dispersion with defects (initial local imperfections) displays a behavior which can be represented as an asymmetric bifurcation diagram. In terms of the theory of catastrophes to such an evolution pattern there corresponds the above-mentioned assembly-type catastrophe («ruffle» model). It also seems informative to describe the mechanism of layering of disperse systems as a process of formation of contrast dissipative structures. Since for the existence of such a structure the presence of a set of « activator-inhibitor»-type parameters in the literal sense is not necessary, it is expedient to consider, as a deforming variable, the initial nonuniformity. Consequently, the moment of the appearance of a layering is a precursor of the transition to the accumulation of reversible damages under the action of external force fields. The superposition on a deformable system of a vibration with optimum parameters radically changes [8] the character of its destruction in the shear flow. A destruction of compacted layers with an avalanche formation of microaggregates of particles with simultaneous formation of a structure in the form of cells with loosened coagulation contacts is observed, and the slip zones thereby disappear. From the point of synergetics such an effect can be explained [7] by the increase in the degree of nonequilibrium of the system under an additional action of the vibration, as a result of which the structure is shredded, as a rule. This interpretation is in qualitative agreement with experimental results: a combination of a continuous shear with an oscillation orthogonally directed to it causes [8–10] the structure to break down into aggregates whose size decreases and whose number increases with increasing vibration intensity $I = a^2 \omega^3$ (a is the oscillation amplitude and ω is the circular frequency). It is assumed that the «ruffle» model, located as indicated in Fig. 3, clearly illustrates the peculiarities of structural changes in disperse systems with increasing I that are manifested in the reconstruction of flow curves.

Figure following on the next page

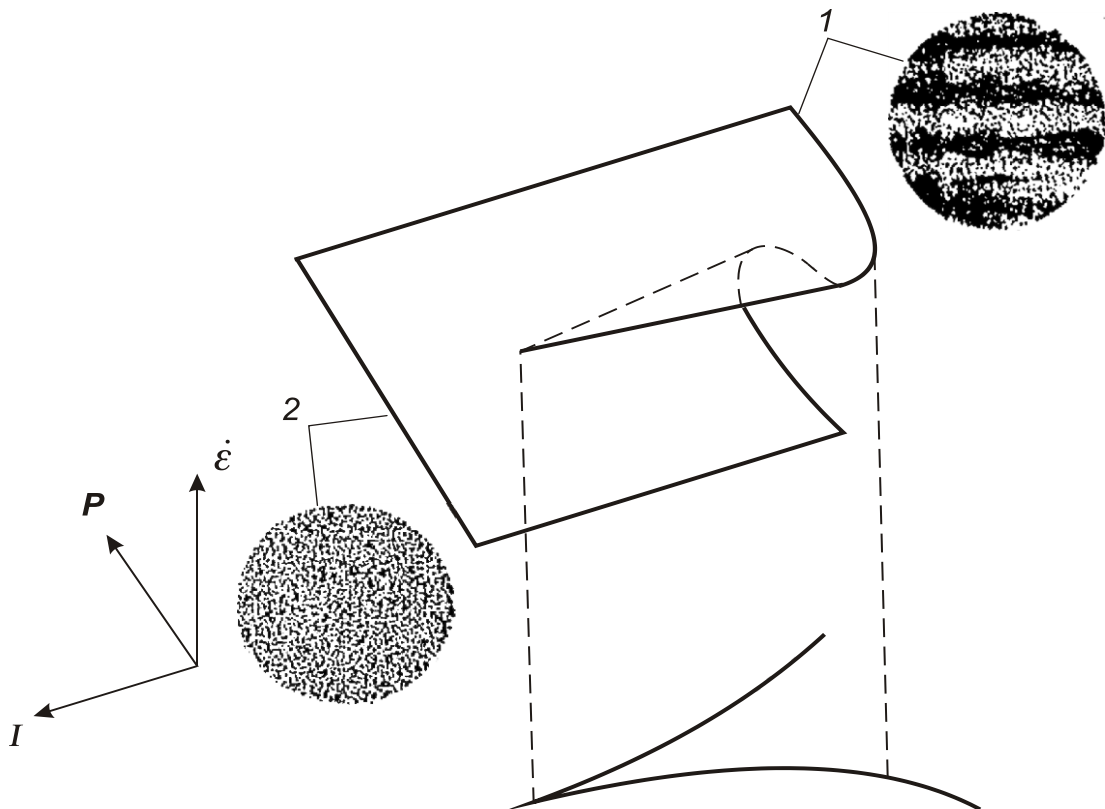

Figure 3: The transformation of flow curves $\dot{\varepsilon}(P)$ with increasing vibration intensity I upon the orthogonal oscillation (the «ruffle» model); the rheological dependences and corresponding dispersion structures: (1) without vibration and (2) during the vibration with optimal parameters

To this day, there is a large volume collected of the results of experimental studies on structure changes in various dispersions serving as base for production of most construction materials. The analysis of collected information revealed that there is an entire category of stick-slip phenomena, the case history of which is represented by S-type inflections on rheological, kinetic and other curves. We must also note that besides S-types there is a range of other characteristics ("flags") pointing to applicability of the methods of catastrophe theory to studying certain processes initiating the apparition of interruptions in system development.

4. CONCLUSION

The main component of physicochemical dynamics is the dynamics of contact interactions between particles, which determines the patterns of destruction and the mechanism of formation, stability of structures in disperse systems under dynamic conditions. Since building composites may be interpreted as self-organizing systems, the evolution of which in space and time is accompanied by the formation of dissipative structures, it is advisable to add the establishment of these patterns with the accepted instrumental methods of research with their description from a single point of view and in a single topological scheme. Thus, raptures of the continuity of the developing processes of various types may be represented in the form of standard catastrophes, which are consistent with the models of dissipative structures. This fact testifies to the stability of topological models of the «fold» and «ruffle» type, (ie, to the suitability for describing real systems). The identification of clearly distinguishable geometric structures in the experimental graphical dependencies allows for the conclusion on the general nature of the phenomena under consideration.

In addition, an understanding of the qualitative aspect of the non-trivial effects found provides an important starting point for further studies of dispersion in critical production situations that arise when composites are made on their basis. For the further development of ideas about the regularities and mechanism of formation, stability and destruction of the above dispersions, it is expedient to supplement the modeling of the processes of structure formation, based on the idea of qualitative leaps in the behavior of the object, with the assumption of a possible soft character of the bifurcation. This approach will allow to expand the range of tasks related to the optimization of the system operation modes in heterogeneous technological processes of generating a variety of building composites.

LITERATURE:

1. Abduragimova, L.A., Rebinder, P.A. and Serb-Serbina, N.N. (1955). Resiliently-viscous Properties of Thixotropic Structures are in the Water Suspensions of Bentonite Clays. *Colloid Journal*, vol. 17, No. 3, pp. 184–195.
2. Bartenev, G.M. and Ermilova, N.V. (1967). On the Theory of Rheological Properties of Solid-like Disperse Structures. Two Mechanisms of Viscous Flow. *Colloid Journal*, Vol.29, No.6, pp.771–778.
3. Bartenev, G.M. and Ermilova, N.V. (1969). On the Theory of Rheological Properties of Solid-like Disperse Structures. Two Types of Rheological Flow Curves. *Colloid Journal*, Vol.31, No.2, pp.169–175.
4. Glansdoff, P. and Prigogine, I. (1973). *Thermodynamic Theory of Structure, Stability, and Fluctuations*. (Vladychenko, N.V. and Onishchukm, V.A. Trans). Moscow: Mir.
5. Nicolis, G. and Prigogine, I. (1990). *Exploring Complexity*. (Pastushenko, V.F. Trans). Moscow: Mir.
6. Poston, T. and Stewart, I. (1980). *Catastrophe Theory and Its Applications*. (Chernavskii, A.V. Trans). Moscow: Mir.
7. Trofimova, L.E. and Uriev, N.B. (2011). *Modelling of Structure Formation of Disperse Systems and Materials*. Odessa: Astroprint.
8. Uriev, N.B. (1980). *Highly Concentrated Disperse Systems*. Moscow: Khimiya.
9. Uriev, N.B. (2013). *Physicochemical Dynamics of Disperse Systems and Materials*. Moscow: Intellect.
10. Uriev, N.B. (1988). *Physicochemical Fundamentals of the Technology of Disperse Systems and Materials*. Moscow: Khimiya.

WRITTEN COMMUNICATION OF A LARGE ORGANIZATION WITH INSTITUTIONAL CUSTOMERS

Grazyna Rosa

*University of Szczecin, Faculty of Management and Economics of Services, Poland
grazyna.rosa@wzieu.pl*

Izabela Ostrowska

*University of Szczecin, Faculty of Management and Economics of Services, Poland
izabela.ostrowska@wzieu.pl*

Leszek Gracz

*University of Szczecin, Faculty of Management and Economics of Services, Poland
leszek.gracz@wzieu.pl*

Kamila Slupinska

*University of Szczecin, Faculty of Management and Economics of Services, Poland
kamila.slupinska@wzieu.pl*

ABSTRACT

Efficient written communication, in accordance to the highest standards in this area, is a very important element of building relations of a large organization with clients. It refers particularly to the mail merge communication. In this context large companies identify the need of a deeper analysis of purchasing behavior of consumers, their preferences and ways of perceiving and understanding written letters. Institutional customers have different expectations, less time, other habits than individual customers. The objective of the paper is to identify and adapt key elements of written communication of a large company with institutional clients to their preferences. The paper reviews the available literature about B2B communication and contains the results of a qualitative research conducted by the authors in a cooperation with a large energy company in Poland. As the result, the paper indicates the universal principles of constructing written communications for institutional consumers.

Keywords: *Qualitative research, Institutional consumers, Written communication*

1. INTRODUCTION

Contemporary business-to-business (B2B) industry markets are characterized primarily by the presence of highly qualified clients, making rational decisions on a strongly competitive global market. Operating companies and institutions should now more than ever should direct a unified and professional message to their recipients. The style of communication chosen should be consistently applied. Lack of discipline and uniform standards means that the messages sent by individuals from the organization are not consistent with each other. It does not build a professional image and a strong brand. Managers note the growing impact of effective communication on customer relationships and profits. In recent years, the communication model and its place in business processes have changed. Companies work in design or in matrix structures. Employees have a more flexible range of responsibilities. The manager has more to do when it comes to effective people management - they must clearly define tasks, delegate them, motivate or build the team's position in the organization. They cannot always do it in person, and the written form requires specific skills. Written communication is an important element of business process management. Its aim is to influence the recipients, convince them to their own point of view or trigger a specific action (Padzik-Wołos, 2015). The analysis of written documentation must be clearly embedded within the context in which it is written:

successful inference is based on this premise (Clarke, 1999, p. 112). Such demanding business circumstances force the definition of corporate communication procedures and standards be in line with the concept and identity of the brand. All types of communication in the company and with clients should be characterized by visible professionalism, but they should reflect the company's values and create the desired company image. From the point of view of effective communication, it is important to shape the message so that it is properly understood, to determine what permanent elements such correspondence should contain and how to plan the writing visually. For this reason, qualitative research was carried out in cooperation with a Polish large energy company (electricity seller, one of the five largest energy sellers in Poland). The energy company, which has about 2 million customers, sends thousands of letters every day, and every employee dealing in written correspondence responds to dozens of customer inquiries. This makes it necessary to use ready-made response templates that employees can further modify. It is important that these templates are professionally prepared, easy to personalize and, above all, adapted to the changing expectations of customers. This article is the third publication in the series devoted to written communication. The purpose of the article is to identify key elements of written communication and to adapt them to the preferences of institutional clients. Consumer segments were distinguished in the research to examine their preferences and find out what different expectations have different customer groups. The article will analyze the results of the survey on institutional clients. In addition, the study included an analysis of the behavior of two segments of the individual clients market, broken down into young and mature clients (see research methodology), and their results will be presented in separate publications.

2. SPECIFIC NATURE OF WRITTEN COMMUNICATION IN B2B RELATION

Written communication in B2B is the subject of analyzes carried out by only a few researchers. Yet, efficient written communications have become increasingly important to public and private sectors managers faced with reading an ever-increasing number of documents (Suchan, Colucci, 1989, p. 454). In the literature, written communication is often considered as a part of formal communication. According to Daft and Lengel (1984), formal communication primarily involves text-based letters and documents, while informal communication involves F2F meetings. Formal communication is essential to carrying out established routines while informal is necessary for developing these routines (Murphy, Sashi, 2018). Formal communication are transmitted in structure traceable and verifiable settings, which may induce stronger perceptions of source credibility, security in interactions and attenuate ambiguity in information transmission. Moreover, since formal communication is essential for routine transactions and coordination activities formality impacts receiver's perception of quality of communication as well as their satisfaction with it (Hossain, Chonko, 2018). The importance of communication is recognized in literature on B2B marketing and is often associated with building relations. In fact, communication is one of the most effective relationship building strategies and a key determinant of outcomes in business-to-business (B2B) relationships (Murphy, Sashi, 2018). However few studies have examined the link between written communication and relationship perceptions. Yet understanding the establishment of this link is a necessary precursor for the development of concrete relationship management strategies (Raciti, Dagger, 2010). In mature business-to-business (B2B) markets, relationship maintenance is very important if firms want to increase their market share and profits. Firms have to satisfy customers in each interaction, thereby building stable long-term relationships and preventing customers from switching (Chang, Wang, Chih, Tsai, 2012). An important aspect of building and maintaining customer relationships is the communication that takes place between the service provider and customer. Indeed, communication plays an important role in sustaining customer relationships in so far as relationship marketing is largely about conveying

to the customer how important they are to the service organisation and imparting a sense of closeness and intimacy that binds the relationship (Raciti, Dagger, 2010). The knowledge effect is a tendency of individuals to assume that their own knowledge is shared by others (Hayes, Bajzek, 2008). Within the traditional communications model of encoding, transmitting and decoding of written communications, observant analysis can be made of the text to determine the underlying themes and emphases. This is an advantage because it does not interfere with the communication process and therefore does not affect the results of the communication directly. It is necessary to match the message, vocabulary and form to the circumstances, so as to use this form of expression for the best communication with its addressees [Simerson, Venn, 2010, p. 197]. The analysis of written documentation must be clearly embedded within the context it is written: It should be remembered that the business customer is looking for solutions that will help them: minimize the risk of failure, save time, which they have too little, reduce the workload and finally increase the chances of success. Many entrepreneurs prefer e-mails, Twitter and traditional mail communication in their communication with clients, stressing at the same time that everyone should choose such written communication tools that are suitable for them due to the nature of the operation in B2B (Łodyga, 2014). Levels of satisfaction for leaner methods of information exchange e.g. email, written communication are also fairly high as they allowed informants to deliberate and convey information in a logical manner, without interruption (Mason, Leek, 2012). Suppliers can design and communicate strong value propositions, while customers will participate in the product use or service application, part of the value creation process. Another context is the use of Big Data - establishing methodologies to manage Big Data availability will impulse to close the gap between B2B marketers' challenges and scientific research (Cortez, Johnston, 2017). The essence of the purchasing process in B2B lies primarily in the diversification of decision-makers. While in the case of consumers we can easily create a customer profile and thus customize the offer, in the case of B2B (especially advanced products or services), we deal with completely different decision-making people - from the independent board decisions to building interdisciplinary teams made up of people with completely different needs for the project (Kraus, 2015). B2B communication takes on an entirely new meaning here. Although the term "business" may cover very different target groups - from corporations to large companies to representatives of the SME sector - we must remember that there is always a human being on the other side. It is true that their motivations are slightly different from those that lead a B2C consumer to buy, but their senses function in the same way (Mróz, 2015). It should be remembered that regardless of whether messages are created for an individual or business client, the message goes to a man who, through the company's goals, also pursues their own goals and aspirations, and every day struggles with the problems and challenges posed by their employer and clients (Łodyga, 2014). In the B2B segment, 90% of activities should be focused on educating the recipient and providing them with valuable content, thanks to which they will be able to increase their significance in the organization in which they work. Only 10% of all transfers should be strictly sales messages. And here comes the second issue: very often people to whom we send B2B communication are not decision-makers - for them, in fact, the price is not crucial to make a purchasing decision, and a test period is much better offer as they can see whether they made the best possible choice for their organization (Sala, 2015).

3. RESEARCH METHODOLOGY

The conviction of consumer rationality and domination in his/her thinking of cognitive processes is visible in most publications on consumer behavior (Kaczmarczyk, 1995, Smyczek, Sowa, 2005, Kieźel, 2010, Kieźel, Smyczek 2011, Rudnicki, 2012). B2B consumers are, for a reason, extremely demanding: responsibility that is associated with the choices they make makes them more cautious and avoid risky transactions.

They have the specialist knowledge necessary to properly assess the offer. They are constantly monitoring changes on the market, and the search for the ideal product or service begins with a comprehensive analysis of available solutions. That is why, when talking about business clients, the value of the ability to conduct dialogue with them is often emphasized. The consumer becomes a partner and the fulfillment of their needs is a priority (Sala, 2015). This approach to the purchase process affects the way marketing research is conducted, directing it to the development of qualitative research (Maison, 2015; Tyszka, 2000). The changes observed in classical qualitative research (Merton, 1946) are a consequence of two phenomena: thanks to the findings in psychology of the last 20 years, which were popularized under the name of behavioral economics (Ariely, 2009) and the emergence of new technological solutions that allowed relatively easy collection of data from respondents using the Internet, e.g. bulletin board or analyzes based on information present in the network (discussion groups or social forums), at the same time allowing for careful observation of real feelings and discovering the causes of specific behavior and decisions of people. The presented research was conducted in Szczecin, in the focus workshop in the Service Inter Lab center from 13.06 to 06.07.2017. The authors of this article were responsible for the scenario of the research, selection of respondents and moderation of interviews. The energy company provided sample templates of written communication and participated in adjusting the scenario of the research to the specifics of the industry. People using the services of the energy company, selected in a targeted manner were the respondents. Differentiating criteria included: gender, age, education, as well as the type of customer - individual or business. In the first stage of the study, three focus group interviews (FGI) were conducted - two among individual consumers divided into young people (up to 40 years of age) and mature people (over 40 years) and one of the company's representatives. During the second stage of the study, i.e. the verification stage, two research groups were accepted - individual persons and corporate customers. Each group interview (FGI) was attended by 7-8 participants, this is the optimal number due to the duration of the study and possibility of an effective examination. The objectives of the focus studies and individual interviews were as follows:

Objective 1: Analysis of customer behavior and preferences regarding written communication.

Objective 2: Analysis of the current state of written communication in visual terms.

Objective 3: Analysis of selected elements of the written message in terms of its affordability.

The written communication presented during the research included, for example, personalized letters based on templates provided by the energy company and which concerned the most common cases of correspondence with consumers.

4. DESCRIPTION OF THE CONCLUSIONS

4.1. General expectations on communication

4.1.1. Evaluation of the company and the way of communication

For customers, it is important to be able to quickly and efficiently settle matters in the energy company being examined, which in their opinion, despite the large number of customers, operates efficiently. The respondents noted the large and free parking at the company's headquarters, which is positively evaluated and significantly affects the image of a partner in business. What makes cooperation difficult is the complexity of charging service fees (many components of the invoice: subscription fee, fixed network charge, variable network charge) and extended procedures (for example connection to the network).

4.1.2. Frequency and understanding of the message

In the case of companies, correspondence is much more frequent than in the case of individual clients. The most frequently discussed topics in correspondence with an energy company are

letters from customers about the change of address, the ordering of new services or complaints about services provided. On the part of the energy company, most often invoices are sent for services rendered together with standard letters, tariff changes or information letters. In most cases, the letters are understandable, but some of them are written in a more difficult language, which according to the respondents, for the average client, it could be difficult to learn. It is true that ultimately the writings are understandable, but you have to focus on them a lot and read them several times to make everything clear.

4.1.3. Electronic form of correspondence

Electronic correspondence is preferred by entrepreneurs, they willingly use this form of communication, as it improves communication. Using this form of communication between companies, according to the participants, allows for better time management. "We decide when we pick it up, it does not interfere with our schedule of the day and we do not have to wait for the helpline to find out something." In this kind of correspondence, however, all the facilities for customers should be used. For example, an e-mail with an invoice attached, the content should contain short information about the amount to be paid, payment date and a link to the online payment form. The subjects were presented with an example of an e-mail from an energy company in the upper part of which was placed an advertisement encouraging the use of e-BOK (Electronic Service Office). According to the people surveyed, the pictures with the advertisement are too big, they do not always open and then there is empty space in the content, which does not look professional. The question of whether such an e-mail could be treated as an advertisement and deleted, the respondents answered that it is possible. However, in the case of electronic messages, the subject of the message is very important, depending on whether the e-mail with the advertisement is not treated as spam or strictly advertising message. There is a suggestion to place an ad below the actual content of the message so that it does not interfere with the reception of the most important content. The use of SMS communication in a B2B relationship can be problematic. The mobile phone is treated as a private thing and the respondents believed that not everyone wants business correspondence received on a private phone. In many companies, especially small and micro-company, the owners do not have a separate telephone or number to handle business matters. Despite these objections, the respondents are of the opinion that reminders in the form of text messages about the date of invoice payment or reminder in case of missing payment date are helpful.

4.1.4. Contact by electronic service office

In every letter currently sent to clients by the energy company, there is an incentive to contact the Electronic Customer Service Office. Company representatives would prefer this form of communication, as it is convenient and does not require additional costs. However, the experience of entrepreneurs shows that currently this solution does not work, because the issues are dealt with too slowly. Therefore, to speed up the matter, they prefer to send correspondence by traditional letter or e-mail. The invoice's paper form is still more often chosen by the surveyed entrepreneurs, despite the fact that they are aware that their co-operators prefer the electronic version. Representatives of companies expect little incentives to change their habits - for example, a subscription fee discount (PLN 1-5) per month. One of the participants gave the reason for resigning from dealing with e-BOK. The reason was too laconic email information - "We have issued an invoice No. ...". There was no information about the amount, account number, payment date. This resulted in an extension of the payment process, because you have to log in to the website, enter the access password, which extends the payment period. It is worth attaching the invoice to the e-mail in the form of a PDF, because companies and invoices must print it anyway to attach it to financial documents. Otherwise, they have to log in to e-BOK each time, which they think is too cumbersome.

4.1.5. The length of the written communication

The participants of the study first of all turned their attention to legal paragraphs and too large volumes of letters that characterize the letters from the institution. These are the two main elements that disturb them in the letters and make it difficult to understand the message. According to participants, the mistake is that the letters start with paragraphs that cause discouragement and the impression of contact with an impersonal institution. To find the answer to the problem that the client has, you have to read many sentences, which takes too much time. According to the respondents, if the legal paragraphs must appear in the letter, they may be placed at the end of the letter and not as a fragment of the letter. Business clients understood the message of the examples presented to them, but they thought that it would be possible to write the same in a shorter and simpler language, and the most important information for the addressee should be placed at the beginning of the written communication. After reading the presented examples, the respondents believe that it would be possible to include their content in a few sentences. The letters are generally too long and not all formulations are needed. Some of the participants emphasized that they prefer that the writings should be printed bilaterally, then the company can actually boast that it is ecological. At the same time, the respondents expected page numbering, in which case some addressees may overlook the other side of the letter. The surveyed entrepreneurs believed that the page numbers, due to the address data in the footer, could be placed in the upper right-hand corner of the letter.

4.1.6. The appearance of the written communication

The visual aspect of written correspondence is also important for the surveyed entrepreneurs. The spacing between lines should be more compact by using a single leading, but the intervals between individual paragraphs can be larger. Thanks to this, individual parts of the written communication are better distinguished. For some participants it is important that the text be justified, that is, aligned to the right or left side. The respondents prefer that the letter has most important information emphasized through the bold font, e.g. the amount and date of payment, account number or the validity period of the permit.

4.1.7. Construction of sentences

Sentences from which messages are built are too long and complex. You have to be very concentrated to understand them well. It was proposed that the letters should take the form of a short information including 2-3 sentences. Additional, less important aspects may be found under the letter (e.g. legal provisions) or on an additional leaflet. Thanks to this, it would be easier to read the letter and it would take less time.

4.1.8. Explanation of a complicated procedure

The respondents pointed out that in the energy company many procedures are too complicated for consumers, and the way they are explained in the writings is intricate and unreadable. It should be determined step by step what should be done. The respondents suggested the use of pictograms illustrating the various stages. The pictogram plays an important role in communication today, especially with young people who like to use emoticons. By replacing the written word or supplementing it with a graphical element, you can increase the readability of the message. The respondents suggested that instead of expanding the content of the magazine, it could be accompanied by an additional information leaflet showing the successive stages of a complicated but often typical procedure.

4.2. Analysis of standard elements of written communication

4.2.1. Contractor's number

The participants believed that the contractor's number should be placed in writing, because it is used for identification and when referring to the energy supplier.

4.2.2. The phrase "concerns"

Participants agreed on the legitimacy of including this introduction in the content of the letter. They think that it is very helpful in understanding the purpose of correspondence.

4.2.3. Courtesy phrases

The form of courtesy should be kept, as in the previous correspondence of the company "Dear Madam / Dear Sir /", adapted to a specific addressee. The representative of the younger generation of entrepreneurs proposes the phrase "Dear Jan", also other younger representatives of companies confirm that they do not mind this form. However, more mature company representatives believe that it is safer to stay on the official side. In their opinion, some people might feel offended by such straight approach. At the end of the written communication, the respondents suggest a formal phrase "sincerely".

4.2.4. Signature

Most of the respondents did not pay attention to the form of the writer. At the same time, the respondents admitted that they are currently using the formula, that is, writing in the first person plural. Correspondence should be formulated in this way, because the writer represents a large organization. Statements - "we checked, analyzed" increase the credibility of the message. According to the respondents, the letter should contain a signature and contact with the person who is dealing with the case. It would be important to enter the name and surname of the person concerned. Facsimile, if it should appear, is expected to be in black. The majority is of the opinion that it should not be placed, all you need is information about the name and surname of the person sending the letter. The respondents pointed out that there are cases of contact of several people in a particular matter from the company, which confuses the recipients. The respondents are aware that it would be difficult if each client was assigned a person (client's supervisor), but it would be a convenient solution for them. It would be good if a situation that would be difficult for the client, for example imposing a penalty or a negative decision, was indicated by a specific person who would explain all doubts of the client. For this reason, the correspondent should be the person who knows the case.

4.2.5. Legal basis

Citing legal provisions in the letter by the respondents is perceived as frightening and disorienting the recipient, making it difficult to understand the content. Some of the surveyed entrepreneurs expect such information, but it can be included in the form of a footnote in the content and placed at the bottom of the letter. Entrepreneurs are aware that in the correspondence of an energy company, such a recall of regulations is often required by the regulator, but in their opinion it should not interfere with the understanding of the content of the letter.

4.2.6. Contact information

The majority of business representatives believe that if the contact information is already contained in the footer of the letterhead, it does not need to be repeated in the body of the letter. Instead of copying the information in the body of the letter, a contact may be placed to a specific person, providing their name and surname, which may be contacted in a given case.

This information can also be placed at the signature. The respondents believe that the footer with address data is currently the standard closing the letter.

4.2.7. Standard phrases

"Thank you for contacting the company x." This statement is received positively, as an emphasis that the company is open to the customer. "In reply to your letter of ..." This formula is useful in extensive correspondence. For the institutions' contact, the number of the letter should also be recalled. It is an element of electronic document circulation and it is impossible to function without it today.

4.2.8. Advertising of company's products

Representatives of companies do not like the idea of placing an advertisement on the back of a formal letter. The respondents believe that nobody will read it anyway, and the letter loses its rank. It's better when an additional leaflet was inserted into the envelope with the letter.

At the verification stage, changed letters were presented to the respondents, which were adapted to the opinions collected from the respondents in the first stage of the study.

4.2.9. Positively evaluated changes in the letters:

- at the very beginning, the most important information for the client is included,
- the letters are more concise and clear,
- organizing content - aligned text, standardized margins,
- clear separation of individual parts of the written communication,
- shortened sentences were positively perceived and the most important information was selected,
- a clear step-by-step guide to what to do in difficult procedures,
- resignation from technical language,
- contact persons included, thanks to which consumers feel that they are addressed individually.

5. CONCLUSION

Business channels preferred by business clients are e-mail and contact via e-BOK. Representatives of companies participating in the survey believe that letters addressed to them should be specific and definitely shorter than those currently sent by their energy supplier. It is important to explain the "step by step" procedures, avoiding quoting extensive legal provisions. The participants of the study were tasked with arranging the letters from the puzzles, which suited them best in terms of the distribution of fixed elements, which made it possible to match the templates of the letters to their preferences. Entrepreneurs pointed out that they are accustomed to certain formats, taught them during school education, for this reason they proposed a traditional form of the layout of the content of the written communication (from the top of the page):

- letterhead - containing the logo on top left,
- unified date format (place, day.month.year),
- complete customer data together with the number,
- an explanation of what the letter concerns,
- welcome phrase,
- the content of the written communication,
- farewell phrase,
- legal aspect at the end in the form of links,

- attachments,
- contacts as a footer in a letter (letterhead: all contact details for the company).

This arrangement results from the traditional formal writing layout. The surveyed entrepreneurs also paid attention to the aesthetics of the written communication, so that they look carefully and were the hallmark of the company (justified text, unified margins). Business customers more often than individual clients apply for additional services or changes in contracts, hence correspondence with media suppliers is more frequent. Understanding the content of most of the exemplary letters from an energy company was not difficult for them. However, they also think that it would be worthwhile to shorten the letters and simplify them so that they would not have to spend much time reading them. Many business managers forget that these are people that create a company and that they communicate with the environment. A well-informed team, familiar with the principles of communication, adequately represents the company outside communicating in accordance with accepted standards. If the members of the organization are able to communicate effectively with each other and with the environment, their competences build the company's strength. In the era of B2B communication dominated by electronic communication or traditional mail, written communication skills should be included in the list of competitive advantages of the company or at least as a strength in the SWOT analysis.

LITERATURE:

1. Ariely, D. (2009). *Potęga irracjonalności*. Wrocław: Wydawnictwo Dolnośląskie.
2. Chang, S.-H et al. (2012), Building customer commitment in business-to-business markets. *Industrial Marketing Management* 41 (2012), pp. 940–950.
3. Mason K., Leek S., Communication practices in a business relationship: Creating, relating and adapting communication artifacts through time, *Industrial Marketing Management* 41 (2012) pp. 319–332.
4. Hayes, J.R., Bajzek, D., (2008). Understanding and Reducing the Knowledge Effect: Implications for Writers. *Written Communication*, Vol 25, Issue 1.
5. Hossain, M.T., Chonko L.B. (2018), Relational communication and illusionary loyalty: Moderating role of selfconstrual. *Industrial Marketing Management* 69, pp. 221–234.
6. Clarke, G. (1999). Evaluation of written communication: a replication study to determine accuracy. *Corporate Communications*. Bradford Vol. 4, Iss. 3, p. 112-120.
7. Cortez, R.M., Johnston, W.J.: The future of B2B marketing theory: A historical and prospective analysis, *Industrial Marketing Management* 66 (2017), pp. 90–102.
8. Murphy M., Sashi C.M., Communication, interactivity, and satisfaction in B2B relationships, *Industrial Marketing Management* 68 (2018) pp. 1–12.
9. Daft, R. L., & Lengel, R. H. (1984). Information richness: A new approach to managerial behavior and organization design. In L. L. Cummings, & B. M. Staw (Vol. Eds.), *Research in organizational behavior*, Vol. 6,) Homewood, IL: JAI Press, pp. 191–233.
10. Kaczmarczyk, S. (1995). *Badania marketingowe. Metody i techniki*, Warszawa: PWE.
11. Kieźel, E. (2010), *Konsument i jego zachowania na rynku europejskim*, Warszawa: PWE..
12. Kieźel, E., Smyczek, S. (ed.) (2011). *Zachowania polskich konsumentów w warunkach kryzysu gospodarczego*. Warszawa: Placet.
13. Kraus, M. (2015). *Jak dotrzeć do klientów z segmentu B2B?*, Retrieved 12.05.2018 from
14. <https://premium-consulting.pl/blog/3-narzedzia-komunikacji-b2b/>.
15. Levick, R. S., „Why B2B Companies Need to up Their Communications Game”.
16. Łodyga, M. (2014). *Jakie 3 narzędzia komunikacji B2B zabralby ze sobą na bezludną wyspę dobry marketingowiec?* Retrieved 12.05.2018 from <https://premium-consulting.pl/blog/3-narzedzia-komunikacji-b2b/>.

17. Maison, D. (2015). *Nowe podejście do badań jakościowych jako konsekwencja zmian w rozumieniu zachowań konsumenta*. (in:) Dąbrowska A., Wódkowski A. (ed.), *Badania marketingowe. Praktyka nauczanie – Nauka praktyce*, Warszawa: IBRKiK.
18. Merton, R. K. (1946). The focussed interview. *American Journal of Sociology*, No 51.
19. Mróz, R. (2015). Jak dotrzeć do klientów z segmentu B2B?, Retrieved 12.05.2018 from <https://marketerplus.pl/teksty/artykuly/dotrzec-klientow-segmentu-b2b/>
20. Padzik-Wołos, A. (2015) *Komunikacja pisemna – lokomotywa czy hamulec biznesu?* Retrieved 12.05.2018 from <http://psychologiasprzedazy.biz/komunikacja-pisemna-lokomotywa-czy-hamulec-biznesu/>.
21. Raciti, M.M., Dagger, T.S. (2010). Embedding relationship cues in written communication, *Journal of Services Marketing* 24/2.
22. Rudnicki, L. (2012). *Zachowanie konsumentów na rynku*. Warszawa: PWE.
23. Sala, P. (2015). *Jak dotrzeć do klientów z segmentu B2B?*, Retrieved 12.05.2018 from <https://marketerplus.pl/teksty/artykuly/dotrzec-klientow-segmentu-b2b/>.
24. Simerson, B.K., Venn, M.L. (2010). *Menedżer jako lider*. Warszawa: Oficyna a Wolters Kluwer business.
25. Smyczek, S., Sowa, I., (2005). *Konsument na rynku. Zachowania, modele, aplikacje*. Warszawa: Difin.
26. Suchan, J., Colucci, R. (1989), An analysis of communication efficiency between high-impact and bureaucratic written communication. *Management Communication Quarterly*, MxQ, May 1989, 2; 4; pp. 454-484
27. Tyszka, T. (2000). *Psychologia ekonomiczna*, (w:) Strelau J. (red.), *Psychologia. Podręcznik akademicki*. Gdańsk: Gdańskie Wydawnictwo Psychologiczne.

IMPACT OF IMPLEMENTED CLOUD TECHNOLOGY ON THE STRUCTURE CENTRALIZATION AND FORMALIZATION IN MANUFACTURING COMPANIES – RESEARCH RESULTS

Magdalena Zalewska-Turzynska

University of Lodz, Poland

magdalena.zalewska@uni.lodz.pl

ABSTRACT

Implementing cloud solutions – as a method to upgrade the adjustment of the company to the widely understood stakeholders' and environment needs – to the company's every-day work probably affects the centralization and formalization of IT department, but the question arises if it affects also the whole company structure – especially its centralization and formalization. The purpose of this study is to verify whether the introduction of the cloud technology solutions to the manufacturing companies affects the centralization and formalization of the organizational structure of the companies. The research method used was the survey (CATI). The study was conducted on a sample of 400 Polish production companies. The targeted choice sample consisted of the micro, small, medium and large firms that use cloud technology either for communication or for core processes. Implementation of the clouds into production companies did not affect the centralization of 79.5% of researched companies, the centralization increased in 10.5% of companies and decreased in 10% of them. Moreover, implementation of the cloud into production companies did not affect the formalization of 69.5% of researched companies, formalization increased in 20.5% of companies and decreased in 10% of them. Exact data have been included in the study.

Keywords: *centralization, clouds, formalization, organization structure*

1. INTRODUCTION

Organizations constantly need to adjust to their environment (Beer, Nohria, 2000, pp. 88-95). One of the possible tools that help to keep up with the widely defined business environment (stakeholders) is the use of a new technology – cloud computing solution. The absorbance of cloud solutions may confirm its importance – 60% of small and medium enterprises have purchased at least one cloud service, and 30% have purchased five or more cloud services (Avrane-Chopard, Bourgault, Dubey, Moodley, 2014). Over 90% of global enterprises report using cloud computing in some part of their business (Right Scale 2015). According to the study conducted on nearly 600 manufacturing enterprises from 17 countries by the market research firm IDC, manufacturers expected to increase the cloud-services share of their annual IT budgets by 27 percent from 2015 to 2017 (Edwards, 2015). There are also estimations, by which the transition from spending money on traditional IT to cloud services, the so-called “cloud shift”, will grow to more than \$216 billion in 2020 (Gartner Says by 2020). In a narrow way, a cloud computing may be understood as introducing new IT cloud software to customer service – it refers to the “applications, the hardware and software delivered as services over the Internet” (Amazon EC2, 2016). Cloud computing is defined by the National Institute of Standards and Technology as “a model for enabling ubiquitous, convenient, on-demand network access to a shared pool of configurable computing resources (e.g. networks, servers, storage, application, and services) that can be rapidly provisioned and released with minimal management effort or service provider interaction” (Mell, Grance 2011, p. 2). The broader approach seems to be adequate for the aim and scope of this article. The companies where IT activities are the core of the business are, of course, familiar with cloud solutions. The level of cloud solution acquaintance and absorption is unknown in the case of the branch of production companies.

They are interesting as the research sample because it is believed that manufacturing companies tend to concentrate on upgrading mainly their products to catch up with clients' requirements, which is their main concern; the other purposes of technology usage go to the further positions on the priority list (The Definitive Guide... 2017). However, the clouds offer a wide variety of applications also for manufacturing companies. It may be smart factories (The smart...) or ERP systems (Abd Elmonem, Nasr, Geith, 2016) and 3D printing, high-performance computing (HPC), the Internet of Things (IoT) and industrial robots (Ezell, Swanson, 2017, Nandgaonkar, Raut, 2014; Kussul, Shelestov, Skakun, 2011). Clouds, therefore, may be used for communication with the client (e.g. receiving orders, sending orders for raw materials, etc.), but also for gathering, analyzing and storage of client data, employees data, retail and marketing data, contacts, invoices, direct debits, financial organization data, data related to software development or intellectual property. The first purpose is named in this research “the e-mail only”. When that list of possible applications is broadened, it is referred to as “more than e-mails”. If the introduction of clouds to the company is the change like a basic computer program change, concerns the change of the tool – the prediction seems to be valid that the company internal structure would not change. That kind of change requires, of course, some adjustment, perhaps different employees' competencies that may be achieved by additional training or change in the number of hardware units, but altogether it will not affect the organizational structure of the organizations. Unfortunately, some of the private observations of the author led to the question if it is really so. The shift from traditional computing to cloud computing in production companies probably entails some changes inside organization structure. As a consequence, the research question was set up. The purpose of this study is, therefore, to diagnose how the introducing of the cloud solution influences the organizational centralization and formalization in production organization.

2. STRUCTURE CHANGE – CENTRALIZATION AND FORMALIZATION DIMENSIONS

As far as *modus operandi* is concerned, organizations tend to shift towards cloud solutions implementation into businesses in the form of mail-boxes, simple data storage in the cloud, and also in a larger variety of possibilities (Dunbar, Starbuck, 2006), based on core processes of the organization. There exists a large variety of possible shapes of organization. Regardless of the sector (production, trade or service), the organizational design type is measured by some dimensions that fall into structural and contextual types (Marasi, Bennett, Budden, 2018, Albers, Wohlgezogen, Zajac, 2016, Tolbert, Hall, 2009, Pugh, 1973, Pugh, Hickson, Hinings, Turner, 1968). Structural dimensions provide labels to describe the internal characteristics of the organization. They create a basis for measuring and comparing organizations. Contextual dimensions characterize the whole organization, including its size, technology, environment, and goals. Since the contextual dimensions can be confusing as they represent both the organization and the environment, therefore, the internal part was taken into consideration, that is - size and technology. The structural dimensions consist of centralization, formalization, a hierarchy of authority, personnel ratios, professionalism, and specialization (Daft, 2015; Hunter, 2015). Since centralization refers to the hierarchical level of the authority allowing for making a decision, it is measured by the number of decisions (and possible decisions) that are to be made on each of organization levels. Decisions may concern simple or complex issues, like e.g. purchasing equipment, establishing goals, choosing suppliers, setting prices, hiring employees, and deciding on marketing territories. (Marasi, Bennett, Budden, 2018). Formalization is measured by the amount of written documentation in the organization, that is a number of procedures, job descriptions, regulations, written rules, policy manuals, also simply by counting the number of pages of internal documentation within the organization (Toivonen, Rivera-Santos, 2016; Bruhn, McKenzie, 2014).

The dimension of centralization and formalization were chosen for the purpose of this paper because of its limited size.

3. RESEARCH METHOD AND SAMPLE

The research method used was the CATI survey (computer-assisted telephone interviewing). The phone calls were directed to 50 212 companies, the return was from 400 of them, the return rate, therefore, equals 0.7966%. The chosen Polish organizations were targeted based on three criteria – size, sector and condition whether the cloud solution is used in the company's everyday life. The size criterion imposed a choice of minimum 50 organizations from each size group: micro (employing up to 9 persons), small (from 10 to 49 people), medium (50 to 249 employees) and large (employment above 250). Finally, the sample consists of 50 micro-companies (12.50 %), 81 small companies (20.25 %), 146 medium companies (36.50 %) and 123 large enterprises (30.75 %). Only production companies were taken into account. The second and third criteria were simply 'yes' or 'no' answers, in the case of 'no' the company was excluded from the research. Because of the third condition, all companies use clouds for work, but 181 of them only for mailing purposes, 219 use a wider range of possible solutions.

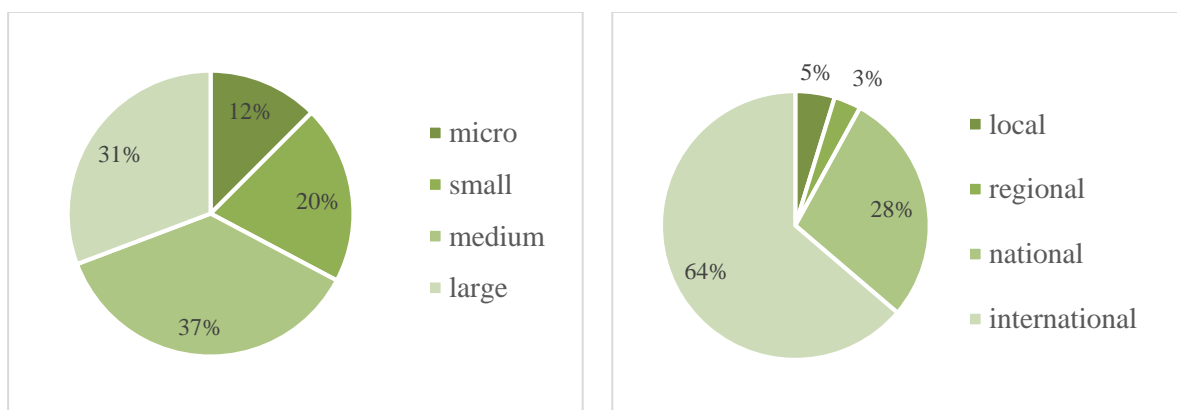

Figure 1: The company's size (left) and the company's market activity (right)

The dominant range of the company's market activity was established in terms of turnover– the sample consists of 4.75% of local companies (area of the county), 3.25% of regional (area of the voivodship), 28.25% of national and 63.75% of international companies, see the picture above.

4. IMPACT OF CLOUDS ON STRUCTURE AND DESIGN – RESEARCH OUTCOMES

In the majority of companies, the centralization and formalization did not change – 79% and 69% respectively did not change these dimensions. The decrease in centralization as well as in formalization occurred in 10% of companies. The increase in centralization happened in 11% of companies, whereas, in formalization, the increase occurred in 21% of them. See Figure 2, below.

Figure following on the next page

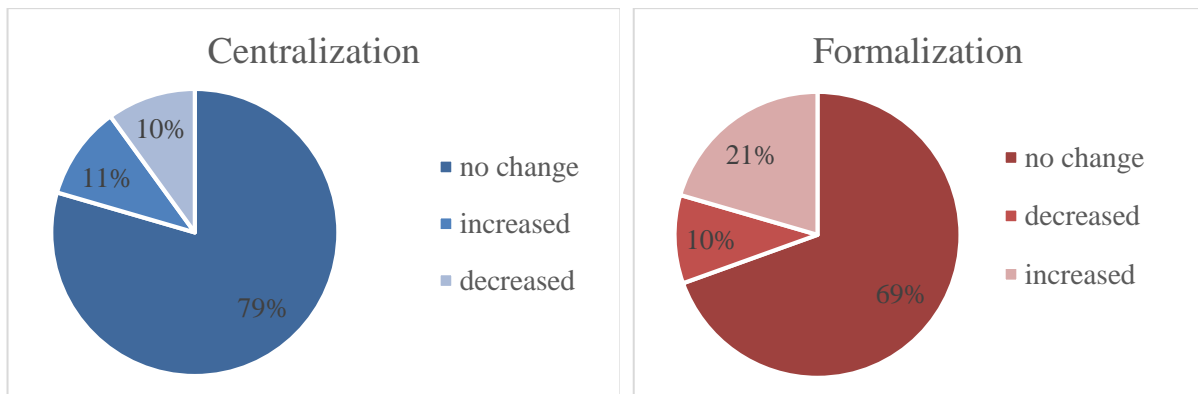
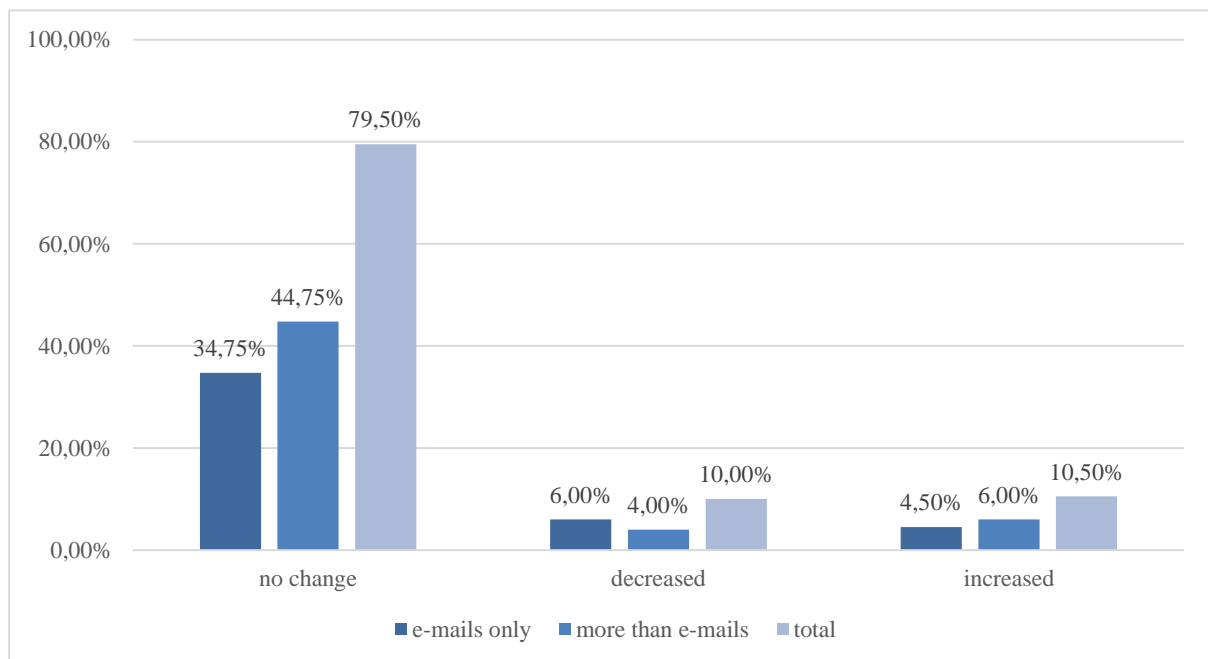

Figure 2: Change in centralization (left) and formalization (right) of companies that implemented cloud solutions (own research)

The statistical values were calculated by the SPSS program. Unfortunately the outcome values are statistically insignificant, the dependence is measured by chi-squared measure and the strength is measured by V-Cramér's, the values are shown below each figure. Nevertheless the outcomes are interesting. As far as the purpose of the cloud solution is concerned, more companies that use clouds for more purposes not only e-mailing faced the increase of centralization – 6.00% than those that use clouds only for e-mailing – 4.50% in the researched sample. Centralization has decreased more in those companies that use clouds for e-mailing only – 6.00% than in those that use clouds for a broader range of purposes – 4.00%. See the picture below. Moreover, fewer companies that use clouds for e-mailing find no change – 34.75% than the companies that use clouds in a large variety of purposes – 44.75%.



$N = 400$; $p = 0.099$; Cramér's $V = 0.099$

Figure 3: Centralization versus the purpose of the cloud

The scope of the companies has an impact on decreasing centralization at most in national scope organizations – 6.00% of all researched companies and has no impact at all for regional companies – 0.00%. The increase of centralization affects at most local scope companies – 3.00% and have the least impact on international companies – 0.75% of all researched companies. It is shown in Figure 4, below.

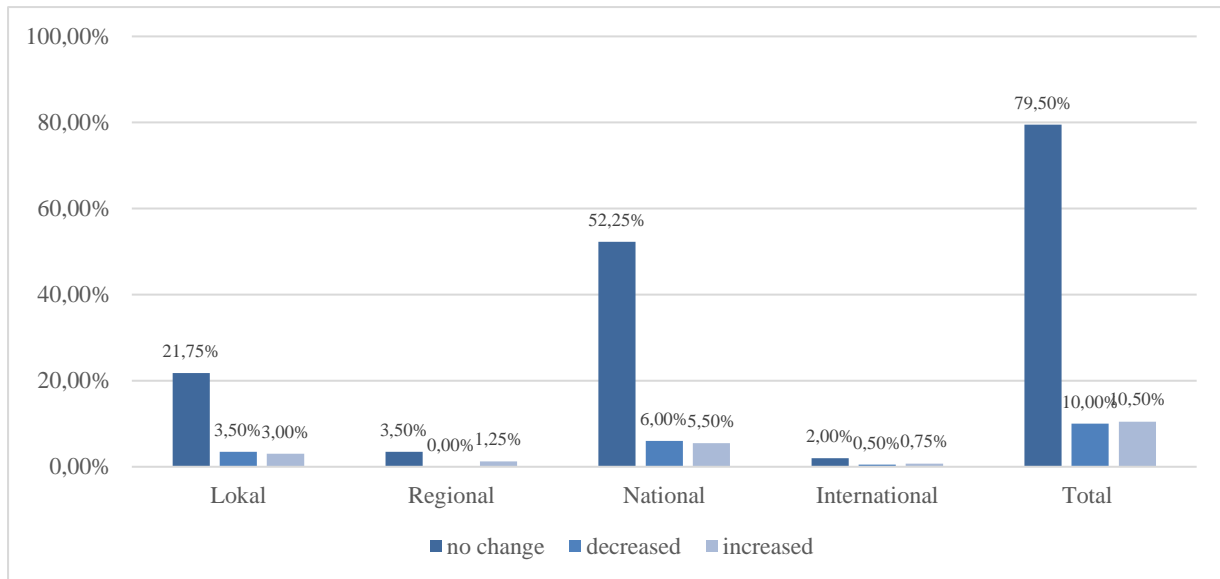

$N = 400; p = 0.168; Cramér's V = 0.119$

Figure 4: Centralization versus the organization scope

Companies of micro size were affected by centralization decrease at most – 3.00%, to a lesser extent – medium companies, that is 1.75% of the total number of researched companies. The centralization increases at most in large companies – 5.75% of all researched companies and the least – in medium companies 1.00% of them, see Figure 5 below.

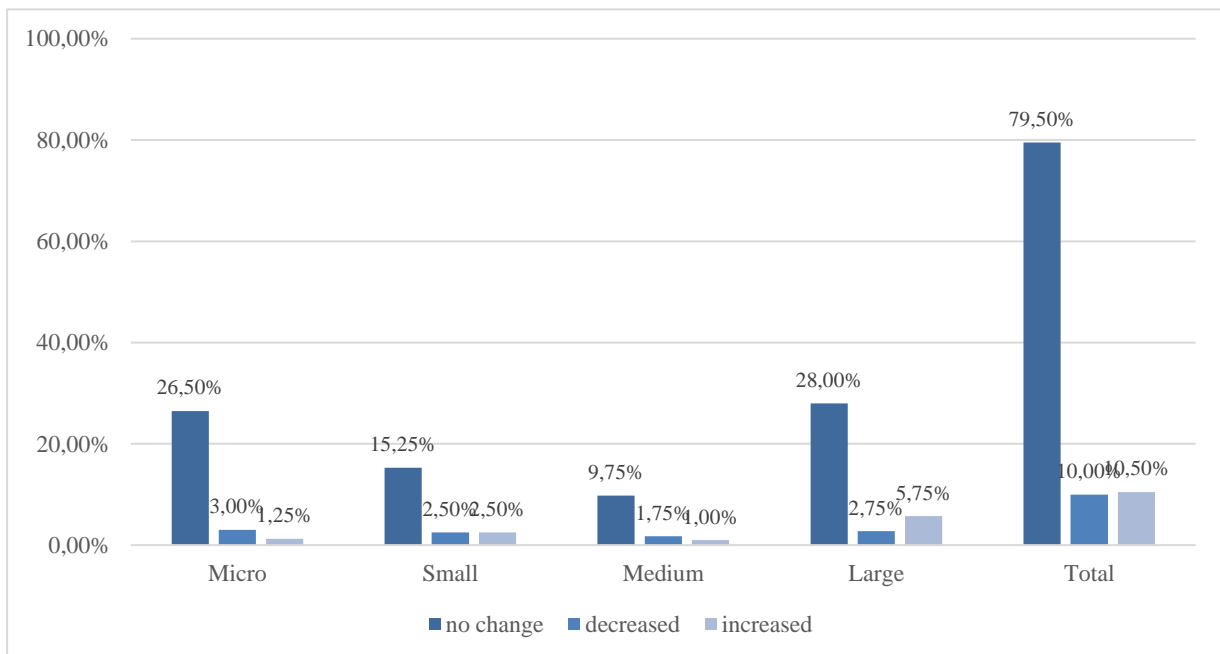

$N = 400; p = 0.176; Cramér's V = 0.125$

Figure 5: Centralization versus company size

The research outcomes concerning the dimension of formalization are presented below. The formalization has changed more in companies that implemented clouds for the purposes wider than only e-mails. The formalization decreases less in companies that use clouds for e-mails only – 3.25%, comparing to companies that use clouds for a wider range of purposes – 6.75%. The formalization increases almost equally in the companies that use clouds for e-mail purposes – 10.00% and companies that use clouds for a wider range of purposes – 10.50%.

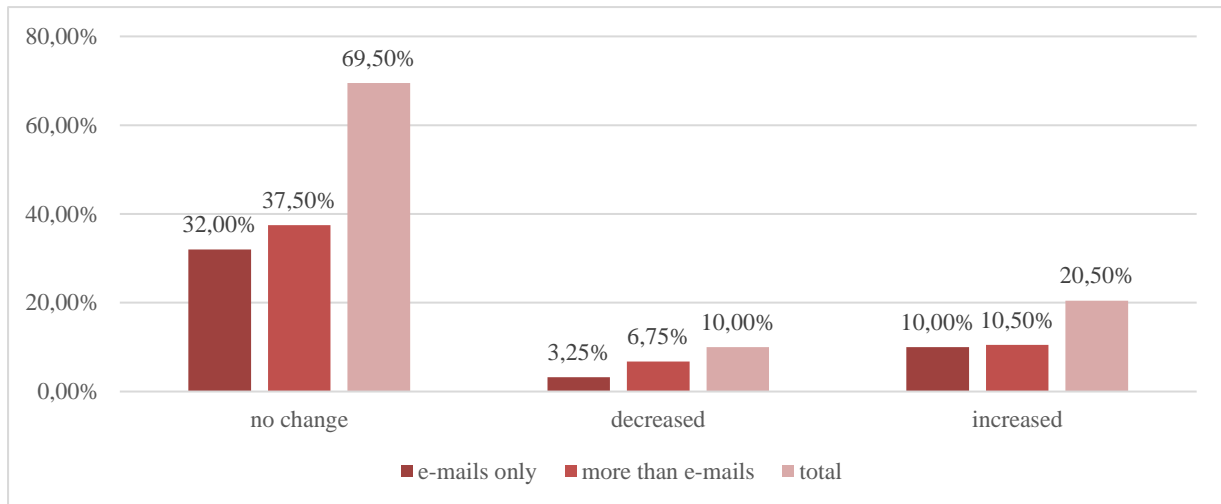

$N = 400$; $p = 0.088$; *Cramér's V* = 0.088

Figure 6: Formalization versus the purpose of the cloud

Formalization has changed mostly in companies of international scope – it decreased in 7.75% and increased in 14.50% of them. The smallest change has been observed in local and regional companies in this order. Formalization has not decreased at all in organizations of local scope and in 0.25% companies of regional scope (below the statistical error). Formalisation decreased in 0.50% organizations of local and regional scope in the researched sample. The detailed percentage is shown in Figure 7 below.

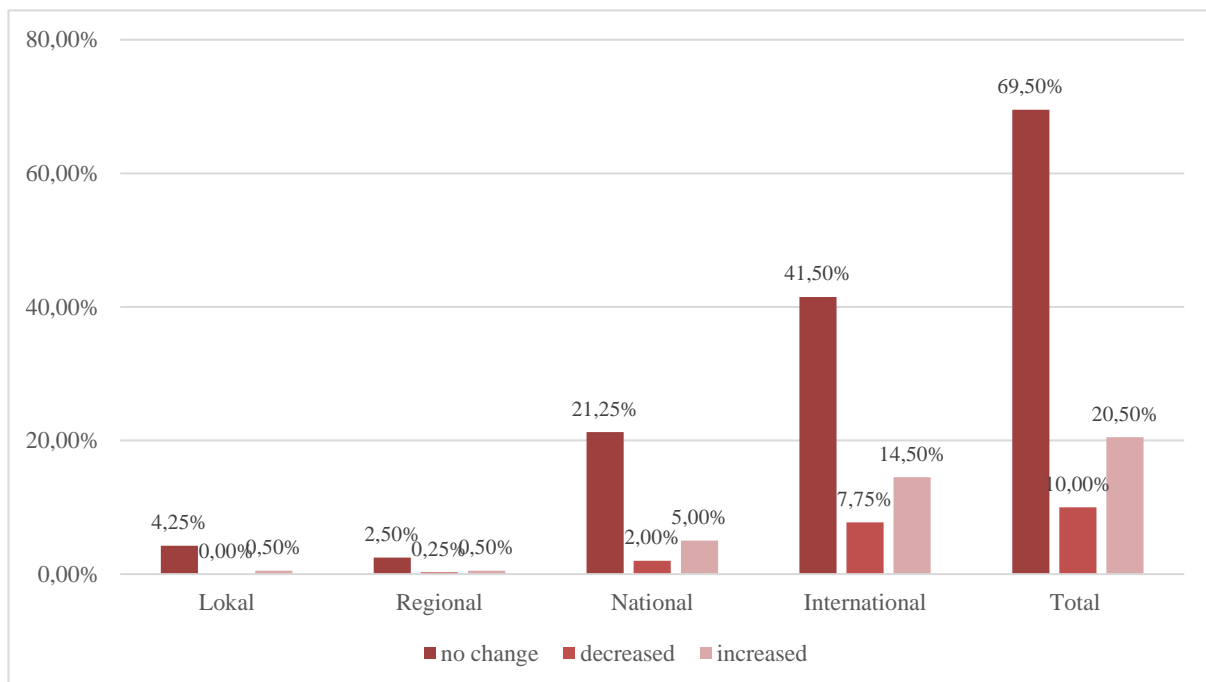

$N = 400$; $p = 0.148$; *Cramér's V* = 0.104

Figure 7: Formalization versus the organization scope

Formalization has decreased at most in medium companies – 5.25% and the least in small and large-sized organizations – 1.50% of researched companies. On the other hand, formalization has increased at most in the medium companies – 7.50% and the least in the micro-sized organizations – 3.00% of researched companies. The detailed outcomes are presented in Figure 8 below.

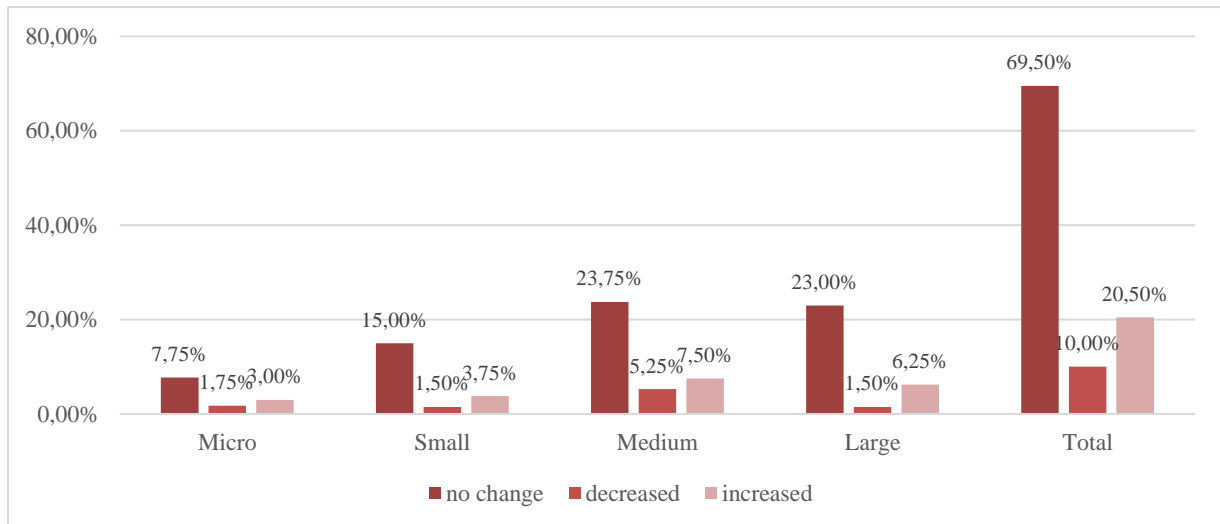

$N = 400$; $p = 0.153$; *Cramér's V* = 0.108
 Figure 8: Formalization versus company size

5. CONSLUSION

There are only 2.50% of companies in which the centralization and formalization increased at the same time. There is also 2.75% of companies in which the centralization and formalization decreased at the same time. There is a significantly large group of companies – 16.00% - in which formalization has increased but there was no change in centralization at the same time. Only 4.75% of companies are in opposite position where the centralization has changed but there was no change in formalization.

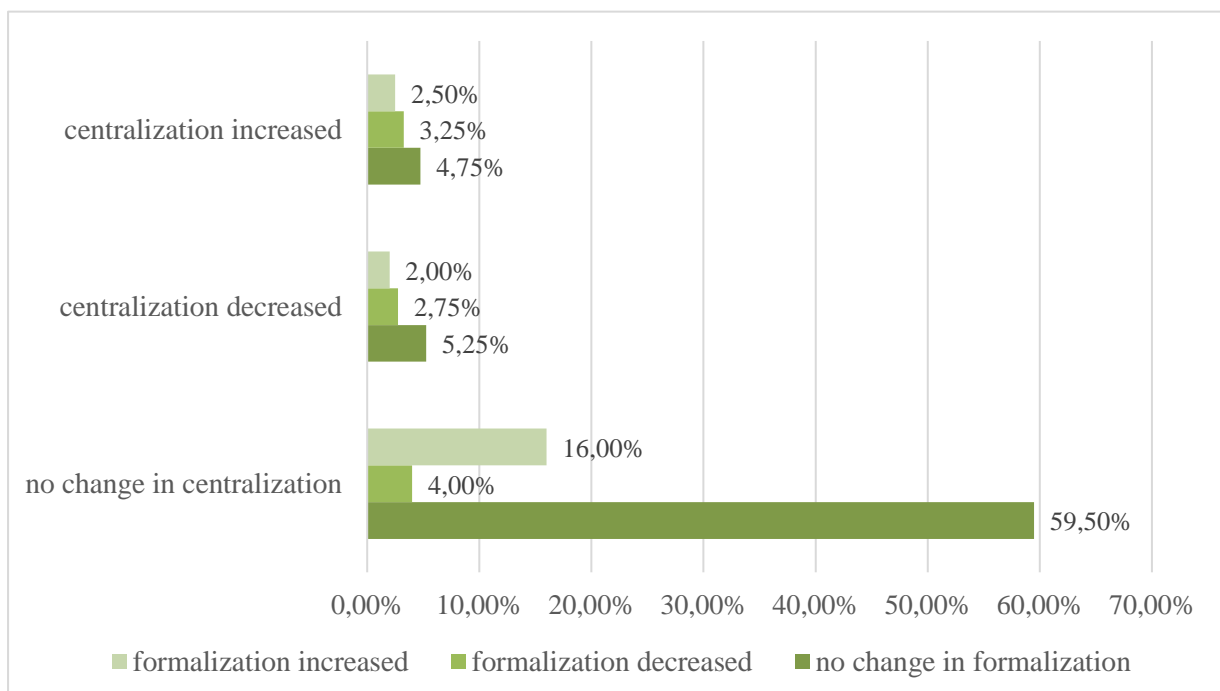

Figure 9: Centralization versus formalization

Moreover, there are 3.25% of companies in which centralization has increased but formalization decreased, and 2.00% of the otherwise situation. To sum up, the 59.50% of researched companies had no changes at all in either centralization or formalization after implementing the cloud solution to every-day organizational activities.

That simultaneously means that 40.50% of companies had changes in the organizational structure (dimensions of centralization and formalization) after implementing clouds. That may lead to the conclusion that introducing clouds is not only a simple change to more modern tools that help to conduct common activities of organizations. If the change in tools affects the organizational structure, it has to bring some changes in the management of the organization. This change requires further research – this is the direction of further, deeper research on the subject.

LITERATURE:

1. Abd Elmonem, M. A., Nasr, E. S., Geith, M. H. (2016). Benefits and challenges of cloud ERP systems – A systematic literature review. *Future Computing and Informatic Journal*. pp. 1-9.
2. Albers, S., Wohlgezogen, F., Zajac, E. J. (2016). Strategic alliance structures: An organization design perspective. *Journal of Management*, 42(3), pp. 582-614.
3. *Amazon EC2*. Online: <https://aws.amazon.com/ec2/>, April 2016.
4. Avrane-Chopard, J., Bourgault, Th., Dubey, A., and Moodley, L. (2014). *Big Business in Small Business Cloud Services for SMBs*. McKinsey Company. available at: https://www.mckinsey.com/~media/mckinsey/dotcom/client_service/high%20tech/pdfs/big_business_in_small_business_cloud%20services_for_smb.ashx [26-03-2018].
5. Bruhn, M., McKenzie, D. (2014). Entry regulation and the formalization of microenterprises in developing countries. *The World Bank Research Observer*, 29(2), pp. 186-201.
6. Daft R. L. (2015). *Organization Theory and Design*, Canada, Cengage Learning, 12th edition, pp. 46-85.
7. Dunbar, R. L. M., Starbuck, W. H. (2006). Learning to Design Organizations and Learning from Designing Them, *Organization Science*, 17(2) (March–April 2006), pp. 171–178.
8. Edwards, J. (2015). IDC Survey: Majority of Manufacturers Use Cloud, *Cloud Solutions News*. April 21, 2015. <https://solutionsreview.com/cloud-platforms/idc-survey-majority-of-manufacturers-use-cloud/> [26-03-2018]
9. Ezell, S., Swanson, B. (2017). How Cloud Computing Enables Modern Manufacturing?, *Information Technology and Innovation Foundation*. June 2017. American Enterprise Institute, pp. 1-33.
10. “Gartner Says by 2020 “Cloud Shift” Will Affect More Than \$1 Trillion in IT Spending,” Gartner, July 20, 2016, <http://www.gartner.com/newsroom/id/3384720>.
11. Hunter, S. D. (2015). If Ever the Twain Shall Meet: Graph Theoretical Dimensions of Formal and Informal Organization Structure. *International Journal of Social Science Studies*, 4(10), October, pp. 79-90.
12. Kussul, N. Shelestov, A., Skakun, S. (2011). *Grid Technologies for Satellite Data Processing and Management Within International Disaster Monitoring Projects* (chapter 14) [in] S. Fiore, G. Aloisio, (red.) “Grid and Cloud Database Management”, Springer-Verlag, Berlin.
13. Marasi, S., Bennett, R. J., Budden, H. (2018). The Structure of an Organization: Does It Influence Workplace Deviance and Its' Dimensions? And to What Extent?. *Journal of Managerial Issues*, 30(1) pp. 8-27
14. Mell, P., Grance, T. (2011). *The NIST Definition of Cloud Computing: Recommendations of the National institute of Standards and Technology*. 1-7, available at: <https://nvlpubs.nist.gov/nistpubs/Legacy/SP/nistspecialpublication800-145.pdf>
15. Nandgaonkar, S. V., Raut, A. B. (2014). A comprehensive study on cloud computing. *International Journal of Computer Science and Mobile Computing*, 3(4), pp. 733-738.

16. Pugh, D. S. (1973). The measurement of organization structures: does context determine form?. *Organizational Dynamics*, 1(4), pp. 19-34.
17. Pugh, D. S., Hickson, D. J., Hinings, C. R., and Turner, C. (1968). Dimensions of organization structure. *Administrative Science Quarterly*, pp. 65-105.
18. State of the Cloud Report 2015, (*Right Scale, 2015*), <http://assets.rightscale.com/uploads/pdfs/RightScale-2015-State-of-the-Cloud-Report.pdf>. [14-05-2018]
19. *The Definitive Guide to Connected Manufacturing*, 2017, Plex Systems.
20. *The smart factory. Responsive, adaptive, connected manufacturing*, “Deloitte University Press” (DUP).
21. Toivonen, A., Rivera-Santos, M. (2016). Facing formalization pressures: Understanding options and choices for informal entrepreneurs. *Academy of Management Proceedings* 2016(1), p. 15442. Briarcliff Manor, NY 10510: Academy of Management.
22. Tolbert, P. S., Hall, R. H. (2009). *Organizations: Structures, Processes, and Outcomes*. London – New York: Routledge, (10th edition), pp. 19-43
https://books.google.pl/books?hl=pl&lr=&id=IsVcCgAAQBAJ&oi=fnd&pg=PP1&dq=Hall,+Organizations:+Structures,+Processes,+and+Outcomes+&ots=hYuN7vp9eK&sig=4MDPTs7KIOemXcJsPi7Wdzt4imc&redir_esc=y#v=onepage&q=Hall%2C%20Organizations%3A%20Structures%2C%20Processes%2C%20and%20Outcomes&f=false

CAPITALIZATION RATE FOR LANDS IN LARGE CITIES OF UKRAINE: APPROACHES TO THE DEFINITION OF SPATIAL HETEROGENEITY

Andrii Martyn

*National University of Life and Environmental Sciences of Ukraine, Ukraine
martyn@nubip.edu.ua*

Anatolii Kolosiuk

*Odessa State Academy of Civil Engineering and Architecture, Ukraine
kolosukaa@gmail.com*

ABSTRACT

The article deals with the concept of "capitalization rate" as a key parameter in assessing the value of urban land. A comparative analysis of definitions and methodological approaches to determining the rate of capitalization of rental income for urban land in accordance with International standards of valuation and national legislation of Ukraine is given. It is shown that the capitalization rate is a key indicator in modeling the estimated value of land, as the results of the assessment tend to show high sensitivity to it. It is proved that the rate of capitalization of rental income for land plots can vary not only in regard to the financial market conditions and the risks of economic activity that are relevant for region or country, but also even within a city territory, reflecting the spatial heterogeneity of the local risks of real estate investments, as well as natural and technogenic risks.

Keywords: *capitalization rate, land valuation, rental income, spatial heterogeneity, urban land value*

1. INTRODUCTION

Historical experience testifies to the clarity of the words of one of the founders of the classical political economy of the second half of the seventeenth century, William Petty, that for humanity "Labor is the Father and active principle of Wealth, as lands are the Mother." Thus, the fundamental development of a given subject in time and space by studying the maternal properties of the land a priori should enrich the knowledge of humanity.

1.1. Development and transformation of forms of land rent during the XVII-XIX centuries

Incompatibility of ownership and ownership of land, as well as a specific form of assignment by the owner (in the non-economic compulsion of the production of products and forcibly removing the results of additional labor of the subordinate workers) of income are characteristic features of the formation of feudal rent. Meanwhile, by not allowing the perception of the land as an object endowed with the decisive properties of capitalized value added and separating the land from the means of production created by man, feudalism itself generates a monetary form of land rent. The monetary form of land rent for a certain moment even provides for the intensive development of the feudal mode of management and finally becomes the basis for the development of additional properties of land rent. The theoretical foundations of modern understanding of land rent, as a special form of capital, began in the second half of the nineteenth century, namely:

- The theory of the British philosopher and political economist John Stuart Mill states that the land, combined with its improvements, is a limited blessing of humanity, which has the ability to form a rent - as "price privilege" [p.173; 9];

- The theory of the German economist, philosopher and political journalist Karl Henry Marx, described in the paper *Capital*, suggests an understanding that "land rent can not be understood without capital" [p.33; 15].

1.2. Development and transformation of land ownership in the nineteenth century

In the capitalist system, the understanding of land ownership was under influence of the development of commerce, and, instead of its traditional perception (as a means of agricultural production), in the nineteenth century, understanding of land as goods and capital becomes widespread. The initial values of goods and capital of this period are based solely on the intuitive and situational understanding of the yield of land (land rent), which stimulated the formation of socially acceptable concepts and meanings. The aforementioned views were proven by the time and at present, the definition of the value characteristics of land as goods and capital has received international infrastructure that provides expert-made professional appraisers with reliable judgments on the value of real estate.

1.3. Rate of capitalization of land rent as a universal indicator of spatial heterogeneity of urban real estate risks

It should be noted that in the most cited studies on the problem of determining the rate of capitalization, it is considered as an interest rate or a return on which capitalized annual net income from an investment to establish its capital value at a given date. This approach is used in studies of Ambrose (1993) [1], Sivitanides (2001) [2], DiPasquale and Wheaton (1996) [3], Evans (1990) [4], Capozza and Helsley (1989) [5], as well as fundamental book of Eckert and Gloudemans (1990) [6]. At the same time, the need to apply spatial analysis, GIS and mapping in the assessment is emphasized by Krause and Bitter (2012) [7], De Groot (2006) [7]. Contemporary land valuation practices of the most significant cities of Ukraine consistently show the characteristic localized differences in the market value of similar adjacent and intermediate land plots within the integral and homogeneous territories of the urban development. Analysis of spatial differences indicates the existence of certain spatial risks associated with the yield of real estate, which caused by the variability of current capital value. Taking into account the objective of research, the yield of real estate in accordance with the requirements of the International Valuation Standards (IVS), achievement of the set goal can be ensured within the income approach, the essence of which is that the market value is provided by transforming future cash flows (revenues) into a single value of the current cost of capital [p. 14; 12]. Accordingly, the only tool for studying the spatial heterogeneity of urban real estate yield risks is the land rent capitalization rate – the universal coefficient, based on the yield of real estate, through which the market value can be determined quickly and simply.

2. LAND RENT, ITS ESSENCE, TYPES AND MECHANISMS OF CREATION IN CITIES

Scientific and practical search and investigation of the late nineteenth century brought economic sense to attract land in the process of capitalist relations not only in the form of goods, but also form of capital (with a number of characteristics and features of market economy object) [15]. At the beginning of the 20th century, the leader of the neoclassical direction in economic science, Alfred Marshall distinguishes three groups of factors of the formation of land rent: the natural fertility of the soil; improvement of land at the expense of investments and factors influencing the location of land (roads, railways, etc.). In this regard, according to the founder of the "Cambridge School" A. Marshall, land rent should not be considered as an isolated category, but as the main form of a long series of phenomena with a specific peculiarity, having the highest theoretical and practical significance [p.356; 11]. The beginning of the XXI century is characterized by the dynamism of the growth of the role of territorial space in social

development, which greatly increased the demand for land in general and on the land of urban agglomerations and cities in particular. These changes are due to the deepening of the view of the territorial space as a complex and variable bio-socio-economic system, endowed with peculiarities of the reverse effect on the choice of social trends, decisions and intensity of the use of territories [p. 6; 10]. The increased demand for urban real estate and the significant limitations of its offer are a classic situation of increasing its value (capitalized rental income from such real estate), which usually activates the attraction of investment capital. Meanwhile, at the beginning of the XXI century, the nature, types and mechanisms of the formation and capitalization of land rent of urban real estate remain poorly researched.

2.1. The essence and types of land rent of urban real estate

In modern western literature, the term "economic rent" is used, which is a broader notion than land rent. In the general sense, economic rent is an additional income that is inelastic on the supply of a resource, created by the alternative to obtaining such income with relatively low investment in the relevant resource (of course, in comparison with the same investment of capital in other resources). With such a definition of economic rent - other types of rent, and in the first place, land rent, serve as varieties of economic rent. High market prices for urban real estate show the development and fullness of all components of rental income: absolute, differential and monopolistic, which provides a better opportunity for research and analytical calculations. It should be noted separately that, in the absence of a country for several decades of economic stability research, the most objective values of the Market value of real estate within a specific limited urban territorial wealth can be determined by studying the types of land rent and the specific mechanisms of its formation solely by the income approach. Thus, based on the classical perception of land rent as a combination of absolute, differential and monopolistic rents, when considering the mechanisms of the formation of land rent of urban real estate should distinguish between all three of its types.

2.2. Mechanisms for the creation of certain types of land rent for urban real estate

The mechanisms of the formation of absolute, differential and monopolistic types of land rent of urban real estate usually differ in the feature of the conditions and factors of their formation, as well as the specifics of sources of additional income (Table 1). Under the absolute land rent of urban real estate should be considered part of the additional income derived from the alternative to investing in urban development. The source of this kind of rent is the monopoly of private ownership of land and relatively higher returns on the development of urban areas than from management in other sectors of the economy.

Table 1: Mechanisms of land rent formation for urban real estate

<i>Type of land rent</i>	<i>Condition</i>	<i>Factors</i>	<i>Specific source</i>
<i>Absolute</i>	Private land ownership and relatively higher returns from urban development than from other sectors of the economy	Private property monopoly	Surplus of additional income over the average indicator of business
<i>Differential</i>	Convenience of the location of the land and additional investment in land improvement	Monopoly on facility	Surplus of additional revenue due to the attractiveness of the location and improvement of real estate
<i>Monopolistic</i>	Limited and outstanding attractiveness of unique fragments of urban development (historical, cultural, natural, recreational, commercial, etc.)	Monopoly on the unique qualities of a limited resource	Surplus of additional income at the expense of redistribution of profits from other branches of economy

Under the differentiated land rent of urban real estate, should be considered part of the additional income received from the location of the land plot and additional investments in its land improvement. The sources of this kind of rent are the attractiveness of the location within the settlement and the state of improving real estate. Under the monopoly land rent of urban real estate should be considered part of the additional income, which is obtained through the "privilege price", which is characterized by the limited and superbly unique fragments of urban areas (historical, cultural, natural, recreational, commercial, etc.). The source of the monopoly rent is the social motivation of the prestige of ownership of a highly liquid asset, which generates an excess of additional income by redistributing profits from management in other, less liquid sectors of the economy. Analysis of the formation of the uniqueness of the value of land rent of urban real estate allows us to conclude that:

- The basis of its formation is the sum of factors of monopoly rights, location, improvement and super-attractiveness of the location itself;
- The sources of its formation are the product of absolute, differential and monopoly surplus of additional income.

Realizing the connection between the rental income and the value of urban real estate through the rate of capitalization of such income, we consider the methodology for determining the rate of capitalization.

3. METHODOLOGY OF DETERMINING CAPITALIZATION RATE

At present, the values of real estate value are obtained by appraisers through consideration of the capitalization rate (as a type of discount rate), which is applied subject to the unchanged additional income in future periods and takes into account all risks and rewards of ownership through the basic formula of the income approach (1):

$$V = I/R, \text{ where } (1)$$

V – value of real estate;

I – rental income derived from the exploitation of real estate;

R – capitalization rate (coefficient).

As can be seen from the formula below, the capitalization rate *R* is the search return rate ("profitability") that in the investor's expectations reflects the temporary value of money, as well as the risks and rewards of ownership [C17; IVS230; 12]. In turn, the determination of the capitalization rate *R* is ensured by the accuracy of the statistical analysis of the market capitalization rates [C20, IVS230; 12] by the formula (2) derived from formula (1):

$$R = I/V (2)$$

Thus, the search value of the market rate of capitalization (coefficient) *R* is based on statistical surveys of rental income *I* and accordingly is extracted exclusively from market prices for real estate – *V*. At the same time, the specificity of real estate requires statistical observations of rental income, not only in time, but also in space. It should be noted that the IVS rules allow for the construction of a capitalization rate based on typical "risk-free" rates of return with an adjustment for additional risks and opportunities related to a specific right to real estate, but solely in the absence of statistics on market prices for real estate [C20, IVS230; 12]. The real risk-free rate (which is more precise than the nominal value) is estimated by the types of investments in stable assets (securities, real estate, business, currency, precious metals, etc.), and risks and opportunities for investing in real estate – are valued as the product of significant

national risk factors, regional and local levels. National Valuation Standards in Ukraine offer a series of consistent valuation procedures for calculating the real estate capitalization rate, namely:

- Comparison of projected annual net operating income (rental income) and selling price (offering prices) with respect to similar real estate;
- Analysis of alternative types of investment and determination of risks of investing in an object of valuation in comparison with investments with minimal risk, as well as, if there are other additional investment risks associated with the object of valuation;
- Other valuation procedures that characterize return on invested capital and return on invested capital and are justified in the property valuation report [p.15; 13].

It is clear that the level of accuracy of the rate determination in the proposed method is considerably inferior to the R indicators extracted on the basis of market agreements, since the latter also take into account the typical "risk-free" nature of urban real estate investments and additional risk groups as well as opportunities at the national and local levels.

4. CAPITALIZATION OF URBAN REAL ESTATE LAND RENT: CASE STUDY OF ODESSA

Odessa is the third most populous city of Ukraine and a major tourism center, seaport and transportation hub located on the northwestern shore of the Black Sea. It is also the administrative center of the Odessa Oblast and a multiethnic cultural center. The city currently covers a territory of 163 km² (63 sq mi), the population density for which is around 6,139 persons/km². According to the results of mass continuous evaluation of Odessa land in 2016, for the purpose of determining the urban development value of the area using ArcGIS [14], for the first time, a territorial visualization of the market value of the real estate of the city was obtained. Based on the task of evaluation, a relief of prices for the most common segment of the real estate of the city - two-room apartments. In fig. 1 shows the relief of two identified characteristic centers of spatial heterogeneity market value of real estate in Odessa. The analysis of the statistics of significant territorial differences of such real estate within the boundaries of the integral and homogeneous territories of the urban development value indicates the existence of certain spatial risks. Thus, according to formula (1), the given statistics of values of the market value of real estate of Odessa are reverse-proportional values of the capitalization rate of additional income of the given segment real estate, and such values are characterized by a similar relief of the range.

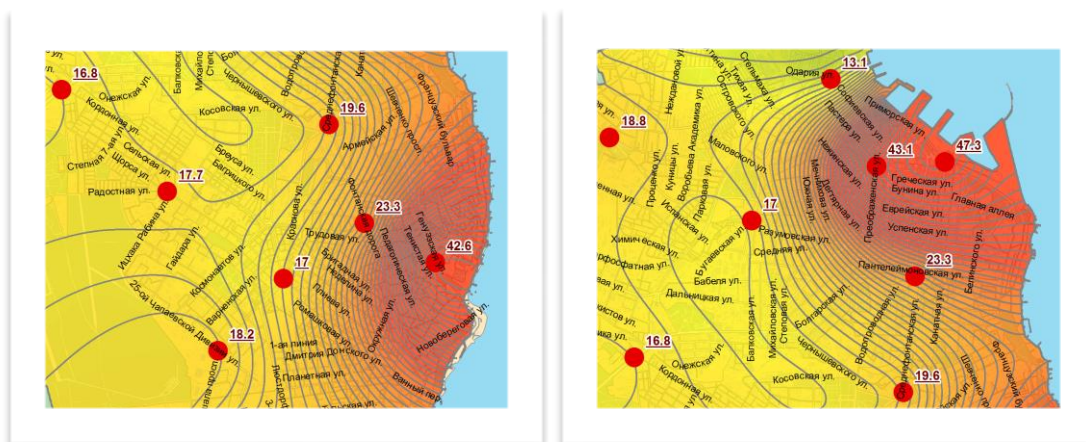

Fig.1 – Fragments of the map of spatial heterogeneity market value of real estate in Odessa as of the beginning of 2016, UAH / sq. m.

As seen from the above, the rate of capitalization of urban real estate is characterized by not only the generally recognized risks of the type of economic activity, national and local risks, as well as spatial risks within the city. And, obtained with the indicators of the spatial heterogeneity of risks, the capitalization rate – is the targeted factor of investment in urban real estate, and thus should serve as a convenient tool for modeling such processes. The assumption that the above phenomena of spatial heterogeneity of risks reflect the impact of land rent through capital and the intuitive reaction of capital (which is self-sufficient, since it is understandable without land rent [p.33; 15]) on the territorial nature of changes in rental income – the identified factor deserves due attention and further research. According to the authors of the article, the purpose of such studies should be to identify and study the agents of influence as localized fluctuations in rental income in space and time, and on the laws of their influence on the capitalization of such income, endowed with the famous statement of Alfred Marshall "specific peculiarity, having priority theoretical and practical value." One of the final practical tasks regarding the results of such researches should be the methodology for solving the problems of conscious modeling with the help of the rate of capitalization of the level of market value of urban lands, taking into account the spatial heterogeneity of risks in order to weighed down the effective investment of capital in urban real estate.

5. CONCLUSION

The study shows that the capitalization rate as the most important indicator in the valuation of real estate can be characterized by spatial heterogeneity. It can vary not only in regard to the financial market conditions and the risks of economic activity that are relevant for region or country, but also even within a city territory, reflecting the difference in local risks of real estate investments, as well as natural and technogenic risks. In this regard, spatial analysis, GIS and cartography are becoming increasingly important when assessing the land of large cities.

LITERATURE:

1. Ambrose, Brent, and Hugh Nourse. "Factors influencing capitalization rates." *Journal of Real Estate Research* 8.2 (1993): 221-237.
2. Capozza, Dennis R., and Robert W. Helsley. "The fundamentals of land prices and urban growth." *Journal of urban economics* 26.3 (1989): 295-306.
3. De Groot, Rudolf. "Function-analysis and valuation as a tool to assess land use conflicts in planning for sustainable, multi-functional landscapes." *Landscape and urban planning* 75.3-4 (2006): 175-186.
4. DiPasquale, Denise, and William C. Wheaton. *Urban economics and real estate markets*. Vol. 23. No. 7. Englewood Cliffs, NJ: Prentice Hall, 1996.
5. Eckert, Joseph K., Robert J. Gloude-mans, and Richard R. Almy, eds. *Property appraisal and assessment administration*. Intl Assn of Assessing Off, 1990.
6. Evans, Richard. "A transfer function analysis of real estate capitalization rates." *Journal of Real Estate Research* 5.3 (1990): 371-379.
7. International Valuation Standards – [Електронний ресурс]. – Режим доступу: http://smao.ru/files/dok_novosti/2013/perevod_mco.pdf
8. Krause, Andy L., and Christopher Bitter. "Spatial econometrics, land values and sustainability: Trends in real estate valuation research." *Cities* 29 (2012): S19-S25.
9. Sivitanides, Petros, et al. "The determinants of appraisal-based capitalization rates." *Real Estate Finance* 18.2 (2001): 27-38.
10. Збірник «Регіональний розвиток та просторове планування територій: досвід України та інших держав-членів Ради Європи». В.С. Куйбіда, В.А.Негода, В.В.Толкованов. – Київ, Видавництво «Крамар», 2009, 170 с.

11. Капітал К.Г. Маркс– [Електронний ресурс]. – Режим доступу: https://royallib.com/book/marks_karl/kapital.html
12. Колосюк А.А. Критерії несумісності оцінювання земель України (у т.ч. для цілей оподаткування) до вимог ринкової моделі економіки/Бізнес-навігатор: науково-виробничий журнал. Вип. 1 (36), Вид-во МУБіП, Херсон - 2015. – с. 173-183.
13. Національний стандарт №2 “Оцінка нерухомого майна” – [Електронний ресурс]. – Режим доступу: <http://zakon2.rada.gov.ua/laws/show/1442-2004-p>
14. Палеха Ю.М. Візуалізація ринкових показників вартості нерухомості м. Одеса для формування містобудівної цінності території за допомогою ArcGIS/ Палеха Ю.М., Стадніков В.В., Колосюк А.А., Лиса О.В.//Матеріали III Міжнародної науково-практичної конференції «Геоінформаційні технології у територіальному управлінні, Одеса: ОРІДУ НАДУ, 2016 – С.101-102;
15. Принципы экономической науки А. Маршал – [Електронний ресурс]. – Режим доступу: <http://www.library.fa.ru/files/Marshall.pdf>

A REVIEW OF MANAGEMENT OF INFRASTRUCTURE ROAD ASSETS

Vasiliy Mitinskiy

*Odessa State Academy of Civil Engineering and Architecture, Ukraine
mitinskiy.v@gmail.com*

Olena Vashchynska

*Odessa State Academy of Civil Engineering and Architecture, Ukraine
vashin2989@gmail.com*

Nataliya Shyriaieva

*Odessa State Academy of Civil Engineering and Architecture, Ukraine
n.shyriaieva@ogasa.org.ua*

Olha Khmaruk

*Odessa State Academy of Civil Engineering and Architecture, Ukraine
nowolya@gmail.com*

ABSTRACT

Purpose and research question - The destruction of infrastructure assets, including existing of the road systems, is increasing. In the process of exploitation of road assets, the excessive impact of transport vibrations, water-heat and low-temperature loads, soil washing leads to a significant reduction in the regulatory criteria for their safety, premature technical wear of surface plates, cracks, unevenness, lowering. Increasing the number of seismic fluctuations and floods violates the integrity and stability of road systems. Inadequate and untimely financing leads to increased costs for the prevention and rehabilitation of road systems. The purpose of the survey is to analyze problems and trends in the management of infrastructure road assets; correcting the content of educational programs in a new global context and principles of sustainable development.

Methods of research - Review of scientific and applied information in the public domain about the organizational mechanism of infrastructure assets management in the context of global tasks and problems. The subject of the study is knowledge management in the field of infrastructure of the road assets.

Results - This study does not have a specific grant from any funding agency in the public, commercial or non-profit sectors. It is expected that the transitional results of interdisciplinary research will contribute to the implementation of global programs aimed at improving knowledge management in the field of infrastructure asset management, including the road system.

Conclusions - In general, the trends in the implementation of the principles of global programs for transforming the economy based on digital technologies show a positive trend. For example, innovative proposals by scientists and business practitioners have helped to reduce the infrastructure gap of assets in many countries. However, factors of negative impact, including natural disasters, economic instability, slow processes of transformation of human capital and organizational culture have been revealed.

Keywords: *global challenges, knowledge management, recycling, sustainable development goals (SDGs); transdisciplinary research*

1. INTRODUCTION

In connection with the increase in the population, urbanization, natural disasters, physical depreciation of infrastructure assets, many countries need to improve them [1]. Overhaul of sidewalks, construction and subsequent maintenance of airfields requires huge public investment [2]. State initiatives are not always focused on insurance of public infrastructure, including roads and bridges [3]. Also, «globally, 2017 was a horror year for natural disasters. Hurricanes, floods and wildfires in the Americas, earthquakes in Mexico and the Middle East, and floods in Asia and Africa sadly demonstrated with heart-wrenching repetition the devastating economic and community impacts of these events. In Australia, we are particularly exposed to extreme cyclones and floods. It is inevitable that we will again face a national recovery and reconstruction bill in the billions of dollars. And science is telling us that natural disasters are increasing in intensity and likely, in frequency» (Mark Senkevics. 2018) [4]. Revealed, «that while not all EU member states exhibit signs of environmental imbalances, there still are significant differences between the EU 15 and the states that have acceded to full membership after 2004» (Kokotović, Kurecic, Cingula. 2016) [5]. Obsolete infrastructure assets and natural disasters are not the only problems. Analysts note the passive management of a certain part of production companies with regard to the transition to a circular economy and digital technologies. Perhaps, this phenomenon is due to the aging of intellectual capital or the lack of interdisciplinary knowledge. So, there are cases of insufficient level of knowledge and practical skills of graduates in the field of management, engineering, geotransport, remote sensing, management of road projects [6, 7]; Availability «dark triad» personality traits of engaged human resources can create potential for organizational crises [8].

2. STATUS OF INFRASTRUCTURAL ASSETS IN UKRAINE

The overall integral index of the dynamics of infrastructure development by regions of Ukraine for 2017 is shown in Figure 1. The information is compiled on the basis of data from a publication prepared by the Polissi a Foundation for International and Regional Studies in cooperation with the Friedrich Ebert Foundation in Ukraine.

Figure following on the next page

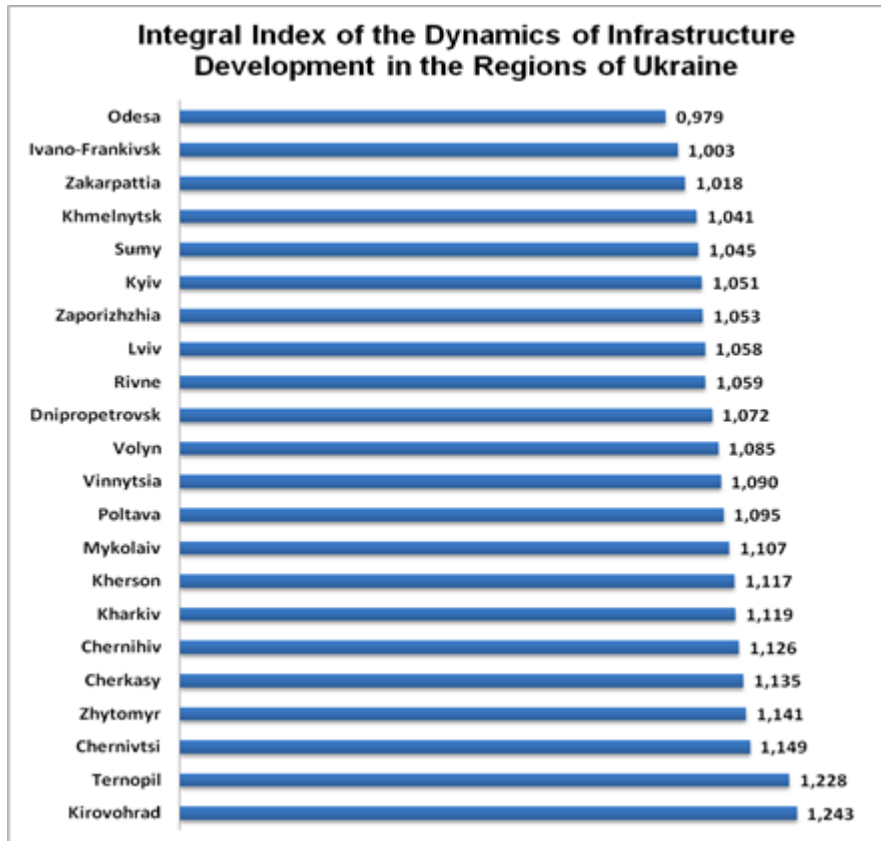

Figure 1: Integral Index of the Dynamics of Infrastructure Development in the Regions of Ukraine [24]

The integral indices of the development of the transport component by regions of Ukraine for 2017 are shown in Figure 2. The information is compiled on the basis of data from a publication prepared by the Polissi of Foundation of International and Regional Studies in cooperation with the Friedrich Ebert Foundation Representative Office in Ukraine [24].

Figure following on the next page



Figure 2. Indices of Infrastructure Development of the Transport Subsystem of the Regions of Ukraine [24]

According to the above data, it can be seen that Ukraine has a high infrastructure breakdown of assets, including road assets. In order to reduce this gap in future scientific research, a more detailed analysis of indicators and development of measures to improve the object of study is planned. Below in this article, a theoretical overview of innovative scientific proposals in the sustainable development of infrastructure assets is presented.

3. CONTRIBUTION OF SCIENCE IN THE MANAGEMENT OF INFRASTRUCTURAL ROAD ASSETS

3.1. Pavement design

A historical overview of the development of methods of the design of pavements is presented in [9]. «The introduction of French asphalt mix design to UK airfield pavements is proposed to provide a sustainable and a better whole-life cost solution. However, in order to use these materials, a detailed laboratory investigation to assess the material properties and their impact on UK pavement design, materials specification and maintenance requirements is needed. The principles of pavement design in the UK and France considering materials specification, traffic loading and environmental variations are investigated» (Hakim; Widyatmoko; Fergusson; Richardson. 2014) [10]. The effect of recycling agent in samples of asphalt mixture is studied, one of the results is the development of a technique for estimating the viscosity of asphalt and its aging tendency [11]. «Roofs are important components of buildings and can be designed and/or retrofitted with photovoltaic (PV) and green-roof (GR) systems to produce energy and to improve stormwater management. The analysis demonstrates that a GR-PV system is a low-risk investment generating lower energy and carbon-emission payback time in comparison with separate GR and PV systems» (Ali Jahanfar; Brent Sleep; Jennifer Drake. 2017) [12]. There is a trend of breakthrough innovative technologies with the use of secondary building materials

for road systems. It is shown that such technologies increase their stability and financial savings in repair and restoration works, but their longevity has not been proved in time [13]. The strength of rejuvenated asphalt coatings depends on the amount of the recycling agent [14]. As anti-aging composites of the asphalt mixture, scientists propose to introduce Pongamia oil and Composite castor oil [15]. Among recycling technologies, a concrete mix based on electronic waste, which allows reducing dumping emissions into the environment, is of practical interest [16]. The hypothesis of the correlation of the roughness of rural road surfaces and their safety in operation, in particular, emergency situations, is investigated. The results confirmed this relationship [17]. Laboratory tests of studying the aging behavior of mixed asphalts in various cycles of heating, cooling and watering showed that «the ageing of energy reduced pavement concepts is not very critical and that the application of such pavements therefore pro CO₂ a good solution for saving CO₂ emissions and prolonging the installation season» (Raab, C., Camargo, I., Partl, M.N. 2017) [18].

3.2 Review of methods for assessing and monitoring infrastructure road assets

The number of scientific studies on the assessment and monitoring of infrastructure road systems, including the effects of natural disasters on their condition, has increased. For example, scientific monitoring studies are under way to develop optimal solutions for long-term monitoring of road systems in order to develop optimal solutions to increase their longevity in conditions of frequent flooding [19]. The technologies of digital insurance of risks affecting the change of infrastructure assets are actively discussed [20]. The practical value of innovative ideas is given in [21]. «The focus of this document is to provide a wide range of ideas and options to improve the inclusion of environmental sustainability throughout the road transportation project cycle (system planning, project planning and design, construction, and operation and maintenance) based on environmental sustainability indicators and highlighting environmentally sustainable products and materials for road construction. Sustainable economic growth in low- and middle-income countries is a key to poverty reduction and shared prosperity, which in part is dependent on reliable and safe transportation systems. Road and highway systems provide a critical function in creating and maintaining a desirable quality of life» (Montgomery, Robert; Schirmer, Howard Jr.; Hirsch, Art. 2015). In developing countries, the method of preventive maintenance and rehabilitation (M & R) activity profiles has been proposed as an alternative tool for assessing and monitoring aerodrome pavements. With this method of management, the life cycle of the aerodrome pavements [2]. «The use of remote sensing techniques offers new potential for pavement managers to assess large areas, often in little time. Although remote sensing techniques can never entirely replace traditional geotechnical methods, they do provide an opportunity to reduce the number or size of areas requiring site visits or manual methods» (Schnebele, E. 2015) [7]. For accelerated testing of road systems mobile simulators have been developed [22]. Innovative software is offered, «using the software, both the present condition of the pavement can be examined and future performance based on expected traffic values can be predicted» (Morova, Terzi, Gökova, Karaşahim. 2016) [23].

4. CONCLUSION

We can draw such conclusions:

1. At the stage of the digital scientific-oriented era, knowledge management is entering a new level of university and business partnerships in global sustainable development programs, including infrastructure assets. This requires activation of benchmarking of intellectual capital, thinking and practical skills.
2. In the management of infrastructure assets required to ensure high-effective sustainable development need to consider such strategies: a correct reform management of global

challenges; development institutional and individual capacities; the ensuring stable and sufficient funding; a simplified investment process.

3. The high probability of natural cataclysms and increased costs for insurance are becoming a significant driver in the improvement of infrastructure assets.
4. The speed of developing digital technologies, such as remote sensing, advanced analytics, autonomous operations, integrated planning and control, requires a qualitative upgrade of university educational programs and intellectual capital of teaching staff, raises the requirements for the results of training students in engineering, management and other specialties related to management of infrastructure assets, in particular, in Ukraine.

LITERATURE:

1. Ali Jahanfar; Brent Sleep; Jennifer Drake. 2017. Energy and Carbon-Emission Analysis of Integrated Green-Roof Photovoltaic Systems: Probabilistic Approach. Citation of *Journal of Infrastructure Systems* 24(1):04107044.
2. Bachar Hakim; Iswandar Widyatmoko; Carl Fergusson; John Richardson. UK airfield pavement design using French asphalts. Citation of *Proceedings of the Institution of Civil Engineers - Transport*. Volume 167 Issue 1, February 2014, pp. 27-35. ISSN 0965-092X | E-ISSN 1751-7710.
3. Bogdanovic, M., Cingula, D. Dark Triad of Croatian Management Students. Article in *Central European Business Review*. February 2016. DOI: 10.18267/j.cebr.136.
4. Fawaz Kaseer, Lorena Garsia Cucalon, Edith Arambula, Jon Epps. Practical tools for optimizing recycled materials content and recycling agent dosage for improved short-and long-term Performance of rejuvenated binder blends and mixtures. *Asphalt Paving Technology: Association of Asphalt Paving Technologists-Proceedings of the Technical Sessions*. March 2018.
5. Filip Kokotović, Petar Kurecic, Domagoj Cingula. The Greenhouse Gas Emission in the EU: VAR Analysis of the Relevant Variables. Conference Paper. June 2016 DOI: 10.18775/ijmsba.1849-5664-5419.2014.29.1004.
6. <http://library.fes.de/pdf-files/bueros/ukraine/13246.pdf>
7. <https://www.the-digital-insurer.com/natural-catastrophe/>
8. Ilaria Menapace, Lorena Garcia Cucalon, Fawaz Kaseer, Eyad Masad, Amy Epps Martin, 2018. Application of Low Field Nuclear Magnetic Resonance to evaluate asphalt binder viscosity in recycled mixes. Citation of *Construction and Building Materials* 170 (2018) pp. 725–736.
9. J.C. Nicholls, M.Wayman, K. Mollenhauer, C. McNally, A. Tabaković. A.Varveri, S. Cassidy, R. Shahmohammadie, R. Taylor. Effects of using reclaimed asphalt and/or lower temperature asphalt on availability of road network. Conference: Transport Research Arena, TRA 2014. At: Paris, France. Volume: Proceedings of the transport research arena 2014. DOI: 10.1201/b18538-83.
10. Lin, J.-D., Ho, M.-C., 2016. A comprehensive analysis on the pavement condition indices of freeways and the establishment of a pavement management system. Citation of *Journal of Traffic and Transportation Engineering* (English Edition) (2016).
11. M. Sultana, G. Chai, S. Chowdhury, T. Martin, Deterioration of flood affected Queensland roads - an investigative study. *International Journal of Pavement Research and Technology* (2016),
12. Manfred N. Partl, Christiane Raab, and Martin Arraigada. Innovative asphalt research using accelerated pavement testing, *Journal of Marine Science and Technology*, Vol. 23, No. 3, pp. 269-280 (2015) 269. DOI: 10.6119/JMST-014-0326-1.
13. Mark Senkevics. 2018. Citation of article. De-risking climate challenges.

14. Montgomery, Robert; Schirmer, Howard Jr.; Hirsch, Art. 2015. Improving Environmental Sustainability in Road Projects. Citation of *Environment and natural resources global practice discussion paper*; no. 2. World Bank, Washington, DC.
15. Muhammad Irfan, Muhammad Bilal Khurshid, Shahid Iqbal, Abid Khan. Framework for airfield pavements management - an approach based on cost-effectiveness analysis. Citation of *Eur. Transp. Res. Rev.* (2015) 7:13.
16. Ninat Morova, Serbal Terzi, Süleyman Gökova, Mustafa Karaşahim. Pavement Management Systems Application with Geographic Information System Method. 2016. *Journal of Natural and Applied Sciences*. Volume 20, Issue 1, 103-110, 2016/ DOI: 10.19113/sdufbed.69064.
17. Pereira, P., Pais, J., Main flexible pavement and mix design methods in Europe and challenges for the development of an European method, *Journal of Traffic and Transportation Engineering (English Edition)* (2017), DOI: 10.1016/j.jtte.2017.06.001.
18. Pratik Nayak & Umesh C. Sahoo (2015): A rheological study on aged binder rejuvenated with Pongamia oil and Composite castor oil, *International Journal of Pavement Engineering*, DOI: 10.1080/10298436.2015.1103851.
19. Raab, C., Camargo, I., Partl, M.N., Ageing and performance of warm mix asphalt pavements, *Journal of Traffic and Transportation Engineering (English Edition)* (2017), DOI: <http://dx.doi.org/10.1016/j.ijprt.2016.10.002>.
20. Schnebele, E., Tanyu, B.F., Cervone, Review of remote sensing methodologies for pavement management and assessment. Citation of *G. et al. Eur. Transp. Res. Rev.* (2015) 7:7
21. Senthil Kumar Kaliyavaradhan, Arjun Ramakrishna Kurup. Novel Fibrous Concrete Mixture Made from Recycled PVC Fibers from Electronic Waste. *Journal of Hazardous, Toxic, and Radioactive Waste* 21(2) April 2017.
22. Sikai Chen, Tariq Usman Saeed, Samuel Labi. Impact of road-surface condition on rural highway safety: A multivariate random parameters negative binomial approach. *Analytic Methods in Accident Research*. September 2017. DOI: 10.1016/j.amar.2017.09.001.
23. Strategic Infrastructure 2014 - Reports - World Economic Forum
24. The Global Risks Report 2018 - Reports - World Economic Forum

MANAGEMENT OF ECONOMIC PROCESSES OF CITY SPACE SYSTEMS

Olena Bileha

*Odessa State Academy of Civil Engineering and Architecture, Odessa
olena_bileha@ukr.net*

ABSTRACT

The modern city is the focus and the result of the urbanizational process, which leaves the mark on the development of an existing social model. If one explores the city as an element of a society, then it appears as a socio-spatial form of its existence. A high level of the centralization and a strong powerful vertical with weak horizontal links, including between regions and cities, leads to a distorted vision of the position of one or another region or a big city in the economy of the state, in the social, cultural sphere and in the politics. Large cities with large areas and number of population at a certain stage of their development face the invocation of spatial problems caused by various objective factors and conditions that are inherent in one or another territory. The bigger the area of the city, the more irregularly the potential of the population, of material and cultural resources is located on its territory, the more acute the problems of spatial disproportions are, which may under certain conditions pose a threat to the further development and the prosperity. Taking into account a many-year disregard of the importance of the state regional policy concerning the development of large cities, a reduction of its size, a suspension of the construction in it, a crisis in management, an ignoring of the effect and consequences caused by various instruments and measures of sectoral policies on the city's space, an accessibility of its territories, a building activity, an attractiveness for life and running business, their competitiveness and investment attractiveness, their stability and security, their tourism potential and social prosperity, it is proposed to study the development of space, the efficiency of its use and the degree of importance of increasing the prosperity of large cities as the commanders of states of our country. Afterwards, today, in the context of growing the global civilizational inquiries, the changes in the role and the position of individual cities in a world system of economic and political coordinate systems, the question of production a new effective state regional policy, especially the regulation of the development of large cities and the effective use of their spatial potentials in Ukraine, is becoming extremely relevant.

Keywords: *city, space systems, state regional policy, territory*

1. INTRODUCTION

To the modern world trends of the further development of a mankind there can be referred: urbanization, demographic explosion, metropolitan, globalization, and so on. These trends form new conditions of human's existence, fundamentally changing the surroundings of its environment and the ways of activity. It is interesting that these trends not only open up new prospects for the development of the mankind, but also interact with each other, creating positive and negative synergetic effects. It increases the unpredictability of social, economic, socio-cultural, environmental consequences, it affects the intensity of their course and also complicates the tasks that appear in front of the authority at the formation of the policy development. Naturally, that all of the above regards not only the civilization as a whole, the world, but also the cities, because the city for modern urbanized countries can be considered as the primary frame-creating element of a higher level of social organization, i.e. the country. The problem of functioning of cities as complex socio-economic systems, with their impact on the regions is not only scientific, but also practical, because its solution helps to define more clearly the ways of the further development.

The questions of development and functioning of Ukrainian cities are studied in the works of scientists in various fields of knowledge, such as V. Artemenko [1, 2], V. Babaev [3, 4], Y. Boiko [5], N. Hrynychuk [11, 12], O. Karlova [12, 13] and others. The urbanization, as a historically specified process, has put in the first place the problems of modern cities. In this regard, there is a need to find new paradigms in the functioning of cities and the ways to solve problems of the urban management.

2. DEFINITION OF THE PROBLEMS OF PLANNING AND ORGANIZATION OF CITY SPACE SYSTEMS.

Every city consists of buildings and free spaces, which are functionally divided into streets and roads – the arteries of the city, the squares, the green areas, the waterfront and coastal areas, the yards and the adjoining territories. The planning of the urban spaces should be one of the most important areas of the urban planning in general. Throughout the world, the responsibility for the planning of the urban spaces is basically taken over by the city. When planning new cities, public spaces are incorporated into the urban planning's documentation in a general form. When detailing - during the next design stages - there should be refined designed solutions for typologically similar spaces and individual, unique zones [14]. During the process of exploitation, public spaces undergo certain changes even within a certain configuration-the functions they perform are changed, the equipment for conducting business activity, the elements of improvement and small architectural forms, the social activities that are in the demand among the population. The percentage of free and accessible areas in the city is becoming less. The planning takes place in the areas that have already been developed by the city. The free public spaces laid down in previous times are becoming hostages of the increasing commercialization (temporary structures, advertising pillars, unauthorized trade) and are addicted to car parking. The changes that have taken place in the post-Soviet society and the economy are not reflected in any way in the urban spaces. Their configuration, laid down in Soviet times, has remained without changes and has not acquired new meanings. The existing urban spaces are not planned or are planned for outdated principles and basics, basing on an outdated legislative and regulatory framework and lack of basic urban analysis. The coils of the main problems in urban spaces' planning are the lack of a chain: statistical data collection – data analysis – impacts' forecasting – planning – statistical data collection... Because of that, the planning faces certain difficulties that make the quality design be impossible to exist.

2.1. The main problems in the formation of the urban spaces:

1. Lack of a systematic approach to the urban spaces' planning [18]:

- no development strategy and the program of the urban spaces' planning in the city;
- reason for the right to making decisions. The traditional architectural school of the Soviet period did not take into account the involvement of participants in the process of use of the space. For cities, there was made a clear classification of spaces and processes that should take place in them. The opinion of the society was not taken into account at all;
- lack of a modern regulatory and legislative framework for the urban spaces' planning is characteristic. The world practice of the planning of the urban spaces has gone far ahead in comparison with modern Ukrainian realities. It is enough to say that the Ukrainian legislative framework lacks the basic terms and the fundamental basis for the formation of spaces. Without the introduction of an updated regulatory framework it is almost impossible to move forward;
- poor quality of accepted design decisions. The design of free urban spaces takes place in the "Soviet trend" with an unattractive design, outdated technologies, without the use of energetic and efficient technologies [15].

- lack of modern standards of the urban space quality. Today there are no quality standards that should determine the aesthetic and quality level of elements of landscaping and gardening, outdoor furniture, paving, lighting, which encourages both public services responsible for ordering projects of renovation of public space, and designers and patrons to make ill-considered, economically unjustified decisions, often of low aesthetic quality.
- no transparent process of finding the best solution. The competitive practice worldwide is the most democratic way to find the best solution. Unfortunately, today in large cities there is almost no competition practice, the design decisions are made unilaterally, based on the special opinion of the customer. The choice of a contractor during the public procurement's procedure (as a designer, construction contracting organization, and manufacturer) is based on the lowest cost of services, which does not contribute to the quality of work at all levels. There is no practice of project seminars (workshops) with the participation of all interested parties for the formulation of the problem, the formation of the technical task for the designer.
- lack of mechanisms of the influence on the formation of urban spaces by the executive authority. After the changes in the state legislation in 2011, the city administrations in Ukraine are actually deprived of the levers of the influence on the quality and aesthetics of the formation of the urban spaces and the regulation of urban development in general [19].
- lack of professional expertise. Taking into account that today the customer is the main expert of the project (institutions of advisory bodies – the architectural and urban planning council, trade unions take an inactive position or limited ones in the right of the influence the situation), the quality of the accepted design decisions is often low. There is no professional discussion of problems in the society. The research institutes don't exist or are inactive.

2. Problems inherent in the process of the planning and the organization of the urban spaces of the city are characteristic for the process of their creation and operation [7]:

- lack of clear and precise algorithms. Taking into the account the large number of the participants in the process of creating the urban spaces leads to a situation where "the left hand does not know what the right hand is doing." The inconsistency of actions leads to large financial costs in the process of the construction and the exploitation of the urban areas and the permanent repairs;
- complexity of the communication and the coordination between a large number of participants in the process. The branching of the responsibility for certain areas of the urban space between different balance holders leads to a lack of sense of "the master of the city";
- lack of the prioritization of spaces. There are always more and less important spaces in the city. They may vary in the function, in the size, and most importantly – in the value for the local community. Lack of system, lack of scientific support and lack of long-term strategy and tactical measures lead to low quality in the creation of urban spaces;
- lack of the real competition between construction contractors and organizations responsible for the maintenance of the territories. The imperfect procedure of public procurement leads to the fact that commercial structures are not interested in working with the city budget;
- ignoring of certain regulatory requirements in the creation and operation of the urban spaces. The lack of quality control system for the implementation of both project documentation and construction work leads to the ignoring of certain regulatory requirements. Especially this concerns the question of the accessibility and the activities for people with limited mobility.

3. Existing mechanisms of citizens' participation (public hearings, discussions, public councils, complaints system, etc.) do not ensure the effective implementation of the "right to the city" -

the right of citizens to an equal participation in the urban development. There is no system of the accessible information of business and citizens about their rights and obligations in the field of the urban public spaces. Private interests in the urban space often contradict with the public and dominate them. The decision-making processes are not transparent; the information that relates to the urban spaces development is often not available to the citizens. This is becoming a source of the conflict. The urban public space is a limited shared resource. Accordingly, the abilities to conduct economic activities in it are also limited. The uncontrolled commercialization of public space causes the dominance of economic functions and leads to spatial degradation.

4. Imperfection of a financial support. The rates at which entrepreneurs pay for the advertising are not economically reasonable. The absence of competitive mechanisms for granting the right to advertise constrains the growth of revenues to the city budget. The amount of the equipment for dismantling of illegal advertising structures is insufficient. The payment for the use of the urban public spaces is not referred directly to the development of these facilities. The attraction of funds from private individuals (sponsors and patrons) for the development of the urban space is irregular and often not transparent.

5. Violation of legal regulation. The existing system of regulation of the improvement of questions is characterized by the following problems:

- insufficient regulation at the national level of questions on the placement of mobile small retail network; unsettledness at the national level on the placement of information signs and nameboards that are not considered as advertising;
- existence of insufficiently severe sanctions on administrative offenses for violation of rules of the improvement of settlements;
- absence at the level of the national legislation of the mechanism of the direction a part of the penalties collected from violators of rules of the improvement of settlements.

6. Existing mechanisms for monitoring the state of the urban environment and the control of violations in the field of the urban spatial development are ineffective. There is a large number of supervisory bodies, but there are no clear mechanisms, criteria and standards of control. There are no scientifically based, modern monitoring systems and quality standards (comfort, availability, security, level of service) of the urban environment, which would allow to assess effectively its condition and to develop measures to solve problems with the help of modern electronic means and software. The assessment of the state of the urban space is ineffective and opaque, as a result of which the budget funding is often directed not to those objects (spaces) that really need it. There is no independent assessment and analysis of the urban spatial development.

3. BASICS OF SPATIAL DEVELOPMENT OF CITY SPACE SYSTEMS

The nature of big cities is dynamic, they are in a state of a constant change. However, over the past few decades, the world's cities have transformed in a particularly remarkable way. Moreover, one can name the main driving force of these transformations – a neoliberal restructuring. The results of the transition to a post-industrial post-fordist economy that, according to David Harvey, "are reflected in the spatial forms of our cities, in which the proportion of fortified territories is growing, which is closed for the community of the privatized public spaces that are under a constant supervision." Harvey writes about the transition to an "entrepreneurial" model of the urban management. This model provides a competition between cities and private-public partnership, which results in profits for private companies, and costs become public. These are just some of the features of the new face of the

city [8, 9]. In the early 1990s, these global processes became relevant for Eastern Europe and Ukraine in particular. Our cities have also faced the problems of deindustrialization, privatization and commercialization of public space and are trying to join the global long-distance competition, although, of course, the post-Soviet space has its own specifics [20]. In a broad sense, the management is understood as the management of certain processes in accordance with a pre-designed program, aimed at achieving a certain goal. It is worth noting that in the management it is advisable to be guided by factors, laws, principles and criteria of the territorial organization, which allows taking into account the features of the big city: history, sources of origin, formation, quantitative and qualitative specifics of territories, composition, quantitative and qualitative characteristics of its subsystems, their subordination, the definition of the main subsystems, that is the basis, on which, first of all, the economic space of the city is based, and which is the main sources of the urban space's development, trends and prospects, transformation into a qualitatively new integrated spatial system of a large city [17]. Spatial potential is a multi-level object of management, being, on the one hand, an element of socio-economic and territorial-production system at the national level, and, on the other hand, - being in the conditions of specific microeconomic processes and territorial planning conditions. This feature determines the methods of management of the urban territorial resources [6]. The basis of a properly ordered use of the spatial potential of the city is a comprehensive solution of five main tasks:

1. economic - aimed at the rational use of spatial resources with an effective placement and use of the main factors of production;
2. technical - providing solutions for problems related to the terrain, soil quality, other engineering and geological conditions;
3. social - ensuring the performance of the main social functions of urban space-the provision of housing, education, services, labor, recreation, management;
4. aesthetic - providing full aesthetic qualities of the surrounding environment;
5. environmental - ensuring the life of the environment, which is expressed in the physical, sanitary and climatic parameters, the protection of the population of the city from the impact of negative factors, the rational placement of industrial areas relatively to recreation and living areas.

The experience of most European countries shows that the rational management of the potential of a large city is one of the main ways to improve the efficiency of its spatial development. A particular importance in this process is the study of methodological principles and approaches to the management of the potential of spatial development of a large city [16].

4. CONCLUSION

Liberalization of the urban development processes is an important element in the development of democratic principles in society. However, in order to achieve positive results in such approach should develop a competitive market, create an institution of the urban community and a well-established system of control over the formation of the urban space. In the conditions of post-Soviet mentality and economy in Ukraine this system does not work. Today one have an unprecedented number of violations of the urban planning's legislation, the delight of the urban free spaces, which negatively affects the overall quality of life in the city. Recommendations for the development of the urban spatial systems determine the organizational basis for the creation of a single mechanism of territorial, economic, social and cultural interactions between the subjects of power, business, the public that will allow establishing possible conditions that contribute to the economic, cultural and social development of the city. The main purpose of creating the urban spatial systems is the rational use of material, labor and financial resources on the principles of their diversification,

coordination of interests as authorities of the appropriate level, the public and business representatives. They are:

- strengthening of the internal consolidation of economic, social and cultural development of individual territorial communities;
- ensuring the concentration of economic resources on the priority development areas with relevant sectors;
- ensuring the approximation of the unity of living conditions of the population, government agencies and business in certain areas;
- development of organizational and legal forms of cooperation of territorial communities with business and government;
- implementation of the program and target method and innovative technologies for facilitation of the interaction between territorial communities, business and government.

LITERATURE:

1. Artemenko, V. (2006). Indicators of sustainable socio-economic development of regions. *Rehionalna ekonomika*, №2, p. 90-97.
2. Artemenko, V. (2005). Comprehensive assessment of the effectiveness of socio-economic development of regions on the main criteria of the quality of life of the population. *Rehionalna ekonomika*, №3, p. 84-92.
3. Babaiev, V.M. (2004). City as a social-management system. *Upravlinnia suchasnym mistom: Nauk.-prakt. zhurnal*, №1-3 (13), p. 154-158.
4. Babaiev, V.M. (2004). Sustainable and safe development of the metropolis: economic, social, environmental aspects. *Upravlinnia suchasnym mistom: Nauk.-prakt. zhurnal*, № 4-6 (14), p. 234-241.
5. Boiko, Y. (2007). Conceptual grounds for designing the space development of territorial and industrial systems. *Regionalna Economica*, no.1, p. 28-34.
6. Fujita, M., Krugman, P., Venables, A. (1999). *The Spatial Economy, Cities, Region and International Trade*. Cambridge: MIT Press.
7. Habrel, M. (2004). Space organization of city planning systems. *Vudavnuchui dim A.C.C., Kuiv, Ukraine*, 400 p.
8. Harvey, D. (2003). *Paris, Capital of Modernity*, NY: Routledge.
9. Harvey, D., (2003). *The New Imperialism*, Oxford: Oxford University Press.
10. Hrynychuk, N. (2004). Comprehensive socio-economic development of cities: Consideration of certain methodological approaches and mechanisms. *Upravlinnia suchasnym mistom: Nauk.-prakt. zhurnal*, №2/4-6 (14), p. 10-16.
11. Hrynychuk, N. (2004). Improvement of management of a large city on the way of socialization. *Upravlinnia suchasnym mistom: Nauk.-prakt. Zhurnal*, 2004, №1-3 (13), p.186-190.
12. Karlova, O.A. (2006). Actual problems of social and economic improvement of cities. *Ekonomika i derzhava*, №8, p. 35-37.
13. Karlova, O.A. (2007). Strategic approaches to planning the development of regional centers. *Zbirnyk naukovykh prats ChDTU, Vyp.17, ser.: Ekonomichni nauky. Cherkasy*, p. 123-126.
14. Kliushnychenko, Y. (1999). Socio-economic grounds for planning and constructing cities. *Ukrainska akademiia arkhitektury, NDPI mistobuduvannia, Kyiv, Ukraine*, 140 p.
15. Kogan, L. (2003). The city therapy. *Gorodskoe upravlenie*, no 6, p. 2-9.
16. Kryvytskyi, A., Pavlov, V. (1997). The formation and development of the territorial and industrial complex of the city. *Nadstyria, Lutsk, Ukraine*, 126 p.

17. Pavlov, V., Bortnik, S. (2005). Transport and logistic systems of the region: integration processes. Nadstyria, Lutsk, Ukraine, 259 p.
18. Pepa, T. (2006). Regional dynamics and transformation of Ukraine's economic space. Brama, Cherkasy, Ukraine, 440 p.
19. Salii, I.M. (2005). Urbanization in Ukraine: social and managerial aspects. K.: Naukova dumka. 300 p.
20. Varezkin, V., Grebenkin, V., Kirushechkina, L. (1990). The economics of architectural design and construction. Stroiizdat, Moskva, Russia, 272 p.

FACTORS AFFECTING THE DEVELOPMENT OF TOURISM INDUSTRY

Olga Kambur

*Odessa State Academy of Civil Engineering and Architecture, Ukraine
olga.kambur@gmail.com*

Nataliia Petryshchenko

*Odessa State Academy of Civil Engineering and Architecture, Ukraine
diadema@ukr.net*

Nataliia Serohina

*Odessa State Academy of Civil Engineering and Architecture, Ukraine
serohina.nata@gmail.com*

ABSTRACT

Tourism has a tremendous impact on key sectors of the economy: transportation, communications, construction, agriculture, production of consumer goods and other. The development of the tourism industry is an important component of the economic growth of any country. The article poses the following tasks: to reveal the importance of tourism for the economies of the countries of the European Union and Ukraine; to determine the main factors of influence on the development of tourism business; data collection and calculation of cluster and factor analysis of the EU and Ukraine to determine the relationships. The dynamics of the share of tourism in the GDP of the countries of the European Union and Ukraine is given. The factors that have the greatest impact on the development of the tourism industry of the countries are revealed. The analysis of dynamics of indicators of functioning of tourist branch on the basis of statistics of the European Union is carried out. The tendencies of development of tourism in the EU countries and Ukraine are considered. The main factors for clustering and factor analysis have been selected. A cluster analysis has been carried out that has made it possible to combine countries into groups according to similar characteristics. With the help of factor analysis, the main directions for the further development of the tourism industry have been identified. Leaders in tourism among the countries of the European Union are defined. Recommendations are given for countries in which the tourism services industry has not fully disclosed its potential.

Keywords: *cluster analysis, economic growth, factor analysis, indicators of the development of the tourism industry, state income tourism industry*

1. INTRODUCTION

Tourism as a sphere of economic activity is of great importance and a number of characteristic features. The importance of tourism can be viewed not only on the part of satisfying a person's needs for rest and knowledge, but also on the economic side. Tourism has many facets and directions: sports, health, green, rural and many others. People actively travel, which in some countries is one of the main components of income and affects the development of their economies and world cooperation. The tourism services market is influenced by macroeconomic factors, such as economics, culture, strategy, finance, technology, ecology and law (Gonza'lezetal, 2009). It is revealed that the level of tourism development in the region, the degree of its competitiveness have a direct impact on the level of development, competitiveness of the tourist region (ShvetsI.Yu., 2011, p.67). Studies of the development of tourism are devoted to the works of many scientists. So, Renata Seweryn, Agata Niemczyk, Krzysztof Firlej studied the influence of social networks on the organization of a tourist's stay in the country

(Seweryn R. et al., 2017, p. 256). The concept of sustainable tourism development is also important. In his work Pjerotic L. conducted an analysis of the level of interaction of stakeholders. It was revealed that the low implementation of tourism development plans and the low level of interaction with stakeholders have a negative impact on the development of the tourism industry (Pjerotic, L., 2017). Attention is paid to the aspects of tourism of different age groups. In the article Grundey D., Vilutyte G., the possibility of influencing the development of tourism for people "50+" is considered. Green tourism is actively developing (Grundey D., Vilutyte G., 2012). The peculiarities of the behavior of consumers of this type of tourism and the factors that influence the decision making about the trip are determined by the importance of ecology in the human mind (Zinchenko A.I., 2011). At the heart of the development of international tourism are the following factors:

1. Economic growth and social progress not only lead to an increase in the number of business trips, but also trips with cognitive and recreational purposes.
2. Improvement of all modes of transport has reduced the price of a trip, which makes it possible to travel to a wider range of people.
3. Globalization processes have led to the development of international relations and cultural exchanges, which increases the desire of people to learn other cultures and features of life.
4. The increase in the volume and quality of services stimulated technological progress in the field of telecommunications, increased interest in visiting various countries and regions.

2. METHODOLOGY FOR STUDYING THE INDICATORS OF THE DEVELOPMENT OF THE TOURISM INDUSTRY

To determine the impact of factors on the level of development of tourism in the EU and Ukraine, a study was conducted using the SPSS program. To confirm the adequacy of the sample of factors, the Kaiser-Mayer-Olkin sample adequacy measure was calculated, the Bartlett coefficient was calculated. Also a factor analysis was carried out. The procedure for factor analysis involves a preliminary determination of the number of factors, because of which it is necessary to determine in advance their possible number. For this, the main component method and the graph of eigenvalues are used in the first stage. In the study, as a preliminary measure for determining the number of factors to be taken into account, a graph of eigenvalues was used. Correlation matrix of components is made. Based on this, the analysis is carried out using the principal component method. Orthogonal conversion by the varimax method is the most common way to maximize the spreading squares of the load for each factor. This leads to an increase in large and a decrease in small values of factor loads, which makes it possible to evaluate the results more uniquely. Visualize the clustering, which is carried out by the SPSS program using the Dendrogram (hierarchical tree). Teng Qiu and Yongjie Li noted in their work: "In the Dendrogram, all data points are represented by leaf nodes on the left side, each merge process is denoted by" \cap "-shaped connection, with two horizontal lines connecting the two combined clusters and the distance of its vertical line denoting dissimilarity between merged clusters. As the merger occurs, this hierarchical tree is nested from left to right. In the Dendrogram, some of the " \cap " -shaped relationships can be relatively right, indicating that the clusters associated with them If you cut off the references at a certain level or the threshold of dissimilarity, you can get several independent sub-dendrograms, each of which represents one cluster. Thus, leaf nodes in the same subendrograms are assigned in the same clusters. One of the advantages of Dendrogram is that all data instances (or leaf nodes) are explicitly located without overlapping "(Teng Qiu and Yongjie Li, 2017). Calculations were made on the basis of statistical data of the EU and Ukraine, presented on official websites of the statistical service of the European Union (Eurostat, 2018) and the State Statistics Service of Ukraine (State Statistics Service of Ukraine, 2018).

3. RESULTS OF THE STUDY OF THE DEVELOPMENT OF THE TOURISM INDUSTRY OF THE COUNTRIES OF THE EUROPEAN UNION AND UKRAINE

3.1. Influence of the level of development of tourism business on the economy of the country

The tourism industry in the modern period is one of the main factors creating additional jobs, accelerating the development of road and hotel construction, stimulating the production of all types of vehicles, contributing to the preservation of national culture and the identity of countries. In many European Union countries, tourism revenues have a significant share in the formation of the gross domestic product, the creation of additional jobs and the provision of employment, and the activation of the foreign trade balance. Tourism has a huge impact on key economic sectors such as transport and communications, construction, agriculture, production of consumer goods, and others. Thus, tourism should be considered one of the catalysts for socio-economic development. In turn, the development of tourism is affected by various factors: demographic, environmental, geographic, socio-economic, historical, religious, political and legal. The economic importance of tourism is confirmed by data on the world economic market (The World Bank, 2018). In Fig. 1 reflects revenues from international tourism of the countries of the European Union and Ukraine and their average annual growth rate for 3 years.

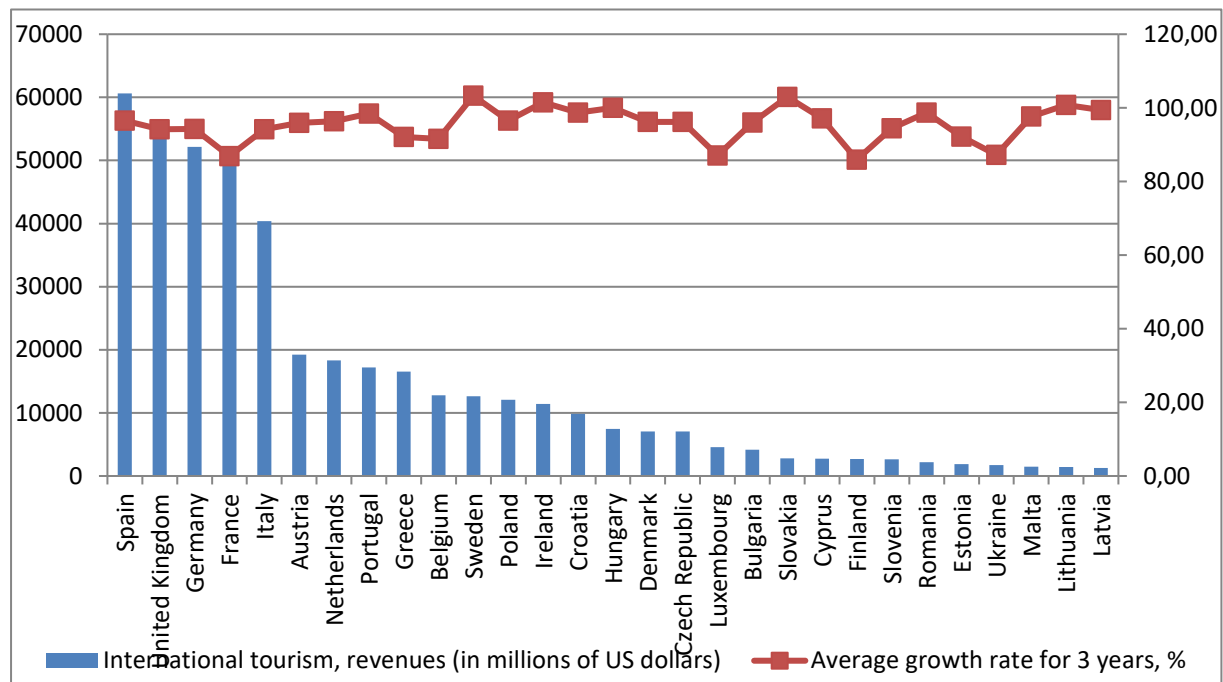

Figure 1: Revenues from international tourism and an average annual growth rate of 3 years (The World Development Indicators database (WDI) of the World Bank (2014)).

These data confirm that tourism is one of the most dynamically developing industries in many EU countries. Its role in the world economy is continuously growing. The potential of the tourism industry should be considered as an important component of the country's development. It is necessary to identify the factors that affect this industry.

3.2. Identifying the impact of factors on the development of the tourism industry

The presence of favorable factors leads to the leadership of individual countries in world tourism, and undesirable factors reduce the tourist flow. Among other things, it should be noted the importance of the material and technical factors that characterize the state and capabilities of the tourist industry base – accommodation, food, transport, recreation, trade, etc.

An important place in the sphere of tourism is allocated to enterprises of accommodation and food. The level of services provided in the hotel and restaurant industry significantly affects the attractiveness of the region for foreign tourists. To realize the tourist potential, the country must have a high-quality and extensive transport infrastructure, since the convenience and accessibility of movements within the country are of great importance. In this regard, for the study were chosen factors that reflect the level of the hotel and restaurant component of the tourism industry: number of establishments, number of bed places, nights spent by residents and non-residents, accommodation and food service activities, length of roads, length of railway tracks. Concerning the transport structure, only the length of the roads and length of the railway tracks is taken, because this is the most demanded transport for internal movements. Also, the need to include in the list of variables such factors as revenues from the international tourism and investment to tourism. Calculation of measures of sampling adequacy Kaiser-Meyer-Olkin and coefficient Bartlett is given in the table 1.

Table 1: KMO and Bartlett's Test

Kaiser-Meyer-Olkin Measure of Sampling Adequacy.		,672
Bartlett's Test of Sphericity	Approx. Chi-Square	251,338
	df	28
	Sig.	,000

In this study, the number of variables was chosen in such a way that the criterion is 0,672. Such a value, in accordance with the rule of interpretation of this criterion, shows an adequacy close to acceptable. The graph of eigenvalues is shown in the figure 2. Relying on the fact that there are only two components above the unit, we can make a preliminary conclusion that the number of factors that should be taken into account when performing factor analysis is two. Calculating the explained aggregate variance by using the Kaiser criterion, according to which the number of factors is equal to the number of components having eigenvalues greater than one, confirmed the need to take into account two factors. For the analysis, we can select only two factors, based on their values - 4,55 и 1,12. The first factor explains 57% of the total variance, the second - 14%, which is quite a high indicator. The process of composing the correlation matrix of components and its analysis by the principal component method showed the presence of two components. Both components are bipolar, since they have negative and positive correlation coefficients. The first component is accompanied by significant loads on such indicators:

- international tourism, revenues;
- number of establishments;
- number of bed places;
- nights spent by residents and non-residents;
- accommodation and food service activities;
- investment per person employed.

Figure following on the next page

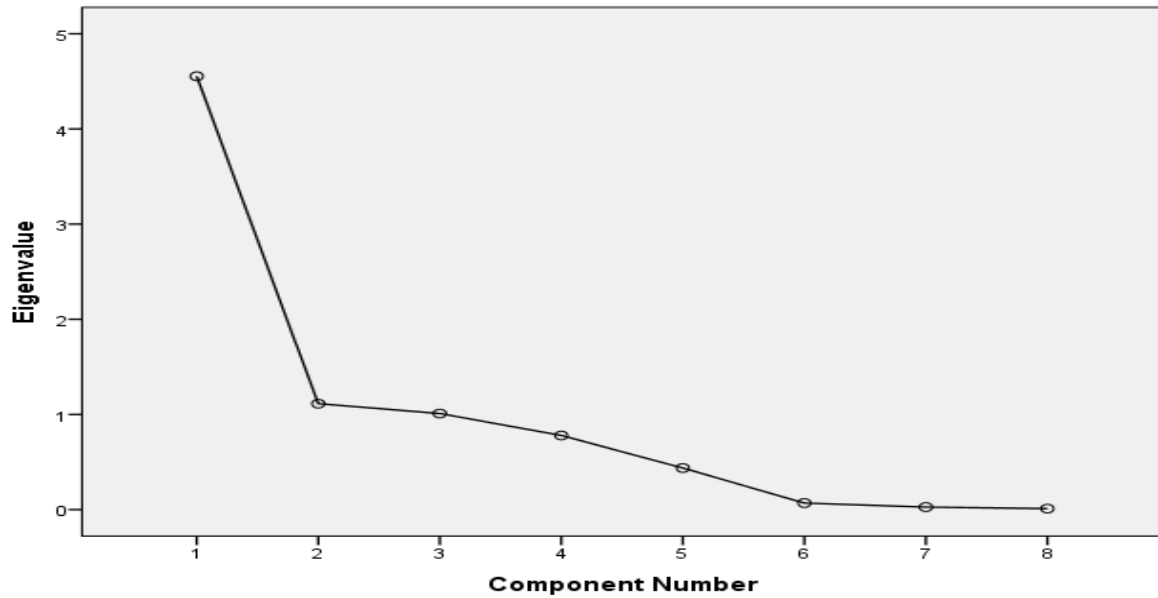

Figure 2: Scree Plot

The second component displays the load by length of roads and length of railway tracks. This load is lower than the load of the first component, but is large enough. The component diagram constructed after reversal by the varimax method is shown in figure 3.

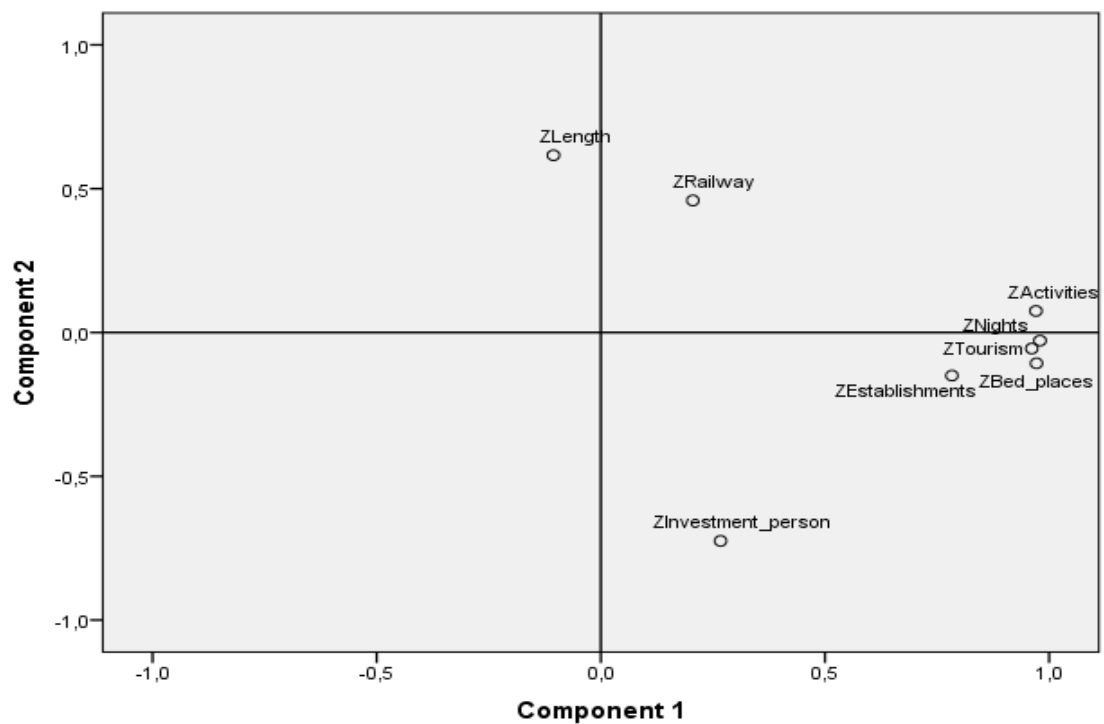

Figure 3: Component Plot in Rotated Space

The presented diagram shows the factor loads of both components. Approximation of variables to the axes and their distance from the reference point gives a more accurate interpretation of the factors, since in this case each variable confirms a significant load for one factor and

insignificant for another. This diagram confirms the earlier conclusions about the division of the ratio of variables considered in two components. The first component can be interpreted as the potential of the tourism industry - all variables included in this component directly characterize certain aspects of the tourism industry. The second component is the impact of transport infrastructure. The effect of the first component is higher, but the loads of the second component are also quite high. The influence of the first component is higher, but the loads of the second component are also quite high. Therefore, even with high results on the indicators of the first component, the position of the country among other countries can be worsened precisely under the influence of the state of the transport infrastructure. Thus, it can be concluded that for the successful development of the tourism industry, a qualitative and developed transport infrastructure is necessary. It is she who ensures the convenience of movement around the country, the accessibility of tourist areas. Accessibility of movement affects the level of cost of tourist tours for foreign tourists. When drawing up plans for the development of tourism in the country and its individual regions, the influence of the transport factor should be taken into account.

3.3. Segmentation of the EU countries and Ukraine on clusters, taking into account the development factors of the tourism industry

Using the factors on the basis of which the factor analysis was made, all the countries under consideration were grouped into clusters. Grouping into clusters was carried out with the purpose of revealing the interconnections within the clusters and the reasons for this separation. Following is a dendrogram of the results of running these data through the clustering algorithm (fig.4). Having examined the dendrogram, we can conclude that the most obvious is the division into four main clusters. The first cluster includes countries that can be attributed to the leaders in the tourism industry - Italy, Spain, United Kingdom and Germany. The listed countries have the highest indicators for the seven factors considered. The exception is the eighth factor - investment in tourism. On this indicator, the highest result among the leaders is in France, the lowest result - in Germany. Despite this, these leading countries have the highest level of income among all EU countries. Thus, factors of both components - the potential of the tourism industry and the transport infrastructure - have a positive impact on the indicators of the development of the tourism industry in the leading countries. The second cluster includes France. It should be noted that this country is very close to the leading countries of the European Union in terms of indicators considered. With the reduction in the number of clusters, France joins leading countries. France has the highest level of investment among all the countries under consideration, which in the future will guarantee the support of the tourism sector at a high level and its further improvement. Information support for international tourism is also enough. This is due to the fact that France is considered throughout the world a country of romance, fashion and beautiful architecture. The obtained results show that the component of the influence of the potential of the tourism industry is much higher than in other countries. The third cluster includes 21 countries in which the indicators are not high enough that these countries could be leaders in the tourism industry. At the same time, the combination of influencing factors gives a similar result, which allowed to unite these countries in one cluster. Hungary and Finland are remote from other countries in this cluster. In these countries, the indicators reviewed have a stable average level, which guarantees a relatively constant result. In general, it can be concluded that in these countries, the influence of the component factors does not have a single dynamics, which determines different results.

Figure following on the next page

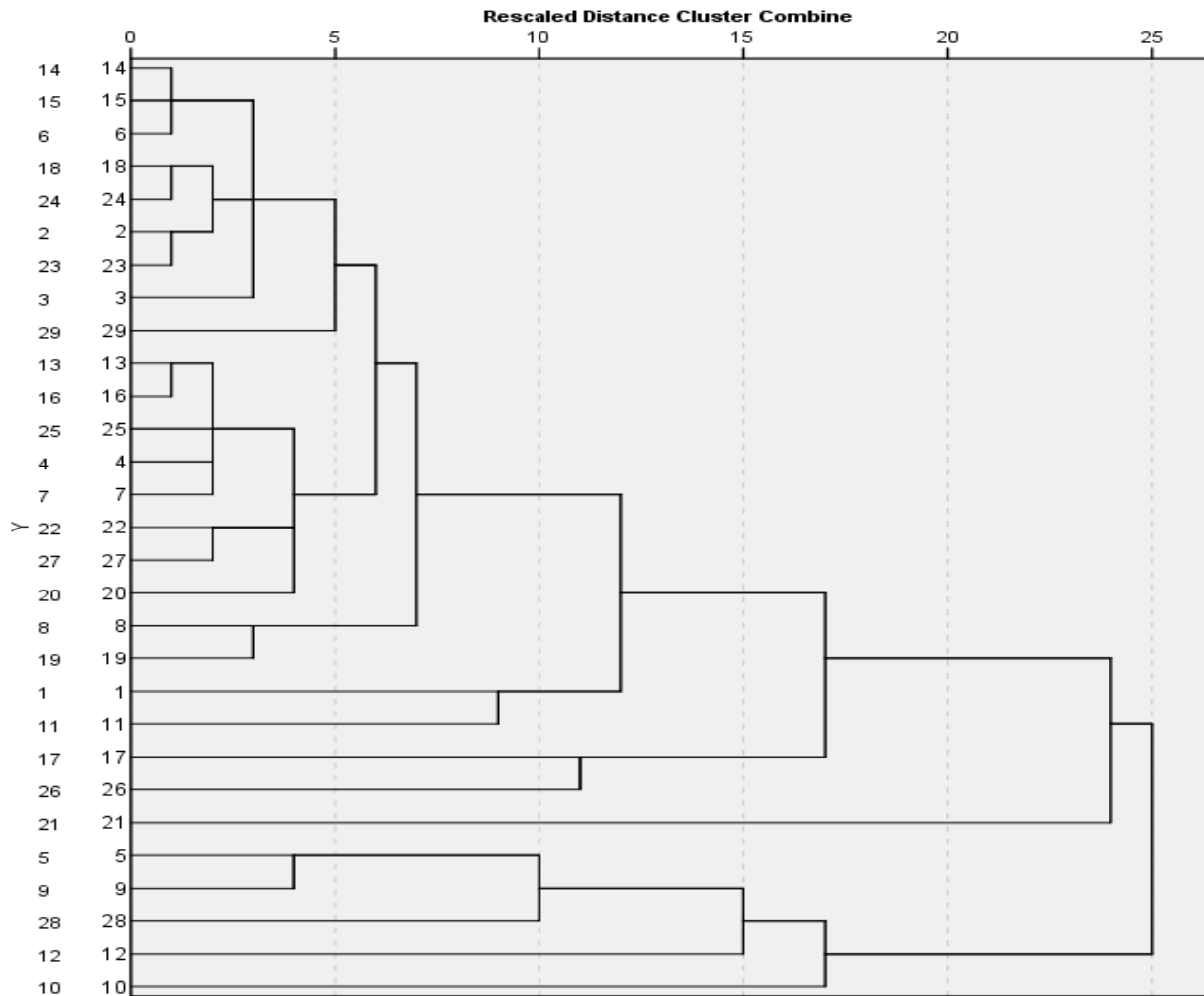

Figure 4: Dendrogram using Average Linkage (Between Groups)

The fourth cluster includes one country - Poland. According to the data of the constructed dendrogram, Poland is far from the countries of all clusters. This does not allow to annex Poland to any cluster. This country has fairly stable average positions for all factors considered. It should be noted two factors that distinguish it from most of the third cluster countries. In Poland, a fairly low level of investment in the tourism sector. But the development of the tourism industry in it is at a stable average level, which will allow you to earn income and jobs. The advantage of Poland is that it has a very long railroad and a rather long road. This fact contributes to the further development of tourism, eliminating the problem of providing transport. Influence of the transport infrastructure significantly improves the indicators of the first component, which led to the strengthening of Poland's position among other countries. The results of clustering taking into account the influencing factors are given in Table 2.

Table following on the next page

Table 2: The results of clustering and the peculiarities of the development of the tourism industry in the EU and Ukraine)

Clusters	Countries that are part of the cluster	Features of the development of tourism activities
Leaders	Germany, Spain, Italy, United Kingdom	The most comfortable conditions for the tourist business: sufficient investment, high revenues from the tourism industry, many hotels, good infrastructure
Aspiring to leaders	France	A significant number of tourist service facilities, a large flow of tourists, a highly developed transport infrastructure, a high level of investment in tourism
High realized potential	Poland	Most of the indicators are above the average, high employment in the tourism sector, high indicators of transport infrastructure
Average level of tourism potential use	Hungary, Finland	Hungary – constant indicators slightly above average, low level of investments Finland - constant indicators slightly below the average level, developed transport infrastructure
	Belgium, Bulgaria, Czech Republic, Croatia, Denmark, Estonia, Ireland, Cyprus, Latvia, Lithuania, Luxembourg, Malta, Portugal, Romania, Slovenia, Slovakia, Greece, Sweden, Netherlands, Austria, Ukraine	The presence of low indicators for individual factors, a wide scatter in the indicators of different factors

The results of the factor analysis, summarized in Table 2, revealed that the undisputed leaders in the development of the tourism industry are Germany, Spain, Italy, United Kingdom. This is facilitated by a high level of demand for services in this area, developed infrastructure, the availability of a sufficient number of accommodation and food. France is a separate cluster, as well as Poland. These countries have high indicators for all the factors studied, but their results are quite different from the leaders of this industry and from each other, which does not allow them to be combined into one cluster. The countries, united in a cluster of medium level tourism potential use, are divided into two blocks: Hungary, Finland are slightly higher than the average. This allows them to be classified as more actively upbuilding the potential of tourism. Some countries in the second block of this cluster show fairly effective indicators for the main factors. For example, the Netherlands, Austria and Czech Republic Countries have high rates of revenues from tourism, places of accommodation and food, demand for services, and employed personnel in this area. However, a low level of investment prevents the further development of the tourism business. The main problems in the development of the tourism industry should be recognized as a transport component, insufficient level of investment and information support.

4. CONSLUSION

Tourism is an important branch of the economy of any country, which is developing rapidly. The revenues from international tourism of the countries of the European Union and Ukraine have grown over the past 3 years. The study showed that there is a correlation between the level of tourism development and the country's security with the material and technical factors that characterize the state and capabilities of the tourist industry base. To realize the tourist potential, the country must have a sufficient number of accommodation and food establishments, as well as a high-quality and extensive transport infrastructure that ensures the convenience of

movement around the country and the availability of tourist areas. Clustering of the countries of the European Union and Ukraine on the main factors of the potential of the tourism industry has revealed their strengths and weaknesses that can be used to substantiate the directions for further development of the tourism industry.

LITERATURE:

1. Alla Ivashchenko, Nataliya Orlova «Comparative analysis of some EU member states and EU associated countries to identify the phenomenon of business development in post-socialist countries», *Economic Annals-XXI: Vol. 163, No 1-2(1), 2017, pp. 22-25*
2. Dainora Grundey, Gabriele Vilutyte “Development of the tourism sector in Lithuania: a focus on the 50+ sector”, *Journal of International Studies, Vol. 5, No 1, 2012, pp. 30-37.*
3. Eurostat (2018), Eurostat Structural Business Statistics (SBS), available at: <http://ec.europa.eu/eurostat/data/database> (Accessed 10 April 2018)
4. Gonza‘Lez, A.M., Rodri‘Guez, C., Miranda, M.R., Cervantes, M.. (2009), Cognitive age as a criterion explaining senior tourists’ motivations, in: *International Journal of Culture, Tourism and Hospitality Research, Vol. 3, No. 2, 200, p. 148-164.*
5. Grundey, D., Sarvutytė, M., Skirmantaitė, J. (2008), Prospects for Sustainable Tourism in Lithuania: A National Survey, in: *Transformations in Business & Economics, Vol. 7, No 1 (13), pp.21-51.*
6. Pjerotic, L. (2017). Stakeholder cooperation in implementation of the sustainable development concept: Montenegrin tourist destinations. *Journal of International Studies, 10(2), 148-157. doi:10.14254/2071-8330.2017/10-2/11*
7. Qiu, T.; Li, Y. IT-Dendrogram: A New Member of the In-Tree (IT) Clustering Family. Available online: <https://arxiv.org/abs/1507.08155> (accessed on 20 April 2017)
8. Seweryn, R., Niemczyk, A., Firlej, K. (2017), The Role of Social Media in an Assessment of the Factors of a Tourist Destinations Success. A Case Study of Cracow, *Economics and Sociology, Vol. 10, No. 2, pp. 252-266. DOI: 10.14254/2071-789X.2017/10-2/19* http://www.economics-sociology.eu/files/23_396_Seweryn_Niemczyk_Firlej.pdf
9. Shvets I.Yu. (2011), Spatio-regional clustering of tourist complex, *Marketing and management of innovations, 2011, № 2 p.65-73* http://mmi.fem.sumdu.edu.ua/sites/default/files/mmi2011_2_65_73_0.pdf
10. State Statistics Service of Ukraine (2018), Economic statistics, available at: <http://www.ukrstat.gov.ua> (Accessed 10 April 2018)
11. The World Bank (2018), World Development Indicators, available at: <https://data.worldbank.org> (Accessed 10 April 2018)
12. Zinchenko A.I., «The specialties of the behavior of green tourism’s consumer», *Marketing and management of innovations, 2011, № 3, T. 1, pp. 204-209* http://mmi.fem.sumdu.edu.ua/sites/default/files/mmi2011_3_1_212_217.pdf

THEORETICAL FOUNDATIONS OF SUBURBAN ZONE BOUNDARIES DEFINITION

Oliinyk V. D.

*Odessa State Academy of Civil Engineering and Architecture, Ukraine
v.oleynik7777@gmail.com*

ABSTRACT

The article examines the issue of determining the boundaries of the suburban zone, especially the suburban agriculture. Scientists and specialists, economists, geographers, demographers, town planners engaged in the theory and practice of forming suburban area, determining their boundaries, proposed different approaches, and therefore there is no generally recognized unified methodology and methods. In the article the approaches of scientists concerning the definition of the suburban area boundaries are analyzed: the radius of production and transportation of agricultural products, pendulum migrations, functional connections, the city as a center of gravity, the application of normative indicators, the location of suburban buildings and places for mass recreation of the population. Nowadays the issue remains relevant and open. To solve it, one should pay attention to the effectiveness of the ties between the city and the adjacent territory. The suburban area is formed under the influence of the city, its territory can be determined only on the basis of integrated accounting of functional ties with the city, the tightness and stability of these links, and the appointment of suburban space to meet the needs of the city. The main goal when allocating the border of the suburban area should be to consider it as a territory in the suburban space, which functions with the city as a whole. For this, it is necessary: to conduct a general analysis of the development of the territories surrounding the city, including the study of demography, economics, production, land use, ecology on the basis of statistical information; substantiation of factors and indicators affecting the emergence of ties between the city and the suburbs; the establishment of functions; the allocation of territories located in the zone of influence of the city; the definition of the border of the suburban area on the basis of complex zoning, which reflects the main functional connections.

Keywords: *border, suburban zone, connection, functions*

1. INTRODUCTION

Now it is well known that the city influences the development of suburban areas and forms a suburban zone. In fact, the larger the city (in terms of population), the greater its influence on the adjacent territory, which manifests itself in various functional connections: the formation of a recreation area; sanitary zone, formation of logistic infrastructure (warehouses, water supply, gas-pump stations, shopping centers), industrial and agricultural communications are traced. These relationships determine the various functions of the suburban area, their effectiveness, intensity (frequency of manifestation), and boundaries of distribution. A large number of studies of scientists is devoted precisely to determining the boundaries of the suburban zone [1, 2, 3]. In the period of 1930-40's - active industrialization, in 1950-70's - the growth of cities and agglomerations, the work of scientific geographers, economists were aimed at determining the territory (area) and composition of suburban areas.

2. COUNTRY AGRICULTURAL ZONE

The first works were devoted to the study of agricultural production around cities, the formation of suburban agricultural zones. The starting point is the work of the German economist I. Tünen "Isolated state in its relation to agriculture and national economy", later, the theory of the standard (location) was founded by V. Laungardt, the works of T. Palander and A. Weber, "The

Central Places Theory" by the German geographer W. Kristaller, the works of A. Lesch. The peculiarity of suburban agriculture was noted by economists, K. Marx, who wrote: «The faster the product spoils, the faster it should be used, and consequently sold after its production, the less distance from the place of its production, it can be distant... the more limited the market for its marketing» [4]. The growth of cities, the increase in the number of the urban population "required" from the suburban areas the production of low-transportable and perishable food products. The production of meat and dairy and fruit and vegetable products within the suburban area was caused, firstly, by an ever growing demand and secondly by the specific valuable properties of these food products and by the short terms of their storage and sale. By this principle, the radius of production of many products determines the boundaries of the suburban area. According to some scholars, suburban agricultural zones are special forms of specialization in agriculture. I. M. Koritko and S. D. Cheremushkin adhered to the principle of circles in the formation of suburban zones. In the first round, in their opinion, farms that produce vegetables, that is, low-transportable products should be placed. The size of this zone can be - 10-15 km. from the city. The second circle is "dairy" - 10-20 km. from the city. And the third enterprise is growing potatoes. The distance can be up to 50 km [5]. Along with the above argumentation of the food function of the suburbs, some economists in the 30's. The last century denied its independence. They believed that it was necessary to create not suburban zones, but zones for the delivery of food products to cities and industrial centers. Thus, M. I. Kubanin believed that the size of the territory of the suburban zone could be determined by one criterion, the distance to which agricultural enterprises deliver their products to the places of consumption, with the calculation of the return of vehicles to the farm on the same day. For potatoes, the suburban zone could range 40-45 km, for vegetables 20-25 km, for milk and other livestock products - 60 and 150 km, respectively [6]. However, with the development of technology, the notion of distance range has also been transformed, so it cannot be the determining criterion in determining the boundaries of suburban areas. A number of economists understand the essence and tasks of the suburban agricultural zone, which consists in ensuring the production of vegetables, potatoes, milk, diet eggs, fresh meat and poultry in sizes that meet the needs of the urban population. There is a need for a close location of farms to the city, the presence of a developed transport infrastructure. It is noted that the agricultural zone should include not specialized farms, but represent the territory of one or several administrative regions, the boundaries of which fix the size of the suburban agricultural zone [7]. By projecting these statements to date, given the mobility of transport, cooperation, the processing and storage of agricultural products, they are irrelevant. V. V. Pokshyshevsky also refuted the autonomy of the suburbs. He defined them as a territorial complex, the economic use of it is not of independent significance, but specialized only on servicing the city. To identify the suburban zone, that is, to determine its border, he suggests taking the norm of 150-700 square meters per capita [8]. Summarizing the above, we can draw the following conclusions:

- suburban areas, later suburban zones, prior to the period of industrialization and after it, were mainly considered as an agricultural component of the city;
- the productivity of the agricultural function of the suburbs was dictated by the population of the city;
- the boundaries of both the agricultural and suburban zones were determined by the distance (the point of the circle) to which agricultural enterprises deliver their produce to the sales points, with the condition of returning vehicles to the farm on the same day;
- the main function of the suburban area was agricultural;
- the suburban zone functionally fulfilled the "orders" of the city, "subordinated" to the city;
- the development of transport and scientific progress have made adjustments in the delineation of the suburbs.

3. ANALYSIS OF APPROACHES TO THE DETERMINATION OF THE BOUNDARIES OF THE SUBURBAN ZONE. Other theories (developments) are also traced in the question of determining the boundaries of the suburban area. A number of authors and collectives worked on problems of selection, planning, and development of the suburban zone. It should be noted the most significant works in this field of scientific research V. A. Vitman, A. G. Vishnevsky, V. G. Davidovich, V. A. Kamensky, S. A. Kovalev, G. M. Lappo, A. B. Naumova, V. M. Strunkovoy, N. A. Hauke, B. S. Khorev, M. G. Shapiro, and others. E. B. Alaev notes that practical problems, it becomes necessary to determine the boundaries of the gravitational zone, which manifests itself in various spheres: the place of application of labor, the place of study, the center of commerce, medical services, etc.) [9]. The scale of gravitation depends on a number of factors, among which the main ones are the attractiveness of the city center, determined by the spectrum, capacity and quality of the services provided, and the conditions of accessibility, expressed in the time required to visit it. In the opinion of V. A. Kamensky, M. Ye. Vaitens, N. A. Hauke, when determining the boundaries of a suburban zone, it is desirable to adhere to the existing administrative zoning of the territory, however, it is possible that, if necessary, it should be revised taking into account the factors of the influence of a large city [10]. A well-grounded approach to the definition of the territory of the suburban zone, which in the 1970s was formed into a separate scientific direction, is based on studying the pendulum migration of the population in the suburbs and its socio-economic aspects. Pendulum migration is understood as regular trips to a place of work or study beyond the limits of one's own settlement. An obligatory sign of a pendulum migration in the location of a permanent place of residence in one village, and the place of work or study is in another. This arrangement causes constant daily pendulum movements - stable in time and space [11]. Territorial movements can occur between different settlements within one or more administrative-territorial units. The interconnections of the city and the countryside are an important moment of the pendulum migration and the manifestation of urbanization. The proximity and accessibility of the city allows parts of rural residents to find work and study places in the city, without changing their place of residence. There is also a reverse trend of the pendulum movement of the population - from the city to the suburbs, as a rule, for the purpose of suburban recreation. Mass research related to the study of the constant and pendulum migration of the population in suburban areas was carried out in the 1960s and 1970s. Because of the study, the role of the pendulum migration in the settlement system was determined, the need for its study in the development of master plans for the development of large cities, schemes of district planning, the distribution of labor resources, and the formation of the labor balance of suburban agricultural enterprises was proved. Studies show that the boundaries of the suburban zone coincide with the boundary of the outer zone of the pendulum migration (attenuation of displacements: countryside - city, city - countryside). This limit is equal to the distance that cyclically (daily, seasonally) and constantly can overcome the population [12]. In addition, the connection of the city with the surrounding territory is not limited to daily trips to work, study of residents of the suburbs and urban residents - to places of rest. There is a tendency toward the city-center of other settlements, caused by the need for permanent cultural and social services. Particular importance in determining the boundaries of the city-district (according to M. Hauke) has the location of suburban buildings and places of mass recreation of the population. The population resettlement zone, which operates in the city, must necessarily be part of the city-district. At the same time, the possible range of population distribution when using railway transport is 30-35 km. The distance to the places of rest is determined individually in each individual case, and quantitative indicators should not be used [10]. M. Lappo argues that agglomerations are formed within the territory that the city can regard as its suburban zone and that is subject to its interests, and their borders are identical. The agglomeration zone includes the agglomeration core, the first belt of satellites, the second belt of satellites and the

peripheral zone [13]. Normative approaches to determining the size of the suburban zone are contained in the works of city planners, dealing with problems of urban development. In the design works on the regional planning of the suburban zones of the 50-60s of the 20th century, the following applied areas were used for a city with a population of 500 thousand inhabitants. The suburban area should be 700-800 thousand hectares, cities in 1 million inhabitants - up to 1 million hectares [14]. Urban planning is very important planning the suburbs of cities, as they perform a number of sanitary and hygienic, recreational, logistics infrastructure functions. According to town planning recommendations, the radius of the suburban zone is for a city with a population of more than 1 million - 35-50 km; 1-0.5 million - 25-30 km; 0.5-0.1 million. - 20-25 km [15]. The application of normative indicators cannot take into account the specific features of the city, the specifics of its surroundings. Most experts are convinced that in the issue of establishing the boundaries of the suburbs it is necessary to build on the functional ties of the city with the surrounding territories. However, the separate connections of the city with the suburban zone require their own areas and borders, which may not be intertwined. For agricultural products, obviously, there will be only borders for pendulum migration, for recreation - others. Nevertheless, most researchers agree that a suburban zone needs a single border, which includes the size of the suburban area or the area of the suburban area. This can be achieved on the basis of an integrated approach, which includes the zoning of the territory. There are a number of methods of zoning and zoning, which are used in the study of socio-economic phenomena:

- statistical groupings that allow identifying territorial units that are similar in a number of indicators;
- the theory of pattern recognition or the construction of a multidimensional mathematical model with homogeneous units (taxa)
- quantitative methods of studying space;
- determination of the Euclidean distance (remote coefficient)
- a characteristic of the mutual influence (attraction) of objects.

Zoning of the territory in order to determine the boundaries of the suburban area should be based on functional links and characteristics that distinguish suburban space. In this case, the application of an integrated approach to the formation of the border of the suburban zone, which cannot be found based on standard indicators, is correct - the suburban zone of each city is individual. Do not use distance, migration rate or population as a single criterion. This can lead to simplification and distortion of results. It is incorrect to limit the radius of the suburban strictly circular zone as a separate criterion, since the zone can spread in one direction or another, depending on transport networks, natural landscapes, and the established specialization of agricultural enterprises. In the issue of the need to include in the suburban area the existing administrative-territorial units between economists and designers there is a unity of opinions. The suburban area should be given the addressability and the possibility of centralized management, which will facilitate the administration of the territory of the zone, the quality of information support for the organization and improvement of the suburbs will be improved, since most of the statistical data (production reporting) is maintained within administrative units.

4. CONCLUSION

The suburban zone, of course, is formed under the influence of the city. Its territory can be determined only based on a comprehensive account of functional ties with the city, their effectiveness and sustainability, and also the destination of suburban space to meet the needs of the city (sanitary, recreational zones). Having considered the main theoretical developments in the question of determining the size of suburban zones, establishing their boundaries, we can

draw the following conclusions: the main objective in allocating a suburban zone should be to consider it as a territory in a suburban space that meets the needs of the city and operates with the city as a whole. To do this you need:

- conducting a general analysis of the development of the territories surrounding the city, including the study of demography, economics, production, land use, ecology on the basis of statistical information;
- selection and justification of factors and indicators that affect the emergence of functional relationships;
- establishment of functional links between the city and suburban areas;
- the allocation of territories located in the zone of influence of the city
- establishment of the border of the suburban zone based on complex zoning, which reflects the main functional links.

LITERATURE:

1. Alaev E. B., Social and economic geography: conceptual-terminological dictionary [Text] / E. B. Alaev. - Moscow: Mysl', 1983. - 350 p.
2. Cheremushkin S. D., Theory and practice of economic land valuation [Text] / S. D. Cheremushkin. - Moscow: Sotsekiz, 1963.- 237 p.
3. Davidovich V. G., Resettlement in industrial sites [Text] / V.G. Davydovich. - Moscow: Stroyizdat, 1962. - 216 p.
4. Davidovich V. G., Settlement in industrial centers [Text] / V.G. Davidovich. - M.: Stroyizdat, 1962 – 216 p.
5. Davidovich V. G., Settlement in industrial sites [Text] / V. G. Davydovich. - Moscow: Stroyizdat, 1962. - 216 p.
6. Hauke M. O., Suburban zone of a large city [Text] / M. O. Hauke. - Moscow: GSI, 1960.- 174 p., P. 47-48
7. Hauke M. O., Suburban zone of a large city [Text] / M. O. Hauke. -M.: GSI, 1960.-174 p.
8. Kamensky V. A., Suburban areas of large cities [Text] / V. A. Kamensky [and others] / ed. I. I. Fomina, B. V. Murav'ev. - L.: GSI, - 1963. - 149 p.
9. Khorev B. S., Problems of cities (Economic and geographical study of urban resettlement in the USSR) [Text] / B. S. Khorev. - M.: Mysl', 1971 - 413 p.
10. Khorev B. S., Problems of cities (Economic and geographical study of urban settlement in the USSR) [Text] / BS Horev. - Moscow: Mysl', 1971. - 413 p.
11. Kubanin M. I., Production types of collective farms. Process of growth of labor productivity in collective farming [Text] / M. I. Kubanin. Academy of Sciences of the USSR, -1936. - 477 p.
12. Lappo G..M., Geography of Cities [Text] / G. M. Lappo. - M.: VLADOS, 1997. - 480 p.
13. Marx K., Capital: Criticism of Political Economy [Text] / K. Marx, F. Engels. Op. - 2nd ed. T. 24 - M.: Politizdat, 1961 - P. 138-146 pp.
14. Pokshishevsky V. V., Population and geography: Theoretical essays [Text] / V. V. Pokshyshevsky. - M.: Mysl', 1978. - 315 p.
15. Yargina, Z. N., Fundamentals of the theory of urban development [Text] / Z. N. Yargina [and others] .- M., 1986. P. 103-105

KALININGRAD REGION AS A TOURIST GENERATING AREA FOR THE BALTIC SEA REGION

Tomasz Studzieniecki
Gdynia Maritime University
t.studzieniecki@wpit.am.gdynia.pl

Marzena Wanagos
Gdynia Maritime University
m.wanagos@wpit.am.gdynia.pl

Ilona Urbanyi-Popiolek
Gdynia Maritime University
i.urbanyi@wpit.am.gdynia.pl

ABSTRACT

Tourism is an important element and factor for macroregional integration in the Baltic Sea Region. On the initiative of the European Union, the EU Strategy for the Baltic Sea Region has been prepared and implemented. The Strategy recognises tourism as one of the priorities of development. Taking into account the fact that the Russian Federation is the only non-EU country located at the Baltic Sea, this country needs to be engaged in cooperation and macroregional exchange. Such cooperation is particularly important for the Russian Federation's oblasts situated at the Baltic Sea. It is reflected in the strategy documents of regional authorities. The stimulation of tourism exchange in the BSR is determined by a range of factors, among them a special role is played by the demand factor. The aim of this paper was to analyse Kaliningrad Oblast as a tourist-generating area for the Baltic Sea Region. For this purpose, relevant literature research and a critical analysis of legal documents have been conducted. Furthermore, a survey has been carried out among 110 randomly selected students of the Kant University in Kaliningrad. The survey enabled to identify tourist preferences among respondents, including the rank of BSR countries among the visited countries. The attractiveness of the countries in the Region has been analysed. Respondents indicated the strengths and weaknesses of Baltic destinations. This enabled to identify barriers and suggest ways to reduce them. A barrier to the development of outbound tourism is, first of all, visa problems and further financial problems. There is a need for improved transport accessibility, lower prices of transport services and more intensified marketing activities in the Russian Federation's market.

Keywords: *Baltic, destination, Kaliningrad, region, tourism*

1. INTRODUCTION

In the context of social and economic integration of the Baltic Sea Region, research on the determinants of tourism development within the Region should be conducted, taking into account the Baltic oblasts of the Russian Federation, because tourism is an element and a factor of such integration. However, most research on the tourist market focuses on inbound tourism since it contributes to the improvement of the balance of payments and the economic development of tourist reception areas. It is also worth examining tourist generating areas because outbound tourism has social and political impact and generates additional economic benefits through synergy with inbound tourism. Kaliningrad Oblast may become a tourist generating area for the Baltic countries provided that Kaliningrad Oblast's residents find these countries attractive and want to visit them.

2. LOCATION OF KALININGRAD OBLAST IN THE BALTIC SEA REGION

The Russian Federation comprises 85 independent subjects (administrative units), and 50 of them border other countries. One of these subjects is Kaliningrad Oblast (Fig. 1). Located in the southeastern part of the Baltic coast, this Oblast is the most westward oblast of the Russian Federation (RussiaTrek, 2018). It is part of the Northwestern Federal District (Moya strana, 2018).



Figure 1: Kaliningrad Oblast as a subject of the Russian Federation (own work based on Moya strana, 2018)

After the collapse of the USSR, the Oblast became a Russian enclave that borders Lithuania and Poland. In 2018 the Oblast, covering an area of 15,110 sq km, was populated by 995,000 people (Pravitelstvo Kaliningradskoy Oblasti, 2018). The location of Kaliningrad was and still is unique in terms of history, economy and geopolitics (Smith, 2007, p. 233). This former part of Prussia is now part of Russia and is separated from this country by 600 km (Palmowski, 2013, p. 26). It is much closer to Warsaw and Berlin than to Moscow. Due to its specific geopolitical location, the Oblast was once considered a Russian periphery and became a gateway to Russia for the European Union (Palmowski, 2013, p. 31). Following other Baltic countries (Miklinska, Klopot, 2016, p. 107), a special economic zone was opened (Mikhaylov, Gumenuk, Mikhaylova, 2016, p. 125, Studzieniecki, Palmowski, Korneevets, 2017, p. 772). The border crossings have been modernised. The Oblast's transport accessibility is slowly getting better (Mikhaylov, Gumenuk, Mikhaylova, 2016, p. 125, Studzieniecki, Palmowski, Korneevets, 2017, p. 772) (Fig. 2).

Figure following on the next page

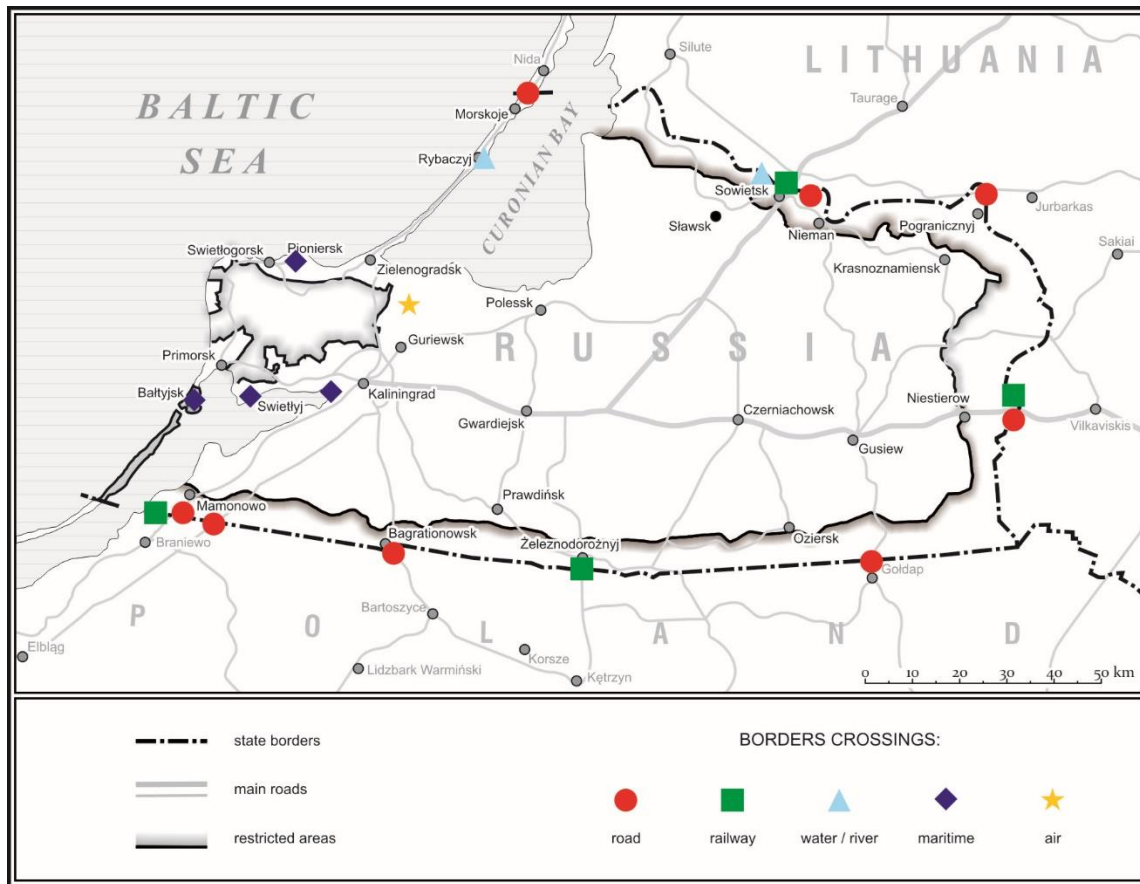

Figure 2: Location of Kaliningrad Oblast (own work)

Although the Oblast's social and economic conditions were poorer as compared to other Baltic countries (Gumenuk, 2017, p. 47, Wanagos, Smalec, Małachowski, 2017, p. 700), the Oblast is catching up fast. The enlargement of the European Union through the accession of Poland and the Baltic Republics in 2004 changed geopolitical relations in Baltic Europe. It was necessary to develop a new model of cooperation between Russia and the EU, including countries located at the Baltic Sea. There are strong connections between Kaliningrad Oblast and the Baltic Sea Region (Mouritzen, 2009, p. 2; Fedorov, 2010, p. 4). The implementation of the EU Strategy for the Baltic Sea Region became an opportunity for Kaliningrad Oblast to join the process of Baltic integration to a greater extent (Anisiewicz, Palmowski, 2016, p. 25). Tourism has become an important factor and element of this integration (Skrzeszewska, Grobelna, 2017, p. 525; Semenova, Zaitseva, Korneevets, 2017, p. 1555). Kaliningrad Oblast has become a new tourist reception and tourist generating area for the BSR countries. Based on an analysis of the tourist market (Semenova Zaitseva, Korneevets 2017, p. 1556), tourist products could be created (Smalec, 2014, p. 295). But it must be pointed out that despite the implementation of these activities, Kaliningrad Oblast has the poorest network of transport connections as compared to other BSR countries (Studzeniecki, Palmowski, Korneevets, 2017, p. 772). This creates a barrier both to the development of inbound tourism and outbound tourism. The EU visa formalities make it very hard for Russians to develop outbound tourism. An experiment in the form of visa-free traffic for trips between Poland and Russia under the "local visa traffic" failed because Poland withdrew from this agreement.

3. TOURIST SYSTEM OF THE BALTIC SEA REGION

The tourist system is a term that is used often and differently in the theory of tourism (Lohman, Netto, 2016, p. 5). Many authors use the classic concept of the tourist system, where an area

can perform three functions simultaneously: the function of a tourist generating area, a tourist reception area, and a transit area (Kizielewicz, 2016, p. 125, Zemla, 2016, p. 2, Antosova, Arias Gomez, 2014, p. 39, Meyer, 2017, p. 365). In the spatial approach, the tourist system analysed in this paper covers the Baltic Sea Region. It is postulated (Klemeshev, Korneevets, Palmowski 2017, p. 4) that the Baltic Sea Region should be defined by using three circles, depending on the aim of delimitation. But there is no agreement on the borders of the circles. According to the authors, the first circle comprises NUTS 2 regions located directly at the Baltic Sea, the second circle covers areas of EU cross-border programmes, and the third circle covers a soft security zone (Fig. 3).



Figure 3: Triple delimitation of the Baltic Sea Region (own work)

For the purposes of this paper, a modified version of the first circle has been adopted. The NUTS 2 coastal regions that could be found in the first circle were replaced by the Baltic countries. Only in the case of the Russian Federation two oblasts were added to the BSR: Kaliningrad Oblast and Leningrad Oblast. Changes also affected Poland and Germany. These countries were added to the BSR entirely. The BSR delimited in this way becomes a reception area, and Kaliningrad Oblast becomes a tourist generating area (Fig. 4).

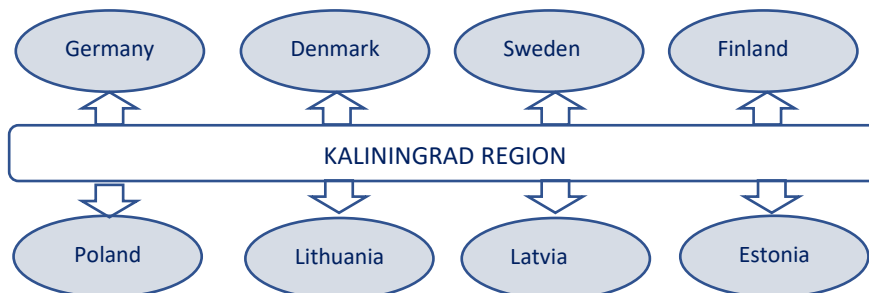

Figure 4: Kaliningrad Oblast as a tourist generating area for the Baltic Sea Region (own work)

In Kaliningrad Oblast, five BSR countries have their consular representations (Ministry of Foreign Affairs, 2018): Germany, Denmark, Latvia, Lithuania and Poland. The functioning of these posts may be a factor increasing tourist traffic to these countries from the Oblast, provided that these countries launch promotional activities.

4. BALTIC SEA REGION IN VIEW OF A SURVEY

In 2017 a survey was conducted among 110 randomly selected employees and students of the Immanuel Kant Baltic Federal University in Kaliningrad. The first question aimed to determine the tourist preferences of respondents. Respondents were asked about the countries they would like to visit as tourists.

Almost all participants chose European countries. It is significant that the first two places are taken by the BSR countries: Germany and Sweden. None of the respondents chose the Baltic Republics (Fig. 5).

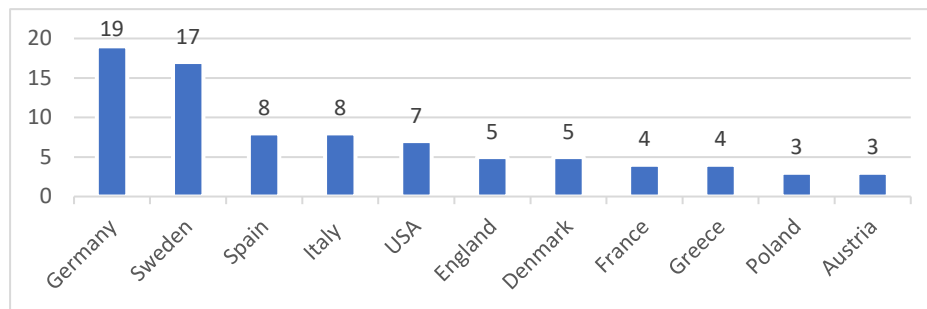

Figure 5: Countries that respondents would like to visit as tourists

In the second question respondents were asked about the BSR countries they have already visited. The vast majority of the respondents have visited neighbouring countries, i.e. Poland and Lithuania. Germany ranked first among countries that do not border Kaliningrad Oblast. One may assume that the high rank of Poland may result from the fact that Poland is a transit country. The Scandinavian countries were the least visited by respondents (Fig. 6).

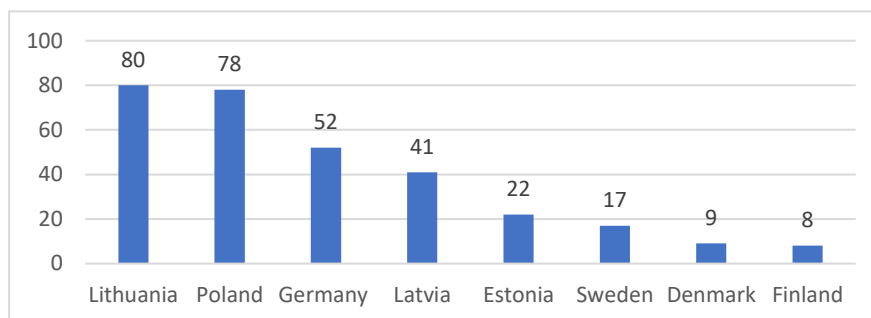

Figure 6: BSR countries already visited by respondents (own work)

In the third question respondents indicated in which countries they have relatives or friends. The largest number of respondents have relatives or friends in Germany, followed by Lithuania and Latvia. The Scandinavian countries and Estonia were ranked the lowest (Fig.7).

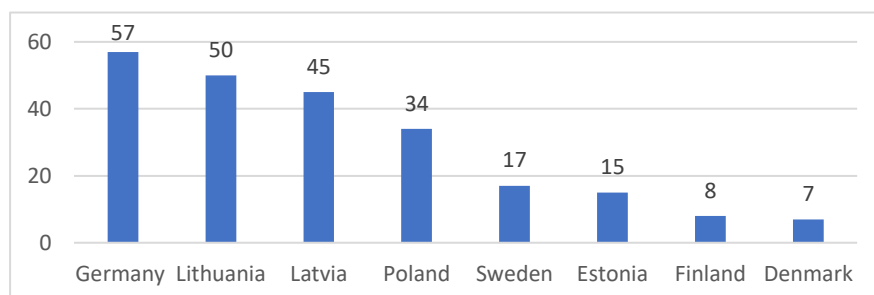

Figure 7: BSR countries in which respondents have relatives or friends

The next question concerned the tourist attractiveness of BSR countries. The unquestioned leader was Germany. The high rank of Germany may result from the fact that many Russians have visited Germany and know that country. Germany was followed by the Scandinavian countries, including Sweden. The countries of Eastern Europe were considered the least attractive (Fig.8).

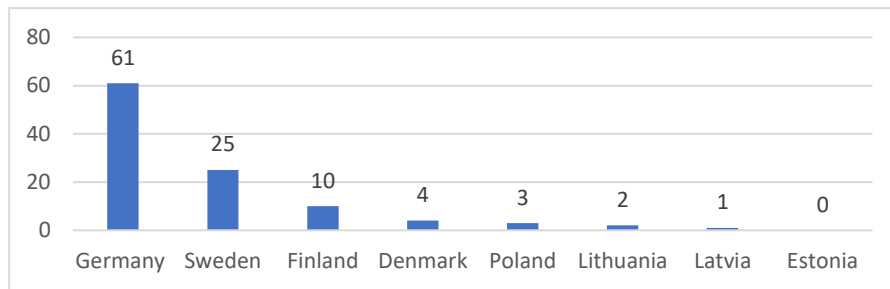

Figure 8: BSR countries considered attractive (own work)

Regardless of how the BSR countries were assessed in terms of their attractiveness, respondents were asked to indicate three BSR countries that they would like to visit most. The country which was indicated first was given 3 points, the country indicated second – 2 points, and the country indicated third – 1 point. Taking into account only the number of indications (excluding points), we may note that more than half of the respondents indicated the Scandinavian countries and Germany. It should be stressed that there is a great disproportion between Eastern Europe and other BSR countries (Fig.9).

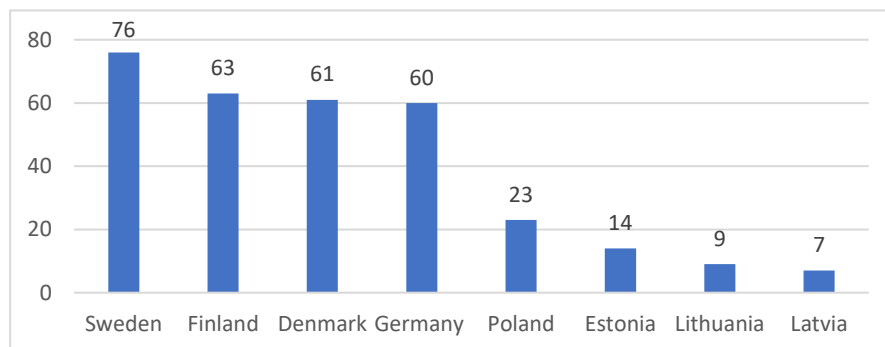

Figure 9: BSR countries that respondents would like to visit, excluding the order of visits (own work)

Taking into account the number of points given to three countries indicated by respondents, the ranking of these countries slightly changed. Sweden still remained the leader, but Germany overtook Denmark and Finland (Fig.10).

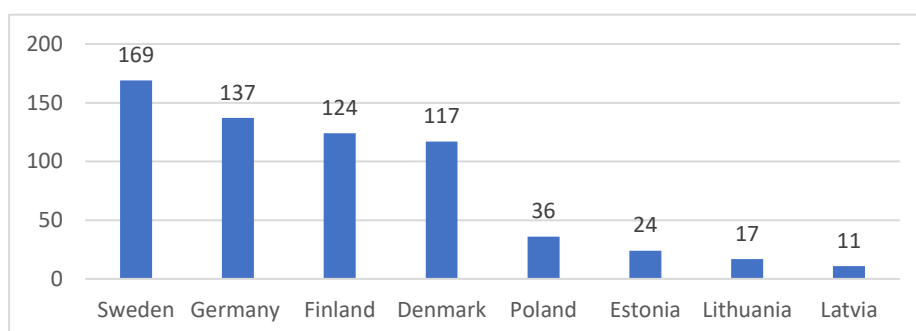

Figure 10: BSR countries that respondents would like to visit, including the order of visits (own work)

Respondents were also asked to assess the selected elements of the tourist attractiveness of the entire BSR (from the worst to the best). In all cases there are more positive and very good indications than bad and very bad ones. Out of all elements, natural and cultural assets were assessed the best, and prices of services were assessed the worst (Tab 1).

Table 1: Assessment of the elements of BSR tourist attractiveness (own work)

Elements of attractiveness	Very bad	Bad	Average	Good	Very good	I have no opinion
Accessibility	1	8	50	32	18	2
Prices of services	5	18	50	28	2	6
Nature			5	35	67	1
Culture			8	44	55	1
Entertainment		3	21	39	36	11

The final question about barriers to outbound tourism in the BSR was open. The survey has shown that visa and financial barriers are the most significant. The barriers include political issues, also Russophobia. The border-related barriers include, above all, the suspension of local border traffic between Poland and Russia (Fig.11).

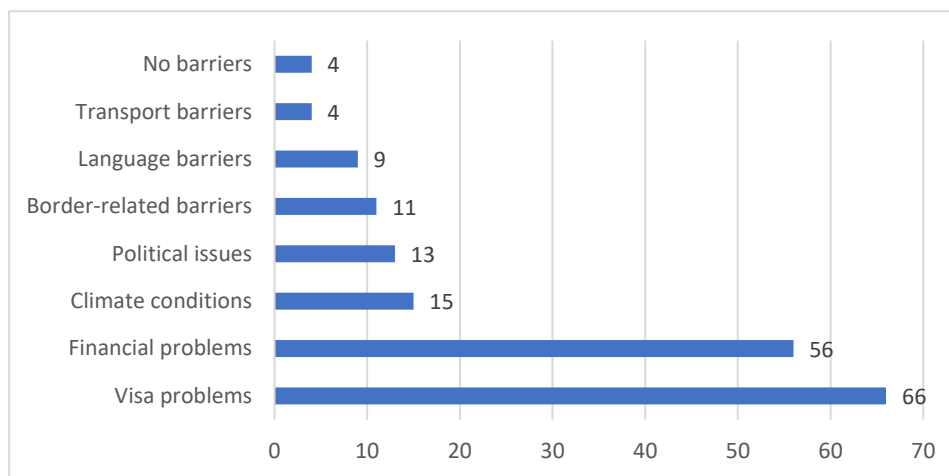
*Figure 11: Barriers to tourist visits in the BSR countries*

5. CONCLUSION

Kaliningrad Oblast occupies a significant position in the Baltic Sea Region. The authorities of the Oblast undertake activities to improve the Oblast's position in the BSR. By supporting the development of inbound tourism and at the same time by improving transport accessibility, the authorities facilitate the development of outbound tourism. This is done through the strengthening of international relations, both official and interpersonal ones. Most Baltic countries have consular posts in the Oblast. Kaliningrad Oblast's residents most frequently visit neighbouring countries, i.e. Poland and Lithuania. The Baltic Sea Region is considered attractive in terms of culture and nature. But the development of outbound tourism is hindered by financial and visa barriers. The assessment of transport accessibility varies greatly. The Baltic Sea Region is not a homogeneous whole for respondents. It can be divided into two subregions. The first, covering the Scandinavian countries, is rarely visited but considered more attractive. The second, covering the Baltic Republics and Poland, is visited more frequently, but it is much less attractive according to respondents. Respondents were interested in visiting these countries to a small extent. The survey has shown an important role of Germany as an area of tourist reception. The largest number of respondents have relatives and friends there. Germany was considered the most attractive country for tourists. It was Germany that was indicated by the majority of respondents in the open question about the countries that respondents would like to visit as tourists. The million people living in Kaliningrad are a tourist potential for the BSR countries. It is worth using this potential by creating tourist products and by intensifying promotional activities.

LITERATURE:

1. Anisiewicz, R., Palmowski, T. (2016). Współpraca Polski z Obwodem Kaliningradzkim Federacji Rosyjskiej jako istotny element integracji bałtyckiej. In *Prace i Studia Geograficzne* vol. 61(1), pp. 23-28. Warszawa: Uniwersytet Warszawski.
2. Antosova, A., Arias Gomez HY. (2014). The region of Liberec as tourist destination: an analysis of case in the Czech Republic. In *Cuadernos de Desarrollo Rural*, vol. 11, issue 73, pp. 39-59.
3. Fedorov, G. (2010). Strategies for the development of the Baltic Region. In *Baltic Region* vol. 2. Kaliningrad: Immanuel Kant Baltic Federal University.
4. Gumenuk, I. (2017). Human development index as a tool to assess social development in the Baltic States. In *Baltic Region* vol. 3, pp. 45-57. Kaliningrad: Immanuel Kant Baltic Federal University.
5. Kizielewicz, J. (2016). Regional Experiences in the Management Development of Cruise Ship Ports in Coastal Destinations. In F. Pinzaru, C. Bratianu (eds.) *Conference Proceedings of the 12th European Conference on Management, Leadership and Governance (ECMLG)*, pp. 125-132. Bucharest: ACAD Conferences Ltd.
6. Klemeshev, AP, Korneevets, VS., Palmowski, T., et. al. (2017). Approaches to the definition of the Baltic sea region. In *Baltic Region*, issue 4, pp. 4-20.
7. Lohmann G., Netto A. (2016). *Tourism Theory: Concepts, Models and Systems*. Boston: CABI
8. Meyer, B. (2017). Creating tourist space on the basis of natural environment as an element of sustainable development, case of the Stepnica commune. In *Conference Proceedings of the 4th International Scientific Conference on ToSEE - Tourism in Southern and Eastern Europe*, vol. 4 pp. 365-375. Opatija: University of Rijeka.
9. Mikhaylov, AS. Gumenuk, IS., Mikhaylova, AA. (2016). Russian public transport system: the customers' feedback on the service provision. In *Public Transport*, Vol. 8 Issue 1, pp. 125-141.
10. Miklinska, J., Klopott, M. (2016). Special economic zones as an instrument of regional development support - experiences from Poland. In AM. Tonkovic (ed.), *Medunarodni Znanstveni Simpozij Gospodarstvo Istocne Hrvatske-Jucer Danas Sutra*, pp. 943-951. Osijek: University of Osijek.
11. Ministry of Foreign Affairs (2018). Retrieved 16.05.2018 from https://kaliningrad.mid.ru/web/kaliningrad_en/diplomatic-corps-in-kaliningrad.
12. Mouritzen, H. (2009). *Russia as key to the Baltic Sea region*. Copenhagen: Danish Institute for international Studies.
13. Moya strana (2018). Retrieved 16.05.2018 from http://kcbux.ru/Statyy/ZA_zizny/za-016_karta-RF.html.
14. Palmowski, T. (2013). *Kalinnigrad – szansa czy zagrozenie dla Europy Bałtyckiej*, Gdańsk-Pelplin: Uniwersytet Gdański.
15. Pravitelstvo Kaliningradskoy Oblasti (2018). Retrieved 16.05.2018 from <https://gov39.ru/region>.
16. RussiaTrek (2018). Retrieved 16.05.2018 from <http://russiatrek.org/kaliningrad-oblast>.
17. Semenova, LV., Zaitseva, NA., Korneevets, VS. (2017). Ensuring the Competitiveness of the Tourist Product of the Kaliningrad Region as Part of the Strategy Cross-Border Cooperation. In *Eurasian Journal of Analytical Chemistry*, Vol.12, Issue: 7B, pp. 1555-1562.
18. Skrzyszewska, K., Grobelna, A. (2017). The possibility of overcoming seasonality of Polish coastal tourism - the case of the Pomorskie voivodship. In S. Markovic, DS. Jurdana (ed.), *Tourism in South East Europe*, vol. 3, pp. 525-539. Opatija: University of Rijeka.

19. Smalec, A. (2014). Trade shows and exhibitions as a form of promotion of regional, local and traditional products. In G. Mazure (ed.), *Economic science for rural development: marketing and sustainable consumption - rural development and entrepreneurship - home economics*, pp. 43-51. Jelgava: Latvian University of Agriculture.
20. Smith, RA. (2013). The Kaliningrad region: Applications of the civic and ethnic models of nationhood. In *Journal of Baltic Studies*, Volume 24, Issue 3, pp. 233-246. Abingdon: Taylor & Francis Group.
21. Studzieniecki, T., Palmowski, T., Korneevets, V. (2017). The tourism accessibility of the Kaliningrad region in Baltic Europe. In V. Klimova, V. Zitek (eds.) *Conference Proceedings of the 20th International Colloquium on Regional Sciences*, pp. 772-779. Brno: Masaryk University.
22. Wanagos, W., Smalec, A., Małachowski, K. (2017). Local government activities relating to local entrepreneurship by tourism entities in the Pomeranian voivodeship. In V. Klimova, V. Zitek (eds.) *Conference Proceedings of the 20th International Colloquium on Regional Sciences*, pp. 700-706. Brno: Masaryk University.
23. Zemla, M. (2016). Tourism destination: The networking approach. In *Moravian Geographical Reports*. Vol. 24, pp. 2-14.

SYNTHESIS OF PEDAGOGICAL AND TECHNICAL EDUCATION: VECTORS OF DEVELOPMENT LEAN-EDUCATION

Svitlana Yermakova

*Odessa State Academy of Civil Engineering and Architecture, Ukraine
ermakova.s2011@yandex.ua*

ABSTRACT

Management of educational innovation in the process of creating the result of training of future professionals is a kind of paradoxical process. On the one hand, a modern higher education institution should be stable in its individuality and educational strategies, and on the other hand, open to constant changes. The mentioned format of educational issues is especially relevant for Ukraine too, in particular, in the context of synthesis of pedagogical and technical education. In the paradigm of solving this problem, the idea of managing education and knowledge becomes actual, namely, the idea of prudence and providence concerning the use of educational process opportunities of a higher technical educational institution on the basis of lean-education. Innovativeness as the dominant principle of the pedagogical system of a higher technical educational institution reflects the results of applying the best world achievements. The pre-condition for productivity of its implementation in current complex socio-economic conditions is the correspondence of the personal and professional level of modern teachers at higher educational institutions to the requirements of time. The use of lean-thinking using the means of a higher educational institution actualizes the educational resources of a technical higher educational institution in general and its teachers in particular, promotes the transformation of knowledge and actions into result, gradually reduces losses at all stages of creating educational values, and, as a result, raises its competitiveness. The integration of lean-thinking in Ukrainian higher technical education will help to determine the ways of forming social vectors for the synthesis of pedagogical and technical education. Thus, there is a need to rethink the goals and essence of the activities of modern teachers of higher technical educational institutions and their monitoring as a content core of activities on the basis of prudence and providence as to the use of possibilities of educational process of a higher technical educational institution. That is why the lean use of resources of a higher technical educational institution in implementation of the experimental lean-technology of occupational training of future specialists is specified and the pedagogical practicability of the advanced training of future specialists is proved in the research. Therefore, lean-education today is a new educational reality which determines the absolutely innovative structure of the latest educational products and educational services, and their high competitiveness. Formation of lean-culture is the necessary component for the training of the new formation specialists who are competitive to the challenges of the modern world.

Keywords: *didactic integration, higher education institution, individual educational route, kaizen direction, lean-education, lean-production of knowledge, lean-technology, lean-thinking, occupational training, teacher of higher technical educational institution*

1. INTRODUCTION

The reorientation of the post-industrial society to information and knowledge as strategic resources of development led to radical transformations in the contemporary worldview. In the current conditions, the tendency to strengthen the relationship between science, education and production has acquired clear contours. Science is turning more and more into the immediate productive power of society, and its impact on social progress and economic growth is increasing. Thus, the change in the very paradigm of human progress, the essence, and the basic measure occurs, and the formation of a system of lean-transformations becomes its main

criterion on the basis of the growth of transformational processes and the transition to the science and information technology. The defining values of the system of lean-transformations are knowledge and ability of a person to study throughout life (Voronin M., 2006). In turn, in a knowledge society, the lean-education is gaining a special social force, since it is actualized on the basis of prudence and providence using the opportunities of educational process. Socio-economic realities assign fundamentally new tasks for lean-education and offer new opportunities. The paradigm of lean-education, which is based on the principle to form an "educated human," cannot function fruitfully within the old socio-economic forms. The modern world needs a competitive specialist able to operate in conditions of socio-economic transformations possessing a constantly functioning innovative component. That is why the educational process of higher technical educational institutions can be equated to production, where the "product" is a future specialist who is given additional "value" in the form of knowledge, skills and the level of the formed competencies. In the context of solving this problem, the issue of introducing lean-education in higher technical education institutions becomes actual.

2. THEORETICAL AND METHODOLOGICAL SUBSTANTIATION OF SCIENTIFIC KNOWLEDGE OF OCCUPATIONAL TRAINING OF FUTURE SPECIALISTS IN MODERN HIGHER TECHNICAL EDUCATIONAL INSTITUTION ON BASIS OF LEAN-EDUCATION

The priorities of the state policy in the field of higher technical education lie in the plane of creating the preconditions for advanced occupational training of the creative personality of a future specialist, providing opportunities for mastering the professional qualification and competence, which will enable the future specialist to build a trajectory of own personal and professional growth (Yevtukh M.B., Voloshchuk I.S., 2008). Thus, studying the state of occupational training of future specialists in higher technical educational institutions is possible at several levels of methodological analysis (Yermakova S.S., 2009): the first level is carried out on the basis of general philosophical understanding of the cognition and self-cognition problem, the main means of which is development; the second one is argued by the choice and substantiation of the methodological foundations for the study of occupational training of future specialists in a higher technical educational institution, and the third level is specified by the definition of methods for a monitoring research of the readiness formation state of future specialists in a higher technical educational institution for professional activities, which includes the development of a monitoring technology for occupational training in accordance with the determined methodological provisions, taking into account the peculiarities of their professional development.

2.1. Methodological Concepts of Research

The strategy of deploying the process of research of the occupational training of future professionals in a higher technical educational institution on the basis of lean-education is based on three interrelated concepts (Yermakova S.S., 2010):

- The methodological concept reproduces the interconnection and interaction of scientific approaches (personally oriented, personally active, systemic) concerning the study of the monitoring problem of occupational training of future specialists with the competence paradigm as a dominant idea which enables to develop a general scientific understanding of the occupational training of future specialists in higher technical educational institutions considering the interpretation of key competence rescripts ("knowledge in action", "knowledge of activity methods", "procedural knowledge").
- The theoretical concept defines the system of initial parameters, definitions, assessments without which it is impossible to scientifically explain the process peculiarities of the

occupational training of future specialists in a higher technical educational institution on the basis of lean-education, its specific functions and characteristics. The essence and theoretical foundations of monitoring support for the occupational training of future specialists are revealed through the triad of characteristics of educational and occupational activities (purpose, means, result). On that ground, the theoretical basis of the monitoring paradigm as the special subsystem of occupational training of future specialists is considered.

- The technological concept represents monitoring of occupational training as a pedagogical tool for managing productive occupational training of future specialists. The experimental monitoring technology for the training of future specialists is based on a theoretically substantiated set of necessary and sufficient pedagogical conditions.

Due to pedagogically balanced monitoring of occupational training, the advancing occupational training of future specialists involves: optimization of organizational and managerial structures, mobility of means for realization of educational functions, systematic introduction of the up-to-date information technologies; the initiation of interactive forms and methods of control, the focus on auxiliary, advanced control, the shift of emphasis to the end result, records of effectiveness of the educational process in a higher technical educational institution and the economical use of its capabilities; this adds salience to the signs of openness and democracy.

2.2. Conceptual Framework and Research Categories

Nowadays Ukraine is experiencing a unique moment in history: innovative technical technologies coupled with modernization and investments in higher technical education provide the opportunity for radical economic acceleration. A significant factor in maintaining the quality of higher technical education is the productive occupational training of future specialists implemented on the basis of economical use of opportunities of the educational process of a higher technical educational institution, and the creation of a monitoring technology for their occupational training. The occupational and educational interests of scientists form the market demand for continuous higher technical education of different levels and character. The modern technical university is a specific higher educational institution with a wide range of faculties and departments as well as a set of research and educational institutes, affiliates and centres, small research, consulting and production firms, colleges and specialized schools (Larionova M.V., 2006). The criterion of classification is not the quality of the occupational training or the number of students, but the prognostic performance of the structure, which represents both the corresponding intellectual level of the staff and the combination of fundamental and applied scientific schools (Mikhailichev Ye.A., 2002). A rational decision on the development of the system of occupational training for future specialists is the introduction of lean-technology in the process of their occupational training (Baidenko V.I., 2001; Bykov V.Yu, 2005): "economical education", "drawing" education, visual monitoring, kaizen (terms of lean-education), etc. Implementing lean-technologies in the process of occupational training in a higher technical education institution is a specific investment both in the development of innovative educational technologies and in the process of forming competitive specialists (Byshenko D., 2007). In addition, occupational training, its goals, objectives, and content are motivated to ensure the achievement of the highest quality of occupational training of a specialist (Vader M., 2007). Implementation of the educational process under the changing socio-pedagogical conditions is possible only on the basis of taking into account the effectiveness of the educational process and the economical use of its capabilities. Such an integrated educational and scientific system is mostly understood by scholars (Klarin M.V., 1996, etc.) as the "prudent" occupational training of future professionals, which is a combination of European functionalism and Eastern philosophy.

Thus, due to the experience of Toyota (Ono T., 2012) and the interpretation of its ideas of "prudent production" in various fields of life, lean-education today is appropriate to be considered as the most productive, reliable, economical way to overcome the crisis, to increase the competitiveness of higher technical educational institutions. It is also considered to be essential that continuous technical education is an integral dynamic social and pedagogical system which quality monitoring requires an innovative approach that is "directed" to the person who becomes its centre and an active participant. Summarizing the analysis conducted, we conclude that the productive training of future specialists involves the selection of such key research categories:

- diversification of occupational readiness of future specialist;
- providing pedagogical innovations in the process of forming the readiness of future professionals for occupational activity;
- interactive didactic means of advanced occupational training of creative personality of future specialist;
- positive communication in the subsystem "teacher-scientist - future specialist".

Therefore, the occupational training of future specialists in the context of the idea of continuous education on the basis of "economical" production of knowledge is the system of continuous effectiveness monitoring for the educational process and the economical use of its capabilities at a higher technical educational institution as the dominant idea of occupational training for future engineers aimed at continuous improvement. In the context of the aforementioned, the fundamental change of the humanitarian dominant of higher technical education, its orientation to universal values and the intellectual wealth of humanity direct a modern teacher of a higher technical educational institution at the formation of a future engineer complying with the requirements of the present and, in turn, impose requirements for the personality of a specialist in the world.

3. PHENOMENOLOGY OF MONITORING IN THE SYSTEM OF QUALITY OF OCCUPATIONAL TRAINING OF FUTURE SPECIALISTS ON BASIS OF LEAN-EDUCATION

Modernization of the quality of occupational training of future specialists due to the pedagogically balanced monitoring of the training of future specialists on the basis of lean-education involves: optimization of organizational and managerial structures, change in the technology of the implementation of educational functions, the introduction of informational technologies; change in the forms and methods of control, the focus on auxiliary, advanced control, shifting emphasis on the final result, record of the effectiveness of the educational process at a higher technical educational institution and the economical use of its capabilities, openness and democracy. The application of monitoring for the occupational training of future specialists at a higher technical educational institution is systematically determined, from the first point of view, by monitoring activities in the educational space, from the second point of view, by his personality and the educational route, and from the third point of view, by life conflicts and events in society. The environment for the implementation of monitoring technology in a higher technical educational institution is the technological process of "knowledge production" aimed at the economical use of its capabilities. The conventional image of monitoring process technology in a higher technical educational institution is its division into corresponding functional elements and designations of logical connections between them, which are specified as a monitoring scheme. Thus, the description of the monitoring process of occupational training is a staged sequence of monitoring activities with indication of the applied monitoring tools, which in turn serve as a kind of monitoring scheme for the occupational training of specialists, technological regulators, in which the completeness, efficiency,

achievability are differentiated, and the final result is individual acquisition of professional knowledge, skills and abilities by the participants educational process.

3.1. Specific Features of Monitoring of Occupational Training of Future Specialists in Context of Lean-Education

The occupational training of future specialists becomes systematic and purposeful, if it is studied not from the point of view of the "quality control model" parameter, but from the measurement of "quality assurance model". Taking into account the peculiarity of the process of occupational training at a higher technical educational institution and the transition from the "quality control model of occupational training" to the "quality assurance model of occupational training" through the system of monitoring of vocational training, the specific components of which are: the conceptual framework and the goals of educational activities stipulated by it; the content part – the content of the educational material and its structuring agreed with the didactic purpose; the procedural part – actually the technological process of introduction: organization of educational process, methods and forms of activities of future specialists, didactic system of teachers; the diagnostic apparatus – parameters, criteria, tools for researching the results of activities, procedures for monitoring the accomplishment of activities; models for technology implementation which are determined by the directions of permissible transformations of the first four regulatory components. The key source is filled with social transformation, science, and advanced pedagogical experience. Consequently, the monitoring of the occupational training of future specialists as a tool for quality control of occupational training is appropriate at all stages of obtaining professional knowledge, and the occupational training of future specialists in terms of continuing education on the basis of "economical knowledge production" is a system of continuous effectiveness monitoring of the educational process and, respectively, the prudent use of its capabilities at a higher technical educational institution as the dominant factor of occupational training of future engineers aimed at the constant detection and neutralization of educational losses for the development of professionalism and creativity by "drawing" (the term of lean-education) production of knowledge and its constant self-improvement. The theoretical and methodological dominants of the monitoring research as a quality control tool for the continuous technical education are based on the application and development of ideas of advanced occupational training due to historical, pedagogical, socio-political (modernization of the education system) and socio-economic (transition to market economy) preconditions. The presentation of the control process in terms of the structure of monitoring for occupational training as its quality tool enables to apply the main vectors of the competent approach for its design (Babak V., 2003), as "directions" of the methodology for scientific knowledge supported by modern teaching and mathematical methods of management based on object research as a system (monitoring), which consists of interconnected elements: higher technical educational institution and students, stages of monitoring, monitoring indicators (which provide for a complete idea of the state of various objects of the education system of qualitative and quantitative changes (occurring in it), monitoring diagnostic tools (a set of models, methods and technologies used to assess the quality of the educational process), evaluative activity (which is an "organization" for the conduct of monitoring procedures), etc. Application of integration scientific vision is confirmed by the available leading signs (Burkova E.V., 2000): the unity and integrity of monitoring qualities, structuring, the availability of functional characteristics, the hierarchy of relations between elements, the available system-forming parameter (goal). The structure of the monitoring for occupational training at the higher technical educational institution is made by the subjects of monitoring, monitoring stages, monitoring indicators, monitoring diagnostic tools and monitoring activities, which is the method to organize communication between the above-mentioned elements. The key objectives for the development of monitoring of occupational training (Valieiev M.M.,

1998) are as follows: to identify the trends in the development of the object under study; to create the informational conditions for forming a holistic view of the state of the system of continuous technical education, of qualitative and quantitative changes in it; to determine the dynamics of change of the basic parameters of the investigated object and the possibility to swiftly introduce corrections in the process of occupational training; to be capable of self-development, improvement and forecasting the results of the functioning of the research object. Therefore, the main tasks of the monitoring for occupational training acquire a new view, namely: to establish a rational list of measured parameters and criteria for evaluating the results, to form the initial information and analytical base for the functioning of the object being studied, to choose, develop and implement the scientifically grounded diagnostic tools (up-to-date pedagogical and mathematical models, methods and technologies for assessing the quality of the educational process), to research and correlate the gained results with the evaluation criteria for results in different qualimetric scales.

3.2. Pedagogical Conditions for Implementation of Experimental Monitoring Technology of Occupational Training of Future Specialists

Defining pedagogical conditions is an essential parameter for any scientific research, since it is a defined resource, the actualization of which in the context of a predetermined goal will contribute to the positive dynamics of the phenomenon under study. The pedagogical condition for formation of readiness as the result of occupational training of future specialists is considered to be the circumstances that affect the productivity of the researched process and are taken into account at all stages of occupational training of students at a higher technical educational institution. Based on the nature of the phenomenon under study, it has been established that such pedagogical conditions are components of the experimental monitoring technology for the training of future specialists at a higher technical educational institution on the basis of lean-education as follows:

- ensuring diversification of the professional readiness of a future specialist;
- providing pedagogical innovations in the process of forming the readiness of future professionals for the occupational activities;
- the use of interactive didactic means of advanced occupational training of the creative personality of a future specialist;
- organization of positive communication in the "teacher-scientist – future specialist" subsystem.

Thus, realization of pedagogical conditions during monitoring of occupational training of future specialists at a higher technical educational institution, which we will be further given in details, is aimed at forming professional readiness for engineering activities. This parameter of research was consistent with all components of the monitoring technology of the training of future specialists. So, each of the distinguished pedagogical conditions can be presented in details. Thus, the diversification of the system of higher technical education actualizes the expanded summative, hierarchical system of lean-education, which is connected with the formation of a new paradigm of educational function of the "educational, scientific and production" activity, providing the competitive advantages of a professional individual capable of an adequate response to world-wide demands of society; the diversification of the professional readiness of the future specialist is considered as a process and the result of his occupational training, which makes it possible to ascertain it as a process of changing the personal and professional growth of a future specialist in accordance with the needs of education, science and production. The specificity of diversification of the professional readiness of a future specialist naturally is to consider the transition of the system of occupational training of future specialists to a higher quality level of integrity (harmonious), which is conditioned by a number of educational,

organizational, economic, social and technological factors. With the development of innovative training based on lean-technologies, competition in the field of occupational training for future specialists is intensifying. In the process of creation, development and dissemination of innovations in higher technical education, an essentially new, modernized educational system (lean-culture) is formed as a global system of open, flexible, personalized "value" knowledge; lean-education of a person throughout his life. Taking into account the interests of all participants in the educational process, the transformation system of scientific knowledge into a value is the providing of pedagogical innovations. Accordingly, the providing of pedagogical innovations in the process of forming the readiness of future professionals for occupational activities is the system of integration of educational and formative interaction between subjects of the educational process under the conditions of a higher technical educational institution and internal personal and professional self-determination of the future specialist in the space of pedagogical reality and the transformation of occupational and pedagogical, scientific and production knowledge into a valuable educational product. Organization of providing of pedagogical innovations in accordance with the leading factors in the theory and methodology of occupational education is possible through pedagogical logistics as a branch of logistics which studies the management of pedagogical processes based on the principles of logistics and the principle of simple real systems that enables to synchronize the pedagogical system to economic systems at its approximate level of management (Yevtukh M.B., Voloshchuk I.S., 2008). This makes it possible to reduce the risk of inefficient use of funds for the development of higher technical education and thereby to increase the return on capital in this field. Actualization of lean-education at a higher technical educational institution is largely realized through interactive didactic means of advanced occupational training of the creative individuality of future specialists which contribute to the comprehensive manifestation of the double advance of higher technical education. In this process, it is fundamentally important to understand the purpose of occupational training in which the model of the future competitive specialist is given a grounding, and it is implemented on the basis of intensive lean-technologies. The basis of the organization of occupational training of future specialists is the system of developmental education (the educational environment in which a future specialist is not imposed by the normative construction of his professional and pedagogical activity, but is given the opportunity to determine the trajectory of individual creative development and, accordingly, the accumulation of scientific knowledge, practical skills and continuous formation of the mechanism of his self-organization and self-realization, development of cognitive abilities are assumed), the priority goal of which was determined in the development of professional skills of future specialists. The major significance in the organization of such activities is the implementation of individual coach-guiding, which involves identification of personal interests of future specialists, design of their professional path and construction of the monitoring technology for occupational training on the principles of lean-education, and directly, the processes of professional self-determination provide technology of coach-pedagogy which is the framework for the organization of positive communication. Professional pedagogical coaching is, in essence, a system of self-development and self-improvement of personal and professional qualities of a teacher during each moment of life through self-awareness and self-actualization leading to a productive interaction of a teacher with students based on trust and mutual respect. The central idea combining all these categories is the kaizen direction – constant self-development, the internal activity of a future specialist in his personal qualitative transformation; the process of constant self-improvement. Taking this, it can be concluded that the transformation of education into the mechanism of development of personality and society, the direction of higher education as a socio-cultural institution not to recreate the traditional norms of social life, but to develop a democratic, humane society, constant self-improvement is a pedagogical kaizen.

3.3. Research Results

The emphasis of the leading approaches of the research (personal oriented, personally active and systemic) contributed to deepening of the scientific understanding of the process of occupational training of future specialists, in the context of which a person is a value that provides professional growth by itself, and the activity is recorded at two levels: activities and behaviour; in turn, organization of occupational training of future specialists is a pedagogical system. By streamlining the axioms and research problematics, the main methodological principles are identified: didactic integration, individual educational path, lean-education, kaizen direction. The research of productive occupational training of future specialists within the coordinates of constructive pedagogical thought motivates to select the following key categories of research: diversification of the professional readiness of a future specialist; providing of pedagogical innovations in the process of forming the readiness of future specialists for professional activity; interactive didactic means of advanced occupational training of creative personality of a future specialist; positive communication in the "teacher-scientist – future specialist" subsystem. The research on the origins of the training of future specialists at a higher technical educational institution has made it possible to determine the most significant historical features of the educational process of a higher technical educational institution and to outline their prognostic features of influence on the development of modern higher technical education. They are as follows: updating and systematization of technical and pedagogical knowledge, purposeful accumulation of scientific experience; scientific and pedagogical on-the-job training (practically oriented occupational training within the triangle of "education – science – production"); occupational retraining (improvement of basic occupational training). It is essential that the understanding of the specifics of "step-by-step" occupational training of future specialists is actualized today. Therefore, the productivity of occupational training of modern specialists at a higher technical educational institution should be directly related to its development in the framework of educational benchmarking, that is, taking into account the world experience of forming the value flows of professional, profile, economic, and managerial knowledge which is an important tool of the system for quality provision and management as a new stage in the development of higher technical education.

The study of the labour market suggests that the culture of social dialogue of higher technical education with the economy requires the higher technical education institutions to provide special predictability, and the integration in the European dimension needs to increase the transparency of educational programs, to increase the comparison of qualitative parameters, to align the monitoring procedures. In this regard, the definition of competencies differentiated by the level of higher technical education for different areas (specialties) of training is a difficult process of operationalization of descriptors contained in the structure of qualifications of the European Higher Education Area. The study of the "content core" of the occupational training quality in the pedagogical theory and practice has given the opportunity to outline a new approach (different from the traditional logic of occupational training) such as the continuing education of a future specialist on the basis of prudence and providence using the capabilities of the educational process of a higher technical educational institution. Support and development of integration processes in the "education – science – production" system simultaneously provide both economic and social effects which radically predetermine the innovative structure of new educational products and types of educational services, their high competitiveness. Formation of innovative culture is a necessary component for the training of a new formation of specialists who are competitive in the development of new innovative products of both technical and educational character, in managing innovation projects, accumulating the experience of innovation activities and carrying out the transfer of the results of fundamental and applied research into the educational process, economics, science and production.

4. CONCLUSION

The priority direction for modernization of higher technical educational institutions is a competence-oriented approach aimed at achieving the goals of higher technical education: self-education, self-determination, self-actualization, socialization and prognostic development of professional individuality. The instrumental means to achieve these goals are fundamentally new educational structures: types, components, components of the educational process at a higher technical educational institution that has a personally significant, practically oriented, and active orientation, which, in turn, is built up within the triad of "education – science – production". The scientific analysis of the origin and diversification of pedagogical technologies enabled to deepen the scientific understanding of the experimental monitoring technology of occupational training of specialists at a higher technical educational institution, and made it possible to distinguish the criteria of technological effectiveness, such as: systematicity, conceptuality, up-to-dateness, scientific character, accuracy, integrability (integrity), consistency, optimality of costs, manageability, diagnostic goal-setting and design, reproducibility of the educational process and its outcome, qualitative and quantitative assessment of educational outcomes, planned performance. It is proved that monitoring of the occupational training of future specialists on the basis of lean-education is a purposeful, continuous, scientifically grounded, technological process of analysis, evaluation, acmeological support and forecasting of quantitative and qualitative changes in conditions, process and results of occupational training, their dynamics in order to improve the quality of occupational training of future specialists. The study of the origins of pedagogical logistics facilitated to the decrease of monitoring risks of non-productive use of funds for the development of higher technical education. By recreating the flow of logistics in a higher technical educational institution, the contribution was granted to providing the process of producing knowledge, eliminating the unnecessary knowledge and distributing the knowledge in the educational process. The purpose of this activity was to achieve the minimum expenses of pedagogical activity, to minimize the terms for creating a new "educational product", to guarantee the provision of knowledge of high quality within a minimum period of time. The following parts are the structural components of the experimental monitoring technology for the occupational training of future specialists on the basis of lean-education: conceptual, procedural, and technological. The efficiency vector of the monitoring technology of occupational training of future specialists was specified, and it became the "professional project" of a certain pedagogical system which was realized in practice with the help of integrative content of the occupational training of future specialists, forms, methods, means, procedures and conditions of training in the interaction between a teacher and a student. And the method of its organization was aimed at the optimal construction and implementation of the educational process and was based on personally oriented, personally active and systemic approaches to intensifying education, and it generalized the scientific knowledge and practical skills of future specialists in order to use them in educational and practical activities. It was established that the pre-condition for the formation of readiness as the result of occupational training of future specialists is the circumstances which affect the productivity of the process under study and which should be taken into account at all "stages" of training of future specialists at a higher technical educational institution. Proceeding from the nature of the phenomenon under study, it was determined that such pedagogical conditions are: providing of diversification of the professional readiness of a future specialist; providing of pedagogical innovations in the process of forming the readiness of future specialists for professional activities; the use of interactive didactic means of advanced occupational training of creative personality of a future specialist; organization of positive communication in the "teacher-scientist – future specialist" subsystem. Implementation of the pedagogical conditions within the monitoring technology of the occupational training of future specialists was aimed at forming the readiness of future

specialists for professional activity. The content load for the implementation of monitoring technology was the introduction (using the algorithm of "education – science – production") of its main components and methods for its evaluation. The updating of resources of a higher technical educational institution in the implementation of the experimental monitoring technology of occupational training of future specialists was in the reflection of the current situation in higher education and the mechanisms for its implementation, the provision of science-intensive content and educational technologies, the organic merger of scientific research with teaching at a technical higher educational institution, and the partner creativity of a teacher and a student.

LITERATURE:

1. Babak, V. (2003). Fundamental Training in Modern University: Traditions and Perspectives. *Higher Education of Ukraine*, No. 1, pp. 78-83.
2. Baidenko, V., Zatvord, J. (2001). *New Methods and Approaches to Organization of Educational Process (Goal-Oriented Approach)*: [report; "TASIS Delphi Project"]. Moscow.
3. Bisheno, J. (2007). *Education as a New Tool of Lean-Production for Creation of Fast and Flexible Flow*: [monograph]. Kaluga: Svet.
4. Burkova, L. (2000). Classification of Pedagogical Innovations as the Element of Management Mechanism of Innovation Process in Education. *Pedagogical Innovations: Ideas, Realities, Perspectives*, Collection of scientific papers. Kyiv, Logos, pp. 231-238.
5. Bykov, V. (2005). Theoretical and Methodological Principles of Modelling the Educational Environment of Modern Pedagogical Systems. *Information Technologies and Means of Education*, Collection of scientific papers. Kyiv, Atika, pp. 5-15.
6. Klarin, M. (1996). *Teaching Technology: Ideal and Reality*. - Riga: Experiment.
7. Larionova, M. (2006). Integration Processes in Education. European Experience. *Higher Education Today*. No. 2, pp. 46-52.
8. Luister, T., D. Tepping, D. (2008). *Lean-Production: From Something On Mind to Something in Kind*. Moscow: RIA "Standards and Quality".
9. Mihaylychev, E., Karpova, G., Leonova, E. (2002). *Pedagogical Diagnostics: History, Theory, Modern Age*. Rostov-On-Don: Institute for Education Management of Russian Academy of Education.
10. Ono, T. (2012). *Toyota Production System: Beyond Large-Scale Production*. Moscow: Menizdat.
11. Vader, M. (2007). *Instruments of Lean-Production: Mini-Guide On Introduction of Lean-Production Techniques*. Moscow: Alpina Biznes Buks.
12. Valeev, N. (1998). *Formation and Development of Additional Occupational Education of Students at Technical Higher Educational Institution*: [monograph]. Kazan: Publishing House of Kazan State University of Technology.
13. Voronin, M., Khokhlova, E. (2006). Quality is the Strategy of the XXI Century. *Higher Education in Russia*. No. 2, pp. 114-118.
14. Yermakova, S. (2007). Theoretical and Methodological Principles of Professional and Educational Space of Modern Specialist. *The Southern Ukrainian Law Journal*, No. 1, pp. 237-240.
15. Yermakova, S. (2009). *Psychology of Project Activity* [instructional manual]. Odessa: VMV Publishing House.
16. Yermakova, S., Badiul, O. (2010). *Intellectual Property with Basics of Innovative Management*. Odessa: VMV Publishing House.
17. Yevtukh, M., Voloshchuk, I. (2008). Providing the Quality of Higher Education is the Important Condition for Innovation Development of State and Society. *Pedagogics and Psychology*. No. 1, p. 12.

ENTREPRENURIAL BEHAVIOR CHANGING INFLUENCESD BY MIGRATION PROCESSES

Hanna Bei

*Vasyl' Stus Donetsk National University, Ukraine
h.larycheva@donnu.edu.ua*

Larysa Sarkisian

*Vasyl' Stus Donetsk National University, Ukraine
l.sarkisyan@donnu.edu.ua*

Ganna Sereda

*Vasyl' Stus Donetsk National University, Ukraine
g.sereda@donnu.edu.ua*

ABSTRACT

Development of an entrepreneurship in modern conditions is being influenced by set of factors, and one of them is migration processes. They can become an incentive for creation and development of the own business, to be a motivation of entrepreneurial behavior changing. The people forced to replace the habitation appear in the conditions promoting decision making for benefit of an entrepreneurship. It in turn is positively influencing the conditions of national economy even if migration processes are caused by negative tendencies. This article considers how forced migration stimulates an entrepreneurship and affects an entrepreneurial behavior in aspect of the international experience and realities of the Ukrainian economy. The increase in entrepreneurial activity caused by migration processes is researched, the level of their importance in case of decision making to begin own business in comparison with seven main motives of business activity is analysed. The main spheres of business which migrants are inclined to choose and degree of their economic success are determined. The received results have both the theoretical and practical value as allowed to formulate a tendency of influence of migration on business activity strengthening and to prove change of entrepreneurial behavior. It is revealed that the main motives stimulating an entrepreneurship in the conditions of migration are, first of all, desire to provide itself and the family with stable income, implementation of own business idea, lifework, aspiration to financial independence. At the same time, entrepreneurs are more inclined to show ethical qualities in business (socially responsible business, high-quality and ecologically safe product, customer relations) and are less inclined to the termination of business activity in the conditions of crisis.

Keywords: *Enterprenuership, Enterprenerial motivation, Migration processes*

1. INTRODUCTION

It is difficult to overestimate influence of an entrepreneurship on the modern economy because creation of new business and increasing of existed ones demonstrate economic freedom and positive economic trends. There are a lot of research papers devoted to the problem of the newly created enterprises activity in dynamically developing economies (Lazear, E.P., 2005, pp. 650-651), including the economic theory (Drucker, 1993, pp. 10-15). At the same time, considerable attention of researchers attended to general entrepreneurial behavior, its economic feasibility and factors that intensively influence it (A.Perenyi, R.Zolin, A.Maritz, 2018). Researches highlights the following factors impacted the behavior mentioned below: the internal psychological motives causing desire to begin own business, and external which can induce to business activity and strengthen influence of internal (De Jong, Jeroen P. J., Parker and others, 2015).

Usually, the following factors are marked as entrepreneurial qualities: aspiration to independence, high tendency to risk, commitment, innovative activities (Barba-Sanchez, Atienza-Sahuquillo, 2012, p.133). On the other hand, intensive development of behavioral theories recently more often changes the sphere of researches attention from rational to a motivational component of entrepreneurial behavior in search of the answer to a question what of behavioral factors exert the greatest impact on decision making about opening of own business (Douglas, E.J. and Shepherd, D.A., 1997). As for external factors it should be mentioned that the migration processes that considerable geopolitical transformations in the world, in our opinion, is one of the most important. People is forced to change the place of habitat because of military activities in regions, standards of living decrease processes, losing of job places by reason of technologies obsolescence, closing of the large state enterprises, etc (Marc Gruber, Ian C. MacMillan, 2017). Also people have opportunities to begin their own business and to show entrepreneurial capabilities. Some researchers mention that the entrepreneurship wave caused by migration processes can lead to deterioration in an economic situation in the region as most often the entrepreneurs, forced to begin the business in connection with migration, have lower level of required skills and knowledge (Naudé, 2011). The inefficiency of the made decisions leads to fast closing of business and disappointment in the entrepreneurial capabilities that is displayed in decreasing of bank loans return, increasing of unemployment, etc. (Naudé, 2015). Some Ukrainian researches also investigate the problem of the interconnection between migration and entrepreneurship. For example, M. Dolishny and S. Zlupko (1997) mention that developed labor market and the adjusted processes of a labor is the main condition of maintaining an effective entrepreneurship availability. The labor migration is based on need of ensuring a quantitative and high-quality labor power requirement of different regions of the world and countries and also aspiration to implementation of internal needs of the personality (Kashuba O.M., 2013, p. 435). Thus, in the course of forced migration there is an element of a labor migration, because movement of the population happens most often to regions with high rates of the labor market and the higher are these indicators, the more chances of success have the entrepreneur. The aim of the present article analyzes migration processes influence on the entrepreneurial behavior changing process as well as identification of the dependence availability dependence between the level of forced migration and increasing of the tendency towards to be a private business undertaking.

2. ENTREPRENEURIAL BEHAVIOR AND MIGRATION

2.1. The concept of entrepreneurial behavior

It is difficult to carry an entrepreneurship to a regular labor activity as it in essence characterizes creative and vigorous activity of businessmen, contains special useful philosophy of system of managing (Garkusha V. V, 2008). The entrepreneurship is a driving force of economy as allows to create new products, to open new types of activity, to stimulate the economic growth and development of society. The main motive of business activity often are called commercial purposes, such as profit earning and high income level (Schumpeter, 1982). However later researches confirmed that along with it, the aspiration to success, expansion of spheres of influence, creation of opportunities for self-realization, development of creative capabilities becomes a motive to an entrepreneurship. The tendency to an entrepreneurship is explained by modern researchers from the rational and behavioral points of view. Rational means manifestation of tendency to an entrepreneurship, desire to undertake an entrepreneurial risk in optimum conditions, in the presence of positive external factors and internal motives, desire to self-actualize in the chosen sphere, to get profit (Busenitz and Lau, 1995). Representatives of behavioral theories of entrepreneurial behavior change are concentrated on studying of the internal motives influencing the entrepreneur (Barba-Sanchez, Atienza-Sahuquillo, 2012, p.133).

According to the dynamic theory Atkinson and Birch (1978), human life represents the flow of behavioral reactions characterizing change of one type of activity with another. If it is necessary to make a choice from a set of options, the motive will be stronger, and the more positive results it will bring, the more is than chances at adoption of this decision. Motives can be internal and external, depend on political, economic factors, a labour market situation, availability of favorable conditions for conducting business activity and also to be based on internal needs of the person, his opportunities, experience, world outlook. Most of authors agrees on availability of three main motives: goal achievement, competition, independence (Herron and Robinson, 1993) and also such factors as desire to gain high income and the need of recognition for society (Karamushka L.M., 2005). Motives serve as motivation to action and in common conditions their importance is distributed in such sequence on importance degree. The person, inclined to an entrepreneurship, is more often than others showing commitment and strong desire to implement everything exactly as it is conceived, makes plans for the future, derives pleasure from the personal liability for result. In that case future entrepreneurs approach process of creation of own business consistently, gradually acquiring skills, knowledge and skills of business, are more often more ready morally to consequences of risk decisions and are capable to continue competitive struggle even in the conditions of protracted crisis. More over, the motivation to business activity can be considered from two points of view: at a receipt stage to business activity and at a stage of its stabilization. In general decision making about creation of own business is influenced by such external factors as social and economic (social and political stability of society, efficiency of a legal mechanism), organizational (the sphere of business activity), social and demographic (age, sex) factors, and at a decision making stage about business continuation - degree of its success. Long time the main personal motives for conducting business activity in Ukraine are desire to provide high level of living for themselves and the family (42,2%), aspiration to independence (37,8%) and self-realization (35,6%) (Rudkovska, 2016) and a situation significantly did not exchange, despite of socio-political and economic changes.

2.2. Migration influence

Influence of migration processes on an entrepreneurship can be considered from the point of view of a labor migration and forced migration, connected with contingencies. Migration movement can act as the indicator of reaction of the population to change in economic, political, social life of society, and its amount, the directions and scales testify to stability or instability of social development (Kashuba, 2013). Entrepreneurial migration at the same time acts as a part of a labor migration (Harris and Todaro, 1970), implying conscious movement of a labor power in search of favorable conditions for self-employment and business. At the same time, the entrepreneur risks success of the activities, an opportunity to receive or not the profit, in comparison with regular labor migrants who risk is to find not a workplace with the desirable pay level of work (Marthen L. Ndoen1, 2000). In most cases such type of an entrepreneurship based on natural processes of a labor migration is considered more conscious, allowing entrepreneurs to show own tendencies and management skills in the region with more favorable external conditions. In case of forced migration the entrepreneurial activity can be shown for lack of tendency to an entrepreneurship and necessary skills that is caused by impossibility to find a job in the new region and the need for financial provision of yourself and the family. At the same time the need for receipt of high income advances all other motives of an entrepreneurship and success of conducting own business, its continuations considerably depends on the level of this income. The migrants who remained without means of support, the real estate or other property, in this case become more inclined to an entrepreneurial risk as they "have nothing to lose anymore" (Neville et al., 2014). They are more persistent and show higher commitment, creativity in the problem resolution and competitiveness as they were pushed out

by circumstances from the habitual labor market to the sphere of self-employment (Brixy et al., 2013). Migrants are seen to have access to supplementary sources of support, training and financing, as often migrants increase their educational level or gain new skills, save more money and extend their social network while living abroad (Naudé, 2015). Growth of entrepreneurial activity can potentially lead to serious rise of economic development through increase in level of investments and demand for financial instruments, development of the local labor market, expansion of the range of products or services in the region, which can differ considerably from habitual and attract keen interest of consumers. The international experience demonstrates that the countries and certain regions seek to increase appeal of the territories to migrants from the different countries for increase in business activity and improvement of economic and social indicators. For example, for involvement of immigrants to Detroit in the United States about business potential has created the program of "The center of development of the neighbourhood" which assumes providing technical assistance for businessmen, granting the small credits for creation and development of business and holding trainings in the main districts of the city. According to this organization, each invested dollar in business activity allows to receive 28 dollars. In Australia in the region South Australia the local government has created the program for involvement of highly educated professionals and business of migrants to the state, thus creating additional drivers of development. Similar strategy was created by the government of New Zealand. Agrees with researches, one of six new created enterprises in the United States are the property of immigrants that speaks about increase in influence of immigrants businessmen on creation of value added and increase in enterprise activity for development of territories.

3. FORCED MIGRATION INDICATORS

The number of migrants according to the UN grows in the world, so in 2000 the total number of migrants constituted 174 million, in 2013 already 232 million, and in 2015 - 244 million people. Partially it is promoted by development of transport connection and means of communication, openness of borders and the phenomenon of globalization, but driving forces of migration remain invariable – search of safety and means of livelihood. Respectively global migration flows move to the peace countries with developed economy (G20) where more than two thirds of all world migrants live. Events since 2014 promoted in Ukraine to revival of migration processes. The economic crisis, military operations in the Crimea and in the east of Ukraine led to increasing in level of migration as within the country, and out of its borders. Poland and Russia remain the most popular directions of migration of Ukrainians, at the same time the starting from 2014 goes reorientation of labor migrants to Poland and other EU countries (Figure 1).

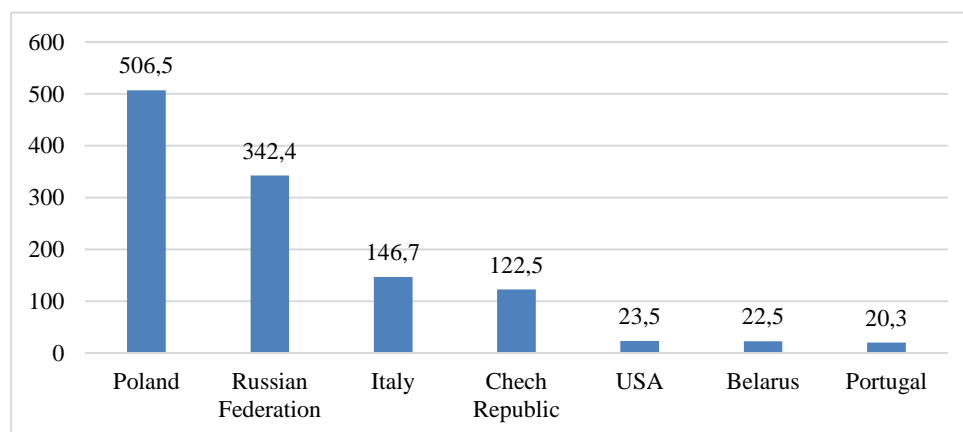

Figure 1: General flows of labour migration in Ukraine (Government Statistic Department of Ukraine, 2017)

Among external migrants the number of those who could open own business is small, generally labor migrants from Ukraine find a job in the sphere of a construction, housekeeping and service trade (Migration in Ukraine: facts and figures, 2016). As for an internal labor migration, the number of such migrants increased due to growth of internally displaced persons. For today their total number reached 1,502 million people. The largest number of IDPs is registered in Donetsk, Luhansk, Kharkiv, Dnipropetrovsk and Kiev regions (Figure 2).

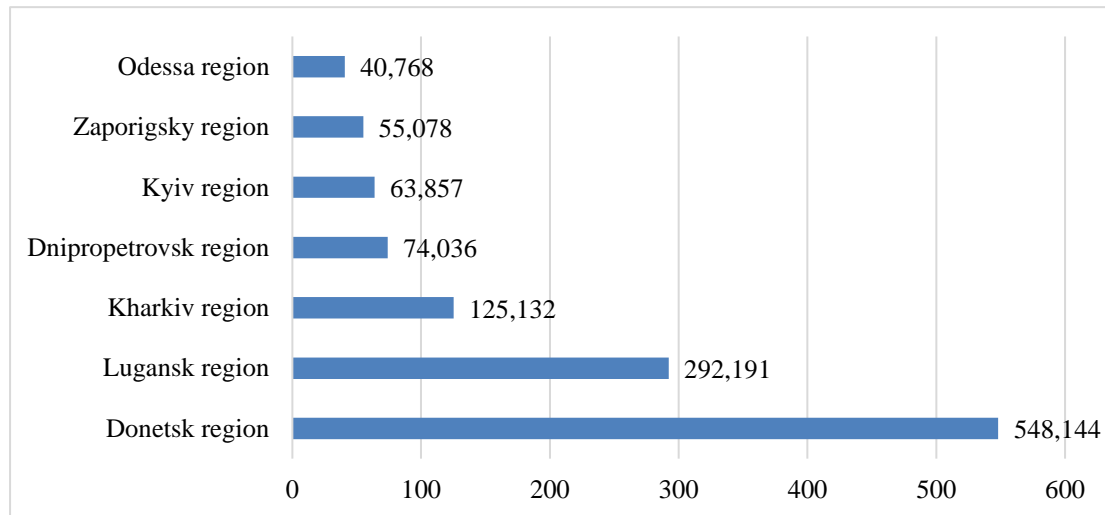

Figure 2: Main directions of IDPs migration in Ukraine (Slovo i Dilo analytics, 2018)

About 54% of the income of IDPs are forced to spend for food and ensuring basic requirements that brings closer them to poverty line, causing need of search of sources of higher income. Many IDPs lost the place of full-time employment and experience difficulties with search of new places of employment that is caused by features of the labor market of Ukraine and professional specialization not peculiar to other regions of the country. Thus, IDPs of Ukraine appear in the conditions of forced migration today that can serve as an incentive by the beginning of business activity.

4. RESULTS OF EMPIRICAL RESEARCH

4.1. Methodology and information

According to research priorities, the attention was focused on IDPs of Ukraine which opened own business after changing of the place of habitat and also on how their behavior due to the need to leave the habitual residence changed and what were the main motives which induced them to become entrepreneurs, the level of knowledge and abilities necessary for the entrepreneur, tendency to risk. This empirical study is based on data collected using the survey methods reported in this section. The methodology we used to conduct this study is reported in the following three sections: data collection, measurement and data analysis.

4.2. Data collection

For accomplishment of a research the questionnaire, the directions on studying of the basic reasons and motives, which induced IDPs to opening of own business, was created. We collected the data for this study via questionnaire surveys. A survey was forwarded by mail to all contacts and in form of phone-interview for a mostly successful of them. Overall, 95 questionnaires received from founders, but only 91 were correctly completed, which indicated a confidence level of 95,7%. The data suggest that Ukrainian entrepreneurs are mainly men (87%) and only 13% of the respondents were women. Average age is 36 years but there were responders, who started their business at 24 years of age and at 45 or later too.

Before responders started their own business, they mainly worked for others and accumulated nearly 5-7 years of experience, some of them around 15-20 years, usually in the different sector. Quizzed entrepreneurs had opened their business in different spheres. Most of them started in sales (51%), but there also were services (23%), restaurant or food business (11%), domestic production (9%) and other (6%). There are representatives of the most successful businesses in all of them, and there are some new trademarks with unique products known all over the Ukraine (clothes and accessories manufactory, food, drinks etc.). Regarding the characteristics of the created companies, most respondents chose limited liability companies, though they retained most decision power and reserved rights to more than 50% of the capital. These companies also mainly represented micro businesses, because their average number of workers was only 5,078. Their education level is mostly high (bachelor or master's degree), but there were some of them with average education and those, who did not finish their compulsory education.

4.3. Data analysis

For the analysis of the received results all data were grouped and ranged on importance degree. Answers to questions disclose the main motives which induced entrepreneurs to begin own business, level of knowledge and skills in the sphere of an entrepreneurship prior to work and eventually, degree of tendency to risk, availability or lack of advantage factors in the region, success of business, level of its innovation and also the main problems and obstacles which respondents in the course of business activity faced. In total 10 motives called by entrepreneurs such that induced them to begin own business were marked out. As expected, on the first place on degree of the importance there was a need to provide itself and the family. Further there is desire to gain higher income, to be independent and also to start own business, to have interesting work, to realize the idea or an old dream. The important place among motives was taken also by aspiration to higher social status, personal and professional growth. The family tradition and following to someone's example of success finish the list (tab. 1).

Table 1: Scale of Entrepreneurs Motivation score

Motives	Mean (5 – extremely important, 4 – very important, 3 – mildly important, 2 – not very important, 1- unimportant)
Need to provide itself and the family	4,28
Desire to gain higher income	4,15
To be independent	4,00
To start own business	3,85
To have interesting work (lifework)	3,67
To realize the idea or an old dream	3,31
Aspiration to get higher social status	3,12
Personal and professional growth	2,97
Family tradition	2,20
Following to someone's example of success	1,60

As for that, how prepared for business activity respondents were before they started their work and how they estimate themselves now, the most part of answers confirms that before business start the level of knowledge was average or minimum (47%), about a third of respondents answered that they had brief experience in the sphere of an entrepreneurship (29%), the others noted that they had a necessary set of knowledge and abilities (24%) (tab. 2). In the course of work on creation and development of own business entrepreneurs aimed at increase in the professional level, being engaged in self-education or attending additional trainings and classes.

Table 2: Entrepreneurial Skills and Knowledge level analysis

Mean	Assessment before starting business	Assessment after developing business
Extremely high level	0,10	0,11
High level	0,14	0,20
Mild level	0,29	0,37
Satisfactory level	0,36	0,26
Unsatisfactory level	0,11	0,06

In addition, respondents note that with business development they became less inclined to risk, unlike times when they only began own business. About a half of respondents are ready to begin new business, at the same time consider the enterprise successful approximately the same number of business owners. Concerning a situation in which entrepreneurs began own business many noted external conditions as adverse, in particular a problem of search of financial provision, high cost of lease of rooms, difficulties with paperwork. On the other hand, the commitment, participation in projects made for the help of IDPs and support of an entrepreneurship by the EU and local financing, demand of the created product or service in the market, influenced business development positively. Moreover, the research showed that the entrepreneurs forced to replace the residence in Ukraine were more inclined to conducting ethical and socially responsible business (67%). So interviewed entrepreneurs emphasize that bear responsibility for quality and ecological compatibility of the made product (58%) and the subordinates (35%), value the personnel and are ready to make efforts for increase in the engagement of their work (30%). Also important place is taken by relations with consumers – respondents pay attention to preserving and deduction of new clients, the unusual and efficient systems of increase in loyalty, active use of electronic means of communications and social networks.

5. CONCLUSION

The conducted research shows that the level of entrepreneurial activity which depends on external and internal factors plays an important role in the modern world. The increasing level of forced migration (because of military conflicts, sharp deterioration in economic situation in regions) is one of the most important negative factor impacted an entrepreneurship. The result of this factor impact is the process when people start some business activity because of needs to make personal and family provision, financial independence and high profit, implementation of the new creative idea. As a result, people earlier not inclined to entrepreneurial activity achieve success in business even if they don't have some entrepreneurial background. According to the research on Ukrainian IDPs the following conclusion should be stressed: the interviewed forced migrants were pushed out from the habitual labor market and chose an entrepreneurship as self-employment. The most of them appeared in adverse conditions of maintaining an entrepreneurship (some financial problems; problems with the legal paperwork. However, the high commitment, correctly chosen business strategy, increase in social responsibility and ethics of business provide them opportunity to be succeed in chosen spheres.

LITERATURE:

1. Aron Perenyi, Roxanne Zolin, Alex Maritz, (2018). The perceptions of Australian senior entrepreneurs on the drivers of their entrepreneurial activity, *International Journal of Entrepreneurial Behavior & Research*. Vol. 24. Issue: 1. pp.81-103.
2. Atkinson J.W. and Birch, D. (1978) *Introduction to motivation*. New York: Van Nostrand.
3. Brixey U., R. Sternberg, and Vorderwülbecke A. (2013). Business start-ups by migrants. *IAB Brief Report 25. Nürnberg: Institute for Employment Research*.
4. Busenitz L.W. and Lau, Ch. (1995). A cross-cultural cognitive model of new venture

5. *Business Migrants of New Zealand (2017)*. Retrieved 19.03.2018 from: <http://migration.sa.gov.au/upload/publications/Business-Migrants/Business-e-pack.pdf>
6. creation. *Entrepreneurship Theory & Practice*. Vol. 20. pp. 25-40.
7. De Jong, Jeroen P. J., Parker, Sharon K., Wennekers, Sander and Wu, Chia-Huei (2015). Entrepreneurial behavior in organizations: does job design matter? *Entrepreneurship Theory and Practice*. 39 (4). pp. 981-995.
8. Dolishnij M.I., Zlupko S.M., Zlupko T.S., Tokarskyj T.B. Labour potential, employment and labour market (1997). *Lviv: Lviv IBC publishing*. p. 151.
9. Douglas E.J. and Shepherd D.A. (1997). Why entrepreneurs create businesses: a utility maximizing response. *Frontiers of Entrepreneurship Research*. Vol. 17. pp.185-186.
10. Drucker P. (1993). *Managing in Turbulent Times*. New York: Harper & Row.
11. *Dynamics of Ukrainian migration: where main IDPs lives (2018)*. Retrieved 11.05.2018 from: <https://www.slovoidilo.ua/2018/05/11/infografika/suspilstvo/dynamika-mihracziyi-ukrayini-zhyve-najbilshe-pereselenciv>
12. Entrepreneurial Migration and Regional Opportunities in Developing Countries, Marthen L. Ndoen¹, Cees Gorter, Peter Nijkamp, Piet Rietveld (2000), *Department of Spatial Economics, Vrije University Amsterdam-The Netherlands*, 26 p.
13. Harkusha V. V. Entrepreneurship and social responsibility (2008). *Visnyk KDPU im. Myxajla Ostrohradskoho*. Vol. 5. pp. 188-190.
14. Harris, J. and Todaro, M. (1970). Migration, unemployment and development: A two-sector analysis. *American Economic Review*. Vol. 60(1). pp. 126-142.
15. Herron L. and Robinson, R.B. (1993). A structural model of the effects of entrepreneurial characteristics on venture performance. *Journal of Business Venturing*. Vol. 8. pp. 281-294.
16. *Immigrants and internationals: business owners (2017)*. Retrieved 09.04.2018 from: <http://www.globaldetroit.com/immigrants-and-internationals/business-owners/>
17. Karamushka L. M. *Technologies of professional psychologists work: Book (2005)*. 366 p.
18. Kashuba O. M. Economical consequences of labour migration for entrepreneurship of Ukraine (2013). *Soc.-ek.problemny suchas.periodu Ukrayiny*. Vol. 3(101). pp. 434-443.
19. Lazear E.P. (2005). Entrepreneurship. *Journal of Labor Economics*, 23, 649–680.
20. Marc Gruber, Ian C. MacMillan. (2017). Entrepreneurial Behavior: A Reconceptualization and Extension Based on Identity Theory. *Strategic Entrepreneurship Journal*. Vol. 11. Issue 3. pp. 271-286.
21. Migration in Ukraine: facts and figures (2016). *International migration organization, Ukraine representative*. Retrieved 21.04.2018 from: http://iom.org.ua/sites/default/files/ff_ukr_21_10_press.pdf
22. Naudé W. (2011). Entrepreneurship is not a binding constraint on growth and development in the poorest countries. *World Development*. Vol. 39 (1). pp. 33-44.
23. Naudé W., Siegel M., Marchand K. Migration, Entrepreneurship and Development: A Critical Review (2015). *IZA Discussion Paper No. 9284*. Retrieved 12.04.2018 from <http://ftp.iza.org/dp9284.pdf>
24. Neville F., Orse, B., Riding, A., and Jung, O. (2014). Do young firms owned by recent immigrants outperform other young firms? *Journal of Business Venturing*. Vol. 29 (1). pp. 55-71.
25. Rudkovska V. Entrepreneurship as special type of economical thoughts (2011). *Visnyk Kyyivskoho nacionalnoho un-tu im. T. Shevchenka*. pp. 89-91.
26. Shumpeter I. (1982) *The theory of economical development: research of entrepreneurial profit, capital, loan, interest rate and conjuncture cycle*. M.: Progress. 456 p.
27. V. Barba-Sanchez, C. Atienza-Sahuquillo (2012). Entrepreneurial behavior: Impact of motivation factors on decision to create a new venture. *Investigaciones Europeas de Dirección y Economía de la Empresa*. Vol. 18. pp. 132-138.

CRISIS MANAGEMENT AND HOW TO EMPOWER IT WITH CROWDSOURCING

Goran Pavelin

*University of Zadar, Department of Tourism and Communication Studies, Zadar, Croatia
gpavelin@unizd.hr*

Djani Bunja

*University of Zadar, Department of Tourism and Communication Studies, Zadar, Croatia
gianni@unizd.hr*

Franjo Mlinac

Sutivan Public Library, Sutivan, Croatia

ABSTRACT

The paper presents the topic which has been treated by many researchers and which speaks in favour of finding technological solutions for the processing and verification of the relevance of the abundant data set. The goal is to obtain relevant information which can be used not only for inputs to agencies in charge of resolving the crisis but also for the creation of “collective intelligence” which can enable, faster than any media used by crisis management, the affected to get the key and verified information and help them in making right decisions. Some of the platforms which are being developed for this purpose are explained in this paper. Also, the paper assesses their usefulness and mentions other positive examples of the social media use by government institutions, a local government and world public services.

Keywords: *crisis management, crowdsourcing, government, information processing, public*

1. INTRODUCTION

It is questionable how much today's crisis management practices by governments and government agencies take into account social networking which is especially Twitter and Instagram, greatly used by the population. In crisis situations these social media show high activity and produce an enormous amount of data during the outbreak and duration of the crisis events. Secured access to information can save a lot of resources to government agencies which collect data from crisis locations. It can help them make the right decisions on implementation of measures which ensure security of human lives, reduce property damage and faster the mastering of the crisis with the aim to extinguish it. One of the biggest problems is the fact that among millions of produced data a large part is not relevant for the purposes of crisis management, and there can also occur deliberate data manipulation which can produce high security risks. Traditionally, crisis management belongs to domain of a state and local government and public services and is one of their most important tasks (Questia, 2017). At all levels governments are involved in the management of crises and disasters through public services they establish. Nowadays governments are faced with an increased number of crisis situations which often contain new types of threats (OECD, 2013). The complexity of modern crises requires the involvement of many participants apart from emergency services and this requires effective coordination with the aim of a successful outcome (OECD, 2013). The need for coordination raises a significant challenge to public governance. It is the ability to coordinate crisis management the key element of good governance as it tests government capacity to ensure an adequate response at the right time in order to protect the population and economy by mitigating the impact of crisis events (OECD, 2013). In the moments of the crisis breakout the public expects from its government to explain what is happening and why it is happening and to be able to minimize the impact of the crisis (Questia, 2017).

This task is even more important in the era of modern technology when 24-hour television programs and the Internet monitor and publish every move of the government (Questia, 2017). Under such conditions the governments pay great attention to five critical functions of management: decision-making, understanding of events, eliciting the meaning out of the event, containing the crisis and learning about the crisis after settling the crisis situation (Questia, 2017). In order to understand events the government relies on informing mechanisms through services and institutions which operate in the case of emergencies. These services send reports from the field. On the basis of these reports the government is trying to comprehend what is really happening in order to initiate crisis management mechanisms at the global and local level. Many theorists of crisis management and many scientists who study the effects of social networks warn about huge amounts of information produced by the crisis-affected population and point out their possible use in crisis management. Through applications mobile technologies have begun to play a role in preventing the crisis, its management and the reaction to the crisis, and they also provide people with life-saving information in moments of danger (Retrieve, 2017). When faced with an unexpected crisis, people quickly try to gather as much information from the sources that are currently available (Castillo, 2016). During the crisis all involved in it such as the public, the media, the government, emergency services, humanitarian organizations and others quickly try to become aware of the situation. This process involves perception, conscious understanding and ability to make assumptions about future events (Vieweg, 2012). The achievement of situation awareness is considered to be an aspect of collective intelligence which involves an interaction of many participants with a combination of different sources of information (Palen et al. 2010). When faced with the crisis, people rely on systems and networks which are the most relevant to them (Potts, 2014). Their main benefit is the capacity scale and the speed of information flow (Retrieve, 2017). Social networks can help in the process of understanding the situation, but it is very difficult to handle an enormous amount of complex information in real time so that the relevant information could be immediately utilized (Castillo, 2016).

2. THE CONCEPTUAL DEFINITION OF CROWDSOURCING

According to the Merriam-Webster dictionary the term crowdsourcing means: “the practice of obtaining needed services, ideas, or content by soliciting contributions from a large group of people and especially from the online community rather than from traditional employees or suppliers“. Today crowdsourcing is best known as a business idea that gives companies insight into customer expectations and satisfaction with a certain product (Alsever, 2007). These practices are made possible because of the growth of the user-generated media such as blogs, wikis, You Tube and, of course, social networks like Facebook, Instagram and Twitter. The authors (Imran, Castillo, Diaz & Vieweg, 2015) emphasize Twitter as an extensively used communication channel, especially in the large-scale convergent events such as natural disasters: earthquakes, floods and typhoons. In recent years scientific studies have indicated great importance of messages distributed to social networks because they contain important actionable and tactical information (Imran, Castillo, Diaz & Vieweg, 2015); (Imran, Elbassuoni, Castillo, Diaz & Meier, 2013); (Cameron, Power, Robinson & Yin, 2012).

3. ISSUES OF INFORMATION PROCESSING IN CRISIS

The biggest problem is the efficient processing of this enormous amount of information. This can be accomplished by means of NLP (Natural Language Processing) methods such as information extraction, classification and named-entity recognition (Bontcheva, Derczynski, Funk, Greenwood, Maynard & Aswani, 2013) but a big part of the messages is very short and contains slangs, typographical errors, incorrect grammar, abbreviations and the like (Han, Cook & Baldwin, 2013).

These disturbances degrade the work of NLPs during the processing (Foster et al. 2011). In their work the authors (Imran, Mitra & Castillo, 2016) have presented Twitter Corpora containing more than 52 million messages produced during 19 different crisis situations in the world from 2013 to 2015. Twitter data were collected via the AIDR (Artificial Intelligence for Disaster Response) platform (Imran, Castillo, Diaz & Vieweg, 2015) which in crisis situations allows the collecting of the messages with a specific keyword or from a specific geographical area using Twitter's streaming API (Application Program Interface). The presented data show that the largest number of tweets was produced during the Palestinian conflict, over 27 million tweets, then during an outbreak of Ebola virus and great floods in India, over 5 million tweets, and over 4 million tweets during the earthquake in Nepal and the disappearance of Malaysia plane (Malaysia Airlines flight MH370); (Imran, Mitra & Casillo, 2016). In the test data processing the authors combined human evaluation and machine learning. Volunteers or paid staff annotated the received messages in an annotation scheme which set nine different categories of classifying messages: injured or dead people, missing, trapped or found people, displaced people or evacuations, infrastructure or utilities damage, donation needs or offers or volunteering services, caution and advice, sympathy and emotional support, other useful information, not related or irrelevant. The data processing made by volunteers facilitates machine learning which has been conducted using three well-known learning algorithms: Naive Bayes, Support Vector Machines and Random Forest. After the processing performed by algorithms on the complete sample of 52 million messages the word embedding has been implemented using word2vec. The volunteers have been engaged through Stand by Task Force (<http://www.standbytaskforce.org/>) and messages have been annotated by the Micro Mappers platform (micromappers.org). Errors that occur in writing of the messages (Out of vocabulary - OOV words) are divided into: Typos/misspellings / Single-word abbreviation/slangs / Multi-word abbreviation/slangs / Phonetics substitutions / Words without spaces. It has been noticed that the largest number of errors belongs to misspelled words which can be corrected using one edit-distance change, while other OOV words have to be distributed to the volunteers to be corrected before their release in the system (Imran, Mitra & Casillo, 2016).

4. CONSTRUCTION OF CROWDSOURCING SYSTEM

The architecture of the hybrid crowdsourcing / machine learning system on the example of AIDR (Artificial Intelligence for Disaster Response) is explained in the work by Ofli et al. (2016). According to the authors the AIDR platform efficiently processes the abundant network streams maintaining high accuracy of classification at the rate of 500 units per second, which is a double capacity with regard to the observed peak rates during the actual crisis. It is based on the crowdsourced stream processing approach, which in the stream processing architecture combines human and machine intelligence providing high quality and low latency (Ofli et al. 2016). It relies on a group of volunteers for labelling and on machines for automatic classification. As a crowdsourcing model, the Micro Mappers (<http://clickers.micromapper.org>) module has also been used. It is powered by the PyBossa (<http://pybossa.com>) crowdsourcing platform (Ofli et al. 2016). The authors explain the architecture of the AIDR module: The collector module collects messages from a lot of data sources, in this case from Twitter, using specified keywords, hashtags or geographical regions. Then the Tagger module, using supervised learning for classification of messages, selects single elements and sends them to be labelled by crowdsourcing workers or digital volunteers. The labels coming from crowdsourcing are sent to the Learner module. It refreshes or initially creates a classification model that is then used by the Tagger which processes the data received from the Collector using the best available model (Ofli et al. 2016). Reliability of classification is determined by the efficiency of used machine learning algorithms and the quantity and quality of labels which have been used for machine learning (Ofli et al. 2016).

The cost of using this system is determined by the time which volunteers have invested in labelling. According to (Ofli et al. 2016) in order to reduce the amount of data which has to be processed by digital volunteers, duplicate and near-duplicate messages are removed in a way that they are handled as a single task, while the active learning is used to selectively choose items that lead to classification progress.

5. IMPLEMENTATION OF CROWDSOURCING IN CRISIS MANAGEMENT

Reflections on the efficiency of social networks are largely driven by the media covered experiment DARPA (Defence Advanced Research Projects Agency) Network (Red Balloon) Challenge (Popoola et al. 2013). In 2009 DARPA announced that it set ten numbered weather balloons on unknown locations within the United States and offered the prize of \$ 40,000 to the first person or team that signals the exact location of all the balloons (DARPA, 2010). The aim of the experiment was to identify different mobilization strategies and demonstrate how rapidly a demanding geolocation problem can be solved through crowdsourcing. The winning team of MIT (Massachusetts Institute of Technology) has managed to give information about all balloon locations in only 8 hours and 52 minutes (DARPA, 2010). The analysis has shown that the MIT team used social networks, crowdsourcing and recursive incentive mechanism (DARPA, 2010). Along the way they have successfully eliminated false information that was planted by rival teams. While recruiting people through social networks, the MIT team has promised to share a cash prize, if they win it, with the people who helped them in the search and in the following way: Each person who first spots the single balloon and tells its coordinates gets \$ 2,000, people who recruit the finders of balloons get \$ 1,000, anyone who involved callers of the finders gets \$ 500, the callers get \$ 250 and so on (Popoola et al. 2013). This is called the application of the recursive incentive mechanism. On the basis of the knowledge that has been acquired by studying these methods, the Popoolin team (Popoola et al. 2013) has designed a platform called Verily (<http://www.veri.ly>). It allows mobilization of people in a geographic area that is close to the outbreak of the crisis. These people should be qualified to evaluate the evidence for the purpose of checking the accuracy of different statements published on social networks. The platform should enable humanitarian and government organizations to quickly evaluate which information correspond to their standards of trustworthiness based on the presented evidence. This would enable faster and more reliable inclusion of critical information on the crisis in the coordination and management of the crisis. The initiation of the platform occurs by publishing the verification requirement which has to be structured as a yes-no question related to the event (Popoola et al. 2013). The authors give an example of the question such as: „Has the Brooklyn Bridge been damaged by Hurricane Sandy?“ The publication of this requirement initiates the collection of evidence that can show whether the supposed event occurred or not. The procedure is carried out through evaluation of collected evidence that is included in the judgement. Verily also uses the incentive platform, not monetary one. It uses it through virtual points. It has been shown that the offering of monetary compensation in cases of reactions to the crisis may be considered repulsive and offensive by volunteers. Points are given only for productive participation; this includes true confirmation or denial of certain affirmation. It has been proved that people like to collect points for their work because it provides them recognition for their effort and gives them a certain reputation in society as well as a recommendation for participating in humanitarian operations (Popoola et al. 2013). Higher levels of remuneration include getting equipment for more effective execution of tasks, sending invitation cards for participation in the charity dinners and the like. It is even more important that in this way volunteers acquire a reputation which is crucial in evaluating the evidence. The votes for or against the evidence are more valid if they come from a high-ranking evaluator. The platform takes regular identity checks of all participants, checks of their IP addresses and behavioral patterns, etc. (Popoola et al. 2013).

While the Verily platform is currently only available to humanitarian organizations and certain media, there is another open-source crisis crowdsourcing platform on the Internet. It is called Ushahidi (<https://www.ushahidi.com/>). The platform was created as a spontaneous response of engaged Internet users on the occasion of the crisis which occurred due to the violence that erupted after the democratic elections in Kenya in 2007 and 2008. This crowdsourcing platform helped to map the crisis online using a graphical representation of violence and its magnitude in order to attract the attention of the global community (Okolloh, 2009). The platform has created an open access to events and enabled population to publish evidence in order to overpower a false media image of riots presented by the state-controlled media (Dietrich & Pawlak, 2013). After that current initiative the platform has matured into a global non-profit technology and in this way institutionalized the Ushahidi platform. Today the platform provides crowdsourcing support in 31 foreign languages and so far it has produced over 60,000 successful interactive mappings such as those in Chile and Haiti after the devastating earthquakes and those produced due to the human rights violation and the escalation of violence in India, Pakistan, the Philippines and South Africa. Currently it does the interactive mapping of the ethnic hate speech. It is considered to be an early warning mechanism that can help governments to proactively mitigate discontent and crisis (Ayao, 2014). On the project sites it has been pointed out that so far 6.5 million posts or testimonies has been collected and that 20 million people has been reached. The Japanese version of the Ushahidi platform, called Sinsai.info (<http://www.sinsai.info/>), was created only 4 hours after the devastating earthquake in 2011. It allowed people to geotag, map reports from Twitter and categorize them according to the types of disposable resources: evacuation shelters, food stores that work, petrol and phone charging stations. The authors (Dietrich & Pawlak, 2013) consider the crisis in Haiti to be the catalyst of the idea that the knowledge of affected population is the key to effective crisis management operations. The profiling of ad hoc worldwide crowdsourcing initiatives has led to their gradual institutionalization in a form of associations such as SBTF (Standby Task Force) which join thousands of crisis mappers from some 70 countries worldwide. The Mulder's team (Mulder, Ferguson, Groenewegen, Boersma & Wolbers, 2016) states that when the crisis develops it is a great challenge to meet the information needs of humanitarian responders. In such situations an access to updated information on physical layout of the affected area, the location of the vital infrastructure and services is essential. In such situations the maps are of great importance, but according to the authors (Mulder, Ferguson, Groenewegen, Boersma & Wolbers, 2016) in rapidly urbanized developing countries the existing maps that are used by the government often do not correspond to the situation that is constantly changing. A difference between crowdsourcing interventions in Haiti in 2010 and in Nepal in 2015 has been noticed. The latter is considered to be more successful because it created information loops in which the processed information returned back to the affected population as well as to other participants, so that the development of the platform is unquestionable (Mulder, Ferguson, Groenewegen, Boersma & Wolbers, 2016). According to the authors (Zipf & Khazai, 2016) the analysis after Nepal's disaster has proved that the common people can help in finding the right response to the crisis situation and are able to organize among themselves and outside national borders. According to (Liu, 2014) the thing which is missing in the field of crisis informatics is a conceptual scientific network for integration and operationalization of the crisis crowdsourcing in the official domain of crisis management. Recently, the authors (Zipf & Khazai, 2016) have indicated the development of the scientific framework of Crowdsourcing for Forensic Disaster Analysis (Crowd FDA) and its new methods. According to the authors its operationalization in future emergencies is expected. The authors (Frigeiro & Bossi, 2016) have announced two pilot studies of the development of mobile application Mappers (Mobile Application for Emergency Response and Support) which relies on people as crowdsourced mappers through the use of application. The first study involves data collection from the local

population affected by floods and the other one tests pre-emergency actions on the ground with rescue teams collecting data about possible hazards. 75% of the costs relating to the development of the above mentioned application are financed by the European Commission, Department of European Civil Protection and Humanitarian Aid Operations (ECHO, 2013). During the pilot study the redesigning of the application based on methodological and technological knowledge is also expected. The author (Harrison, 2016) compares the acceptance of the crowdsourcing idea in government agencies in Canada and the US and comes to the conclusion that the implementation of crowdsourcing in crisis management has progressed more in the United States than in Canada where agencies are still reserved towards the credibility of the information coming from members of the civilian community. The Canadian government considers organizational factors, demographic factors and hazards to be barriers for the successful implementation of crowdsourcing in the entire cycle of crisis management (Harrison, 2016). The author concludes that the agencies which have more experience and are mentoring related to crowdsourcing more deeply implement this practice in the crisis management system, while agencies with less experience see the benefits of this approach, which are constantly proven in the literature, but still have barriers to full implementation. Understanding and characterization of these barriers and constraints is the first step in successful development and launch of government crowdsourcing applications, especially in Canada (Harrison, 2016).

6. CONSLUSION

The paper gives insight into the problems of the use of crowdsourcing in crisis management. A number of authors have contributed to the development of the platforms and models for collection, analysis and evaluation of data which have been produced during the crisis and distributed by the population through the Internet or mobile applications and social networks, of which the most common is Twitter. We have presented the problems of data processing that cannot be solved only by hardware but have to be the subject of human and machine processing in order to verify the authenticity and labelling of the data which is easier overcome by machine learning and distributed to government agencies and humanitarian organizations as well as back to the local population. It has been noted that the governments are aware of the contribution which crowdsourcing can bring to the crisis management practice. The scientific framework which will thoroughly evaluate the crisis management practice and explain how to achieve implementation has been in plan but has not been created yet. Governments are expected to develop new crisis management policy accordingly. It has been recommended to the Croatian government and government agencies to study the best practices in foreign countries prepare and localize applications and systems for communicating and processing of data and conceive crowdsourcing as an extremely important tool in the future crisis management.

LITERATURE:

1. Alsever, J. (2007). What is Crowdsourcing? *MoneyWatch*. Available at: <http://www.cbsnews.com/news/what-is-crowdsourcing/> [accessed 12. Jan. 2017].
2. Ayao, T. (2014). Ushahidi Crowdsourcing Platform: A People-Centered Approach to Conflict Transformation in Kenya. Available at: http://forums.ssrc.org/kujenga-amani/2014/09/26/ushahidi-crowdsourcing-platform-a-people-centered-approach-to-conflict-transformation-in-kenya/#.WIzyh_JmmuS [accessed 20. Dec. 2016].
3. Bontcheva, K., Derczynski, L., Funk, A., Greenwood, M.A., Maynard, D. & Aswani, N. (2013). Twitter: An open-source information extraction pipeline for microblog text. In *RANLP Proc. of IS-CRAM, Baden-Baden, Germany*.

4. Cameron, M.A., Power, R., Robinson, B. & Yin, J. (2012). Emergency situation awareness from Twitter for crisis management. In *Proc. of the 21st international conference companion on World Wide Web*.
5. Castillo, C. (2016). *Big Crisis Data: Social Media in Disasters and Time-Critical Situations*. Cambridge: Cambridge University Press.
6. DARPA NETWORK CHALLENGE: PROJECT REPORT. (2010). Available at: <http://www.eecs.harvard.edu/cs286r/courses/fall10/papers/ProjectReport.pdf> [accessed 11. Jan. 2017].
7. Dietrich, C. & Pawlak, P. (2013). Crowd-sourcing-crisis response in the digital age, *European Union Institute for Security Studies*. Available at: http://www.iss.europa.eu/uploads/media/Alert_Crowd-sourcing.pdf [accessed 3. Jan. 2017].
8. ECHO European Civil Protection and Humanitarian Aid Operations. (2013). Available at: http://ec.europa.eu/echo/funding-evaluations/financing-civil-protection-europe/selected-projects/mobile-application-emergency_en 2013, [accessed 22. Dec. 2016].
9. Foster J. et al. (2011). #hardtoparse: Pos tagging and parsing the twitterverse. In *AAAI 2011 Workshop on Analyzing Microtext*.
10. Frigerio, S.L. & Bossi, G. (2016). Crowdsourcing with mobile techniques for crisis support. *PeerJ Preprints*.
11. Han, B., Cook, P. & Baldwin, T. (2013). Lexical normalization for social media text. *ACM Transactions on Intelligent Systems and Technology (TIST)*.
12. Harrison, S.E. (2016). Crisis Crowdsourcing in Government: Characterising efforts by North American Agencies to Inform Emergency Management Operations. *UWSpace*.
13. Imran, M., Castillo, C., Diaz, F. & Vieweg, S. (2015). Processing social media messages in mass emergency: A survey. *ACM Computing Surveys (CSUR)* 47(4). Article No. 67.
14. Imran, M., Elbassuoni, S.M., Castillo, C., Diaz, F. & Meier, P. (2013). Extracting information nuggets from disaster- Related messages in social media. In *ISCRAM 2013 Conference Proceedings - 10th International Conference on Information Systems for Crisis Response and Management*. Karlsruhe Institut fur Technologie.
15. Imran, M., Mitra, P. & Castillo, C. (2016). Twitter as a Lifeline: Human-annotated Twitter Corpora for NLP of Crisis-related Messages. In *Proceedings of the 10th Language Resources and Evaluation Conference (LREC), Portorož, Slovenia*.
16. Liu, S. (2014). Crisis Crowdsourcing Framework: Designing Strategic Configurations of Crowdsourcing for the Crisis Domain. *Journal of Computer-Supported Cooperative Work special issue on Crisis Informatics and Collaboration*. 23(4-6).
17. Mulder, F., Ferguson, J., Groenewegen, P., Boersma, K. & Wolbers, J. (2016). Questioning Big Data: Crowdsourcing crisis data towards an inclusive humanitarian response. *Big Data & Society*.
18. OECD. (2013). *Risk Management: Strategic Crisis Management*. Available at: <http://www.mmc.com/content/dam/mmc-web/Files/Strategic-Crisis-Management-paper-July-2013.pdf> [accessed 10. Jan. 2017].
19. Ofli, F. et al. (2016). Combining Human Computing and Machine Learning to Make Sense of Big (Aerial) Data for Disaster Response. *Big Data*. 4(1), 47-59.
20. Okolloh, O. (2009). Ushahidi or "testimony": Web 2.0 tools for crowdsourcing crisis information. In *Participatory Learning and Action 59 Change at hand: Web 2.0 for development*.
21. Palen, L. et al. (2010). A Vision for Technology-Mediated Support for Public Participation & Assistance in Mass Emergencies & Disasters. In *Proceedings of the ACM-BCS Visions of Computer Science Conference*.

22. Popoola, A. et al. (2013). Information verification during natural disasters. In *22nd International World Wide Web Conference, WWW '13, Rio de Janeiro, Brazil*. pp. 1029-1032.
23. Potts, L. (2014). *Social media in disaster response: How experience architects can build for participation*. New York: Routledge, 2014.
24. Purohit, H., Castillo, C., Diaz, F., Sheth, A. & Meier, P. (2014). Emergency-relief coordination on social media: Automatically matching resource requests and offers. *First Monday*. 19(1).
25. Questia (2017). <https://www.questia.com/library/communication/rhetoric-and-public-speaking/crisis-management-in-government> [accessed 11. Jan. 2017].
26. Retrieve. (2017). <https://www.retrieve.com/blog/the-role-of-mobile-technology-in-crisis-management> [accessed 9. Jan. 2017].
27. Vieweg, S.E. (2012). *Situational Awareness in Mass Emergency: A Behavioral and Linguistic Analysis of Microblogged Communications*. Available at: <http://works.bepress.com/vieweg/15/>
28. Zipf, A. & Khazai, B. (2016). Crowdsourcing for Forensic Disaster Analysis. Available at: https://www.heika-research.de/english/627_636.php [accessed 21. Dec. 2016].

REVITALIZATION OF INDUSTRIAL ZONES OF THE BIG CITY (EVIDENCE FROM THE CITY ODESSA)

Irina Pedko

*Odessa State Academy of Civil Engineering and Architecture, Ukraine
31318ip@gmail.com*

Anastasiia Pandas

*Odessa State Academy of Civil Engineering and Architecture, Ukraine
anastasyandas@gmail.com*

ABSTRACT

The vector of sustainable development of modern urban space is the creation of a system of private-public partnership (power, business, population), which allows linking processes of spatial development of the city with the interests of development of local territorial communities. The contradiction between the existing urban environment and the new needs of society can only be solved by qualitative transformation of existing dysfunctional urban spaces, namely, industrial zones, their revitalization. The transformation and development of degrading industrial territories is one of the most urgent tasks in the sphere of spatial development for each city. However, this issue should be solved systematically by developing a comprehensive policy for the development of depressed areas of the city. The comprehensive plan should determine the ratio of zones of different purposes in the central part of the city, the development of transport and communal infrastructure in the urban agglomeration. This process allows you to control effectively the development of a spatial environment that will stop the accumulation and growth of irreversible chaotic processes within the city system, will help create new areas of gravity and give impetus to the development of entire areas.

Keywords: *city, spatial development, reconstruction, modernization, revitalization, functional zones*

1. INTRODUCTION

In the system of economic regulation of the land use, the issue of improving the structure and increasing the efficiency of the use of urban areas up to this time has not been given due attention. The development of the property institute, the increase in demand for housing and other property objects within urban areas have resulted in increased attention to the development of organizational and economic principles for the improvement and use of this group of lands. The question of the restoration of urban areas began to focus attention since 1958 after the first international seminar on the reconstruction and modernization of cities, which was held in Hague, it was proclaimed that the main goal of the renovation of cities is a conscious change in the urban environment and the creation of modern living and working conditions for citizens. transformation of existing spaces [5]. This event marked the vector of development, the understanding of the need to plan and develop reconstruction programs in more detail, began to focus on social and rehabilitation of disadvantaged areas to new economic and social demands of society, comfort of living. Sustainable urban development involves the formation of a harmonious environment, which provides comfortable conditions for all processes of human vital activity. This is, so-called, socially, economically and environmentally balanced development aimed at:

- rational use of resources (natural, labor, industrial, scientific, technical, intellectual);
- technological re-equipment and reconstruction of enterprises, improvement of social, industrial, transport, communal-information, engineering, ecological infrastructure;

- improvement of the residential and landscape recreation component of preservation of architectural and cultural heritage.

The trends of development of Ukrainian big cities are the centralization of labor resources, capital, investments. In the country, the nature of spatial processes has changed, where the economic and social interests of private economic actors has dominated the position, from the point of view of the choice of territories for their own needs, business, and investments are subject to market laws. Present requires a reasonable balance of interests of all participants in spatial relations: city authorities, entrepreneurs, residents of the city. The effectiveness of using of urban areas is uneven. It depends on the size of the city, its national economic profile, the level of development of engineering, nature conservation and social infrastructure, natural, environmental and other regional factors, as well as the conditions for the placement of specific areas in the city plan. The size of the assessment of territory of the settlements is dynamic, varies over time and, mainly, increases. Therefore, the boundaries and requirements for the establishment of functional zones varies depending on how changes in their priority use occur. However, the mechanism of functioning of the municipal system is still not productive, the outdated infrastructure is used, which complicates the mobility of the population, there are no multifunctional high-efficiency territorial clusters, ecologization and aesthetization of the urban environment. The solution of these problems is related to the development and implementation of a comprehensive innovative strategy of spatial reconstruction of cities, aimed at the harmonious development of territorial complexes in order to create a qualitative humanistic environment of human life. Structural reorganization provides the rational use of the city's potential and adapts urban space to market conditions. In modern conditions, the practice of spatial reconstruction of large cities with the help of renovation of industrial zones became relevant. Construction and creation of territories that are free of industrial development, saturated with public, residential, entertainment and commercial functions, important both for the ecology and for the city budget, in order to attract additional investments. The problem of reconstruction in economic terms is accompanied by changes that are taking place in creating conditions for the effective functioning of the priority users of regional economic resources with the determining role of demand, first of all, of the local population. Constant changes in the needs of urban populations can be considered in two aspects. First, it is an attitude to the implementation of the primary function of cities – the use of them as a medium for life and activity. Continuous socio-economic changes cause further changes in the spatial structure of the city, the adaptation of old elements to new conditions, if they are viable, as well as the disappearance of non-viable and manifestation of new spatial structures, that is, the continuous reconstruction of the city. Secondly, a person as a biosocial object does not exclude the preservation of historical, cultural and landscape-ecological potential. In addition, it should be borne in mind that the main aesthetic values of the urban environment belong to old buildings. The ambiguity of the criteria for assessing the historical and urban heritage has led to different approaches and definitions in relation to reconstructive measures. The most commonly used are the following: restoration, reconstruction, modernization, revitalization [1].

2. THEORETICAL BACKGROUND OF THE RESEARCH AND METHODOLOGY

Restoration – scrupulous restoration of the original appearance of the building, the construction, transforming it into a museum object, the constant maintenance of this state [10]. Reconstruction – adaptation of existing building to new functions and needs with the maximum possible preservation of the environment, architectural forms, facades and interiors [9]. There are key areas for reconstruction [3,7]:

- formation of compound building without demolition of existing buildings and structures (in order of consolidation of building);

- renovation of existing housing, with partial demolition of residential or public buildings;
- development of the situation, and the formation of a new building with a partial preservation of valuable buildings.

Modernization is a reconstruction, which is accompanied by the active introduction of new elements [11]. Revitalization (from lat. re - again, and vitalis - life, new life) is a complex of reconstruction and restoration measures aimed at the effective use of objects in modern conditions. Another definition can be considered - adaptation with a change in the functional purpose of industrial zones, which involves the consistent transformation of the material and aesthetic environment as a city in general, as well as the development of a separate neighborhood, quarter, object. In world practice, revitalization is the most optimal way of transforming abandoned areas into industrial zones, as well as more efficient and its economically attractive use. At the same time the most important tasks find it's own solution:

- restructuring of the planning and urban structure of industrial zones in large cities;
- ordering transport and pedestrian connections of the territory;
- raising the level of urban improvement and landscape organization of the environment;
- change of functional assignment of adjacent territories;
- solving ecological problems;
- improvement of aesthetics and ensemble integrity of building of streets or squares.

The third aspect of regulation of social and economic activity within urban areas is the methods and forms of control over the condition of the urban environment, which involves organizing activities related to both the maintenance of its engineering and construction operating condition and the preservation of socio-cultural and landscape- ecological potential. A distinctive feature of the functioning of the industrial complex of Ukraine, of the last period, is a deep decline in production and the plant shutdowns. Nowadays, the technical condition and degree of moral depreciation of industrial potential of Ukraine is such that the expediency of reconstruction of it with the preservation of the initial functional purpose by the technological, technical and technical and economic indicators is problematic [8]. This circumstance is confirmed by the existing practice of reconstruction of industrial development with a change in the functional purpose of buildings and industrial enterprises. The problems of developing a modern large city consist in the lack of territorial reserves. In the general plan of Odessa to ensure the city's perspective needs, a clear direction was adopted, aimed at intensifying the use of intra-urban territorial resources in the existing administrative boundaries of Odessa. As it was noted by American economist W. Rogers: "The trouble with the earth is that it is no longer doing it." In total, according to the functional purpose, according to DBN 360-92 ** 91.5% of urban land is used. Free from the development of the territory, make up 8.5%. Production areas (industrial enterprises, communal-warehousing, construction organizations and special territories) occupy about 18% of the city's land. Functional zones within urban areas have signs of mono- and polyfunctional use. The regulation of the latter is based on the priority of the main objects of economic activity, with the maximum profitability, based on the use of natural resource potential within a specific zone. However, whole targets can not be provided on a self-regulation basis. In market conditions, the resolution of conflict situations over the use of various economic resources, including land, is achieved by state intervention. In this case, the interests of the priority users and the state should be unidirectional, otherwise it is impossible to obtain the maximum efficiency of using the specified resources. In addition to the expressive representatives of the functional use of the territories, it is necessary to distinguish the types of activities that need to include objects of the economic sectors complementing the functional use of the territories defined as neutral or subordinate (Figure 1).

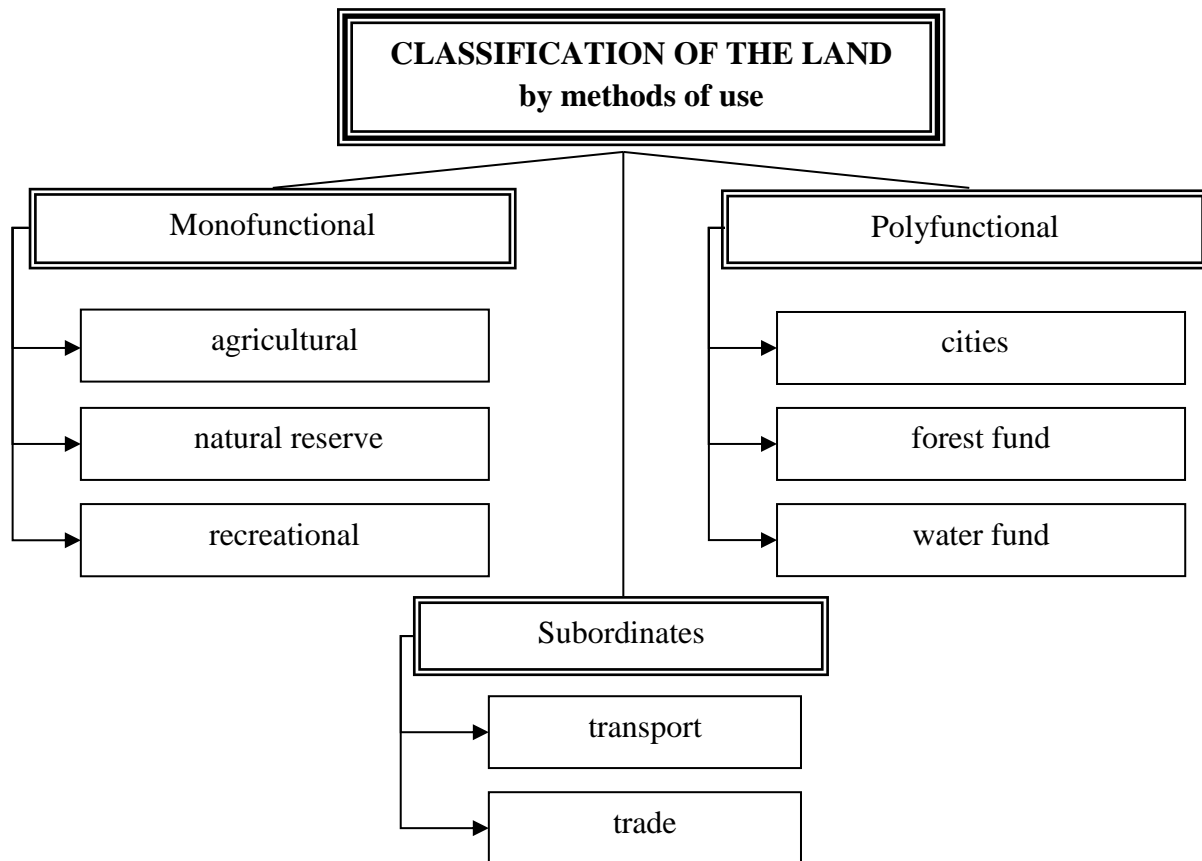

Figure 1: Classification of lands by methods of use

This is largely attributable to the activity of transport and, accordingly, specific features of the allocation of land transport to other users. This feature is related to the fact that transport by function, as a rule, is included in the complementary or service sectors of regional distribution. However, the necessity and economic expediency of the placement of buildings and other objects of transport is determined by the fact that this branch belongs to natural monopolists. The boundaries of urban development, in addition to residential buildings, are divided according to the following features of functional use [6]: industrial areas, external transport, communal warehouse territories, sanitary protection strips, water surfaces, inappropriate territories, other territories. It should be noted that the industrial zone is understood as the part of the city where the enterprises and associated facilities together with the areas of sanitary protection zones, as well as other cities, are applied. O. Demidova defines: "Industrial zone is a territorial formation in the structure of the city, formed on the basis of a group of industrial enterprises, technologically related or not related to each other, having common engineering communications. In a city framework industrial areas are enclaves, little or no connection with an adjoining territory, different from the surrounding scale. They are part of the city and at the same time, they are relatively autonomous: there are practically no functional and social links with the surrounding buildings, with the exception of some number of workers from local residents" [12]. Modern problems of the functioning and development of industrial zones are a consequence of the urbanization policy of industrialization and the systemic socio-economic crisis of the post-Soviet period carried out in the Soviet period. The urbanization policy of the industrialization of the Soviet period envisaged a high concentration of large industrial enterprises in cities, regardless of what profile functions were characteristic of these cities [4].

3. RESULTS AND DISCUSSION

Analyzing the course of the history of the spatial development of Odessa, we can conclude that mass development of territories for industrial development is a result of the intensive development of industrial production. For example, in 1879 there were 159 enterprises in Odessa, and in 1890 there were 322. Construction continued during the Soviet Union, during the period of industrialization. Industrial areas and individual enterprises merged into the giant industrial formations. Industrial zones were formed quite heterogeneously in their composition and branch content, they were of mixed character. Along with the enterprises of the city-forming subsystem there were city-service enterprises, communal, transport and warehouse facilities, research institutions. However, at that time industrial zones were outside the city and under the influence of urbanization processes, many industrial enterprises were within the city, and some even in the central part of it, deeply incorporated into the city structure. To date, one of the negative consequences of the active period of industrialization of Odessa is the industrial zone "Peresyp" – a huge, slightly populated area, which is in contact with the Black Sea water and irrigation fields, being currently in an abandoned state and is the most destitute territory of the city. The territory of Peresyp is located in the central area and is strategically important from a transport point of view. There is a unique highway connecting the township named Kotovsky with other areas of the city and the most important railway line with several stations. In addition, part of the coast at Peresyp is seaports. The industrial zone "Peresyp" has lost its significance under the influence of changing economic conditions and today has a large urban development potential, its revitalization will improve city-planning, ecological, visual and other characteristics, will allow to create an organic architectural and landscape environment of the city. Improvement and rationalization of the Pereship industrial zone, the introduction of new alternative functions in this territory will have social, economic, environmental and aesthetic effects. However, it is important to note the importance of the development of this territory on the basis of a cluster principle, which will ensure the combination of business, science and production. Thus, production sites will turn into high-tech space, for example, united industrial parks or residential blocks, civil and green zones. The industrial zone "Peresyp" has lost its significance under the influence of changing economic conditions and today has a large urban development potential, its revitalization will improve city-planning, ecological, visual and other characteristics, will allow to create an organic architectural and landscape environment of the city. Improvement and rationalization of the Pereship industrial zone, the introduction of new alternative functions in this territory will have social, economic, environmental and aesthetic effects. However, it is important to note the importance of the development of this territory on the basis of a cluster principle, which will ensure the combination of business, science and production. Thus, production sites will turn into high-tech space, for example, united industrial parks or residential blocks, civil and green zones. Modern industrial zones in the developed countries of the world are mobile systems that are as susceptible to change. This is a flexible, often modular production with a high level of unification and standardization of equipment and production operations. Its operation, the ability to quickly reconfigure operations and technological modernization is supported by a complex of sub-sectors, which provide production of all necessary. Such production systems are easily replicated and transferred from one territory to another [4]. There is already an experience of the renaissance of former industrial enterprises in Odessa; in the past, the tea-making factory turned into a center of contemporary art, the Tea Factory; the premises of the steel enterprise "Stalkanat" were completely rebuilt into the art space, while part of the territory of the complex Krajan was revitalized in Center for integrated services for the city's population, related to administration, social protection, pensions, employment and others. However, these transformations are dot-like, there is no experience, nor in Odessa, nor in Ukraine as a whole in the complex revitalization of large industrial zones.

To effectively achieve this goal, a city program or strategy for the revitalization of abandoned industrial zones with a mechanism for implementing functional changes, the development of an infrastructure plan and the preparation of investment proposals and projects should be developed. This occasion will allow to improve the condition of the city environment, to compare it with resource resources of the territories and economic opportunities of their realization, will allow to revive the real estate market. In our view, the revitalization of the industrial zone "Peresyp" should turn it into a multifunctional public area, which would include:

1. High-tech and environmentally safe production;
2. "creative clusters" (art zones) - centers of contemporary art, for various events (exhibitions, performances and festivals);
3. business parks, business centers;
4. cultural and entertainment centers;
5. residential complexes;
6. recreational zones.

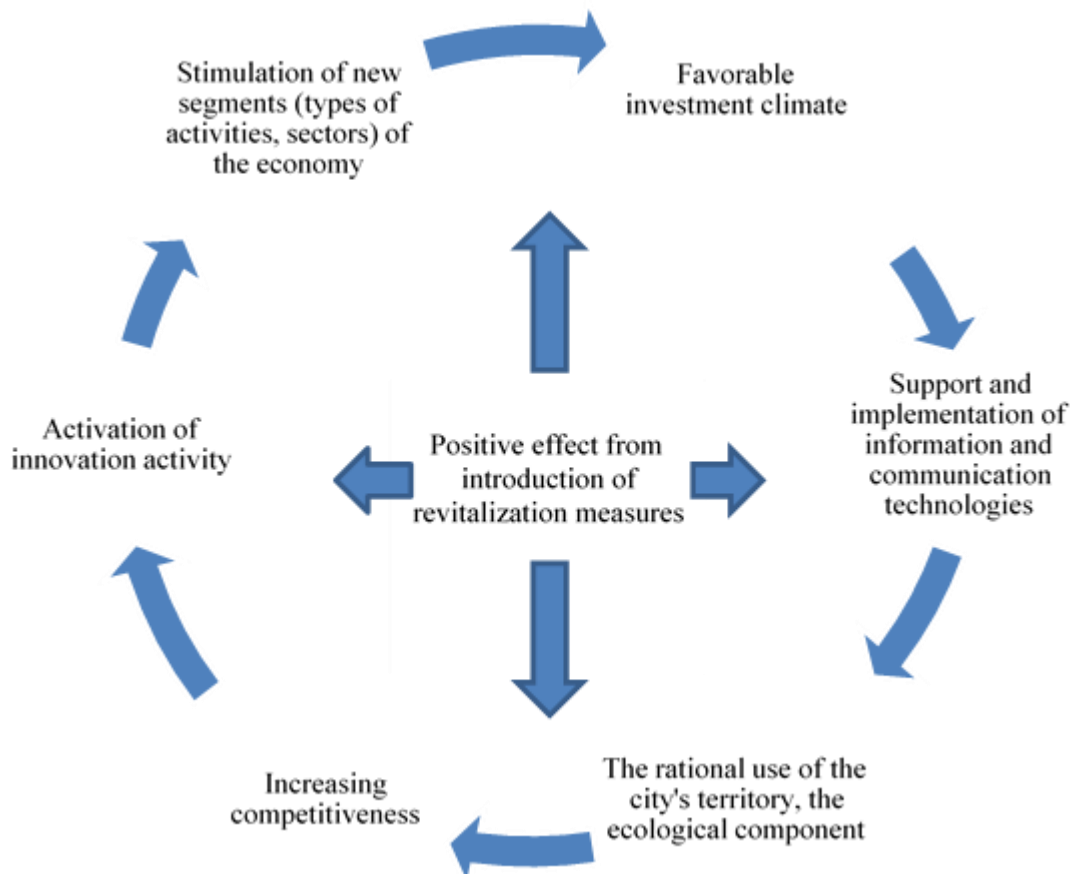

Figure 2: Socio-economic effect from the introduction of revitalization measures

4. CONSLUSION

In this connection, the main principles which should be the basis of revitalization measures become important:

- complexity. Determines the need to address all planning issues with complex consideration and resolution of each issue, taking into account all other principles, as well as planning factors;
- socio-economic. Accounting for cost-effectiveness, as well as a non-negligible component, is the social effect;

- planning. At the same time, the main task is to correctly recognize such a development perspective, which makes it possible to use all potential features and features of the enterprise.

The territorially – spatial development of the city should be directed to the development of the most investment attractive, significant territories and main units of the city structure. Through a comprehensive reconstruction and revitalization of old buildings are solved not only urban but also social task of providing the population with the necessary institutions, creating a complete structure of housing and service, comfortable urban infrastructure, modern accommodation in attractive areas of the city, environmental safety, preservation of cultural heritage and attraction public in the life of the city.

LITERATURE:

1. Akhmedova, E., Shabanov. V. (1989). *Urban Environment: Problems of Reconstruction*. Publishing house.
2. Demidova, E. (2013). Industrial territories in the framework of urban fabric: the concept, localization factors, development trends.
3. Gavrilov, I. (2004). On urban planning approaches to the reorganization of territories. *Construction, Material Science, Engineering*. PGAASA. 27, 22 – 25.
4. Homonai-Strizhko, M. (2009). *Restructuring of the territorial-vibrochnykh utovoren of the Great Monastery*. Institute of Regions, NAN of Ukraine.
5. Kasyanov, V., Tabakov, V. (2011). Experience of foreign countries in the field of urban development reconstruction. *Vestnik MSSU*, 8, 21–27.
6. Kontorovich, I., Rivkin, A. (1986). *Rational use of urban areas*. Stroiizdat.
7. Krashennikov, A. (1988). *Historical Quarter*. High School.
8. Osipov, A., Osipova A. (2015). Revitalization of populated areas. *Urban planning and territorial planning*, 58, 365 – 371.
9. Shepelev, N., Shumilov, M. (2000). *Reconstruction of urban buildings: Textbook. for builds. specialist. universities*. High School.
10. Volkova, T. (2014). *Rehabilitation of urban living environment. Social and town-planning aspect*. PGUAS.
11. Volkova, T. (2008). Rehabilitation of degrading living environments. *Theory and practice of environmental design*, 38 – 40.

SELECTING AN OPTIMAL STRUCTURE OF CO-BRANDING ALLIANCE FOR AN INTEGRATED BUSINESS STRUCTURE

Valeriia Shcherbak

*Kyiv National University of Technologies and Design, Ukraine
Nemirovich-Danchenko Street 2, Kyiv 01011
valery_shcherbak@i.ua*

Olena Nifatova

*Kyiv National University of Technologies and Design, Ukraine
Nemirovich-Danchenko Street 2, Kyiv 01011
helen_bykhova@live.ru*

Olena Kaliuzhna

*Mykolayiv National Agrarian University, Ukraine
Georgiya Gongadze Street 9, Mykolayiv 54020*

ABSTRACT

Co-branding is an actual trend in the development of integration processes in business, since it reveals a specific form of relationship between internal and external environment in building competitive advantages in the context of integrated business structures evolution and growth. The aim of the study is the selection of an optimal structure of co-branding alliance for an integrated business structure based on the assessment of economic effects from co-branding and evaluation of the brand congruence level. The study presents a comprehensive system of synergistic co-branding strategy development built upon the implementation of a three-stage algorithm. The goal of synergistic co-branding strategy development is attaining such a branding alliance out of all possible alternatives where the economic benefits from a particular brand of integrated business structure will transform into synergistic interaction effects within the co-branding alliance. With the aim of empirical testing the relevance relationships and components of consumer attitudes to co-branding an expert evaluation of potential co-branding alliances for the Fozzy Group integrated business structure has been carried out. Given the brand congruence assessment results in terms of brand relevance and customer expectations indicators, clustering of possible co-branding alliances by the specified criteria has been performed. The evaluation of economic effects from co-branding was carried out among those co-branding alliances which demonstrated the highest level of congruence. To determine the optimal variants for co-branding alliances within Fozzy Group an ABC-analysis has been used. This study provides the rationality that co-branding is a logical follow-up of the innovation process expansion and enhancement of integrated marketing of IBS activities. The emergence of a joint product resulting from such strategic partnership between business units becomes a determining factor in the co-branding strategy and in the context of integrated structures fosters full integration of their marketing mix. From this perspective, building a co-brand seems to be a logical approach and optimal solution for further joint activities of integrated business units.

Keywords: *alliances, brand relevance, co-branding, co-branding customer expectations, congruence, economic effect*

1. INTRODUCTION

Co-branding continues the difficult complex of theoretical-methodological problems, which are not yet solved by the marketing science from the position of approach of the systems. Central to them is the question of choosing a partner to form a co-branding strategic coalition, which will provide an opportunity to obtain a positive synergistic effect in terms of congruence of

brands of integrated formation. The feasibility of such an association is due to the desire of the integrated business structure to realize the synergetic potential through co-branding by capitalizing the strengths of each brand, which are united in a marketing strategic alliance. Nowadays, co-branding strategies of integrated business structures are becoming very popular. Co-branding is a reciprocal use of marketing channels by several business units aimed at developing a market niche, when the overall effect exceeds the result of using the same channels by each business unit separately. However, the relation to co-branding is ambiguous as there is a probability of getting a negative synergistic effect as a result of implementation of such strategies. Therefore, the positive synergistic effect of co-branding strategy directly depends on timely and reliable support of the marketing information of the integrated business structure company, which should be primarily focused on choosing a congruent partner for co-branding. Thus, the purpose of this study is to develop the principles of choosing the optimal structure of a co-branding alliance integrated business structure on the basis of determining the level of economic effect of co-branding and assessment of the level of congruence of brands.

2. LITERATURE REVIEW

Since co-brands are derivatives of brands and arise as a result of combining two (or more) previously unrelated trademarks into a single entity – a common brand, their definition is associated with relevant methodological peculiarities. An approach to understanding co-brands as a «product» of consumer's cognitive activity [1], which results in the formation of new associative ties in his mind, explains why common branding requires the creation of deeper interrelationships between brands than a simple combination of names and sharing logos. Stable ties are designed to provide a synergistic effect for the consumer in the context of different products, values and ideas, which represent individual brands. By term of lacking strong content ties between brands, which are involved in the implementation of co-branding strategy, the consumer can't see the value of the association and feel the effect of synergy [2]. Therefore, in view of above mentioned understanding of brands and co-branding, the methodological basis for the formation of competitive advantages in the integrated growth of business structures in the process of implementation of co-branding strategy should become approaches that allow the logical and patterns explanation of establishing in the minds of consumers associative links between brands that were united with a joint co-brand. Under the influence of advertising and in the process of testing goods and services in the minds of the consumer there are certain stable structures – «product images» and «images of brands», which during the process of their formation begin to influence on the judgments about the product. As noted in the works of Lee Ch. And Decker R., the images organize the perception of the object, forming certain expectations in relation to it [3]. The images of brands are the derivative level of product images and, as a rule, contain the main features of those of them, which are prototype to brands. In accordance with the mechanisms of schematization, any new information that becomes available to the consumer, activates the existing images of products and brands and is interpreted in accordance to them. In this sense, co-branding is closely linked with the processes of transformation of already formed images and the creation of new ones, because the consumer has to perceive the fact that two brands operate in the market together and to assess whether such a union is congruent or non-congruent [5,6]. In works devoted to co-branding, you can find a wide variety of terms by which their authors indicate the connection, relevancy, similarity, compatibility and authenticity of brands in the strategic marketing alliance. However, the nature of the tradition has gain the usage of category «perceived conformity», borrowed from the works of Aaker D. and Keller K.L and is used in the English literature on co-branding [7,8]. The search of the underlying causes of the importance of matching brands to make a successful strategic marketing alliance, determined the choice of a psychological paradigm of congruence as a methodological basis for the definition of an «optimal» partner

for branding. Consequently, the essence of conformity of brands within the framework of the integrated formations is revealed through the categories «congruence» and «incongruity» [9]. Congruence is a bi-spatial concept that includes two components: expectation and relevance. Expectations reflect the opinion of people about the development of events in the future, depending on the existing ideas in their minds. From this point of view, the level of congruence is determined by the extent to which new information about events and objects coincides with the already existing picture [10]. Relevance involves the presence in the interaction of various objects of a certain logic, which allows you to establish a match between them with the help of associations. In this sense, congruency depends on the extent to which the new information contained in the incentives promotes the consolidation of existing cognitive schemes or threatens their erosion. Based on this understanding of congruence, Fleck N, Michelle J., Gattinon H emphasize that each of its components focuses on the component of consumer attitude to the association of brands. The process is dual in nature. From the point of view of modern theory of consumer behavior, the attitude of the consumer to the object (product, brand) is determined by his thoughts (cognitive component) and feelings (affective component) about it. The cognitive components reflect the consumer's beliefs about the brand, which are based on knowledge of its attributes, and determine the degree of consumer confidence that the brand meets the characteristics stated in it. In turn, the affective component reflects the emotions and emotional reactions caused by the consumer brand [11]. Based on this, Fleck and her colleagues believe that brand relevance will form a cognitive aspect of co-branding, determining the level of perceived consumer confidence in their association. According to them, the low level of relevance, which means consumers are not able to see and understand the relationship between brands and, as a result, explain the logic of their association, based on the existing knowledge and representations about brands, will lead to a high level of distrust to their association. In turn, expectations will determine the affective component of consumer attitude to co-branding, meaning that consumers will percept in the alliance a certain level of novelty or non-trivial combination of brands. Therefore, to obtain emotional satisfaction from co-branding, a certain level of incongruence is needed, which will shape the feeling of a new and unusual combination of brands, making their alliance attractive to consumers [11,12,13]. While developing a dilemma concerning co-branding congruence, we can mention an interesting hypothesis that the result of co-branding, called a congruent, which corresponds to the consumer's expectations of the brand's alliance, will be the consolidation of stereotypes of its perception, the enhancement of well-known to the consumer characteristics through «repetitions» in the alliances with «affiliated» companies [14]. At the same time, in our opinion, multifaceted congruence of co-branding is most fully discovered through the understanding of its dichotomy, which is realized through the brand's relevance and consumer expectations. Thus, the best consumer estimates of co-branding can be predicted in a situation of low expectations and high level of relevancy, which allows us to represent the hypothesis that the alliance of such brands will be the most successful in the market.

3. THE METHODOLOGY OF OPTIMAL STRUCTURE OF THE CO-BRANDING ALLIANCE OF INTEGRATED BUSINESS STRUCTURE CHOICE

The methodology of optimal structure of co-branding alliance of integrated business structure choice is based on the implementation of a three-stage algorithm. The purpose of already mentioned methodology is to obtain such a branding alliance of all possible, in which the economic effects of individual brands of the integrated structure will turn into a synergistic interaction effect in the middle of the co-branding alliance. According to this concept, the following algorithm is proposed (Figure 1). So, let's move on to assess the level of congruence of the brand under typical conditions (brand relevance, consumer expectations). It should be noted that with the help of the typical conditions developed by us, it is possible to determine

the following levels: "low", "medium" and "high". Such an assessment is implemented with the help of a score, which is adjusted to the significance of the criterion. Its purpose is to determine the level of congruence of brands by the following components: relevance of the brands of the integrated business structure; consumer expectations. In order to increase the reliability and objectivity of the evaluation results, sub-systems of brand relevance of the integrated business structure were identified within each component. Thus, the following components were detached: product characteristics, brand competitive position, relations with suppliers, intermediaries and distributors, consumers, personnel, communications. The significance of each subcriteria was chosen on the basis of scientific works on expert methodology in the development of score scales [15]. The relevance of brands (X) is determined by the total score, which is represented by the scale of results (Table 1), and is calculated by the following formula:

$$X = \sum_{j=1}^6 \sum_{i=1}^n p_{ij} \times a_{ij} , \quad (1)$$

where - p_{ij} the significance of i -th subcriterion for the j -th criterion, $p_{ij} \in [1..3]$; a_{ij} - the score of i -th sub-criterion for the j -th criterion, $a_{ij} \in [1..3]$; i – quantity of subcriteria, $i \in [1..n]$; j – quantity of criteria, $j \in [1..6]$; $X \in [45..135]$.

The move of the interval is determined by maximum and minimum values of the product of significance and the score by all criteria, taking into account the number of degrees of gradation points. So, the interval move can be calculated by the following formula [16]:

$$H = [(\sum_{j=1}^6 \sum_{i=1}^n p_{ij} \times a_{ij})_{\max} - (\sum_{j=1}^6 \sum_{i=1}^n p_{ij} \times a_{ij})_{\min}] \div k \quad (2)$$

Where k – number of degrees of gradation points; H – interval move, $H = \frac{135 - 45}{3} = 30$

Figure following on the next page

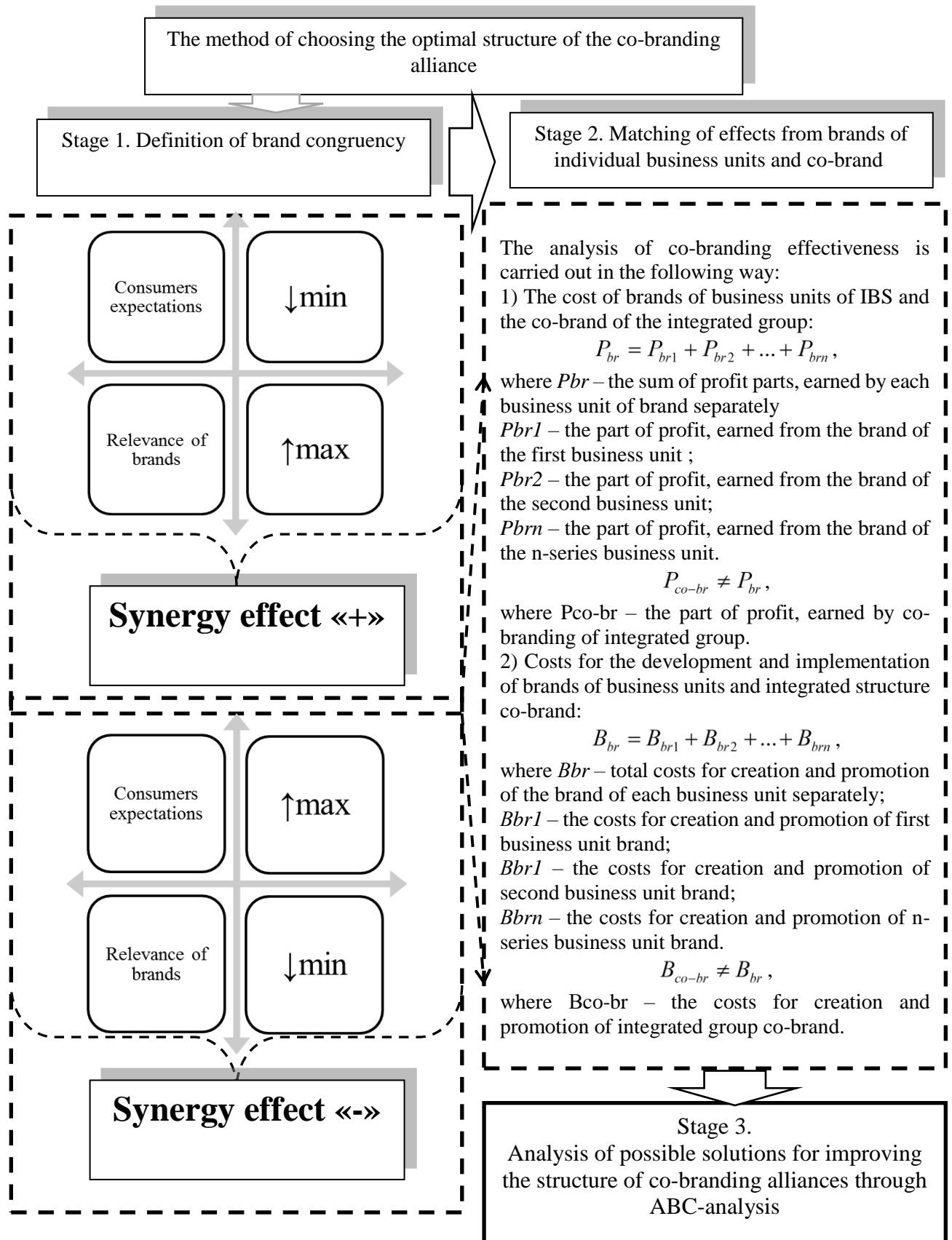

Figure 1: Structure-logical scheme of optimal co-branding alliance structure choice

Thus, if the overall score corresponds to a value ranging from 45 to 75 points, the relevance of brands has low level.

The values ranging from 75 to 105 points characterize the relevance of brands in co-branding alliance as an average, and the interval from 105 to 135 points corresponds to a high level of relevance of brands.

Table 1: The scale of brand relevance assessment in co-branding alliance

Interval values of total estimation of the congruence level	Brand relevance in co-branding alliance
$45 \leq X < 75$	low
$75 \leq X < 105$	average
$105 \leq X \leq 135$	high

Hence, by the criterion of maximizing the relevancy index, we choose the most compatible brands. It should be noted that target associations will include brands with relevance value of depth from 75 to 135 points, that is to say, with high and average relevancy according to the matrix of brand congruency estimation in co-branding alliances. The next step in assessing the level of brand congruence is to determine the assessment of the proposed co-branding alliances by consumers. This criterion is reverse to relevance, in other words, its value is selected by the criterion of minimizing the value. Consequently, according to the matrix of congruent estimation of brands in co-branding alliances of IBSs, target associations will include brands with average and low value of consumer expectations. For the purpose of empirical testing of depicted above relationships of relevancy and components of consumer attitude to co-branding, we will conduct an expert evaluation of potential co-branding alliances for the integrated business structure of «Fozzy Group». The structure has 26 brands, which potentially could be combined into certain co-branding alliances. The results of estimation of congruence level of brands of the integrated business structure «Fozzy Group» are presented in the form of a matrix (Table 2).

Table following on the next page

Table 2: The matrix of estimation of brands congruence level of integrated business structure «Fozzy Group»

	Premia	Dziao	Bank «Vostok»	ringo	trash!	Fozzy C&C	Zonk!	Staromak	Select	Instinct	Extra	PWC	Riki Tiki	Protex	Povna Chasha	U Hrom.Popa	Varto	Bila Romashka	Zelena Kraina	Silpo Voyage	Biodegita	Fora	Silpo	Nizhyn	Lo Silpo
Primia	0	l	l	l	a	h	h	l	l	l	h	h	h	l	h	a	h	a	h	l	a	h	h	h	h
Dziao	l	0	l	a	l	a	h	h	a	a	l	h	a	a	l	h	a	l	l	a	h	h	h	a	a
Bank «Vostok»	l	a	0	a	l	a	l	a	l	l	l	l	l	l	a	a	l	l	l	h	a	h	h	a	a
ringo	l	a	h	0	l	h	l	a	h	l	l	a	l	a	a	a	l	l	l	h	a	h	h	l	h
trash!	l	l	l	l	0	h	l	l	l	l	l	l	l	l	h	l	l	h	l	l	l	h	h	a	a
Fozzy C&C	h	a	l	l	l	0	h	a	h	h	h	h	h	h	h	a	h	h	h	a	a	a	a	h	a
Zonk!	l	a	l	l	l	h	0	h	h	h	h	h	a	a	h	h	a	l	a	a	h	h	h	l	h
Staromak	a	l	l	l	l	a	a	0	a	a	a	h	a	a	a	h	h	l	a	h	h	h	h	a	h
Select	l	l	l	l	l	l	l	a	0	h	h	h	h	h	h	a	h	l	a	l	a	a	a	a	h
Instinct	l	l	l	l	l	h	l	l	l	0	a	h	l	l	a	a	a	a	a	l	l	h	h	a	h
Extra	l	l	l	l	h	a	l	l	l	l	0	h	l	l	a	a	a	a	a	l	l	h	h	a	h
PWC	l	l	l	l	l	h	l	h	a	a	l	0	l	h	h	h	h	l	a	a	h	h	h	a	h
Riki Tiki	h	l	l	l	a	h	l	a	a	l	a	l	0	l	a	a	a	a	a	l	l	h	h	a	h
Protex	l	a	l	l	l	a	a	l	l	l	h	a	l	0	l	l	l	h	a	h	a	h	h	l	h
Povna Chasha	l	l	l	l	h	h	a	l	l	l	a	a	a	l	0	a	h	a	h	l	a	h	h	h	a
U Hrom. popa	l	l	l	l	l	a	l	l	a	l	l	h	l	l	l	0	a	l	a	a	h	h	h	a	h
Varto	h	a	l	l	l	h	l	a	a	l	a	h	l	l	l	h	0	l	h	l	a	h	h	a	h
Bila Romashka	l	l	l	l	l	a	l	l	l	h	l	l	a	h	l	l	l	0	l	a	l	h	h	l	a
Zelena Kraina	l	l	l	l	l	h	l	l	l	l	l	l	a	l	a	l	l	l	0	l	l	h	a	a	l
Silpo Voyage	a	h	h	h	l	a	l	a	a	a	l	h	a	l	l	h	l	a	l	0	a	a	a	l	a
Biodegita	h	l	l	l	l	l	c	l	a	l	l	h	a	l	l	l	a	l	l	h	0	a	a	a	a
Fora	a	l	l	l	l	l	h	l	l	l	h	a	h	h	h	l	a	a	a	a	l	0	h	h	h
Silpo	h	h	l	l	l	l	h	l	h	a	l	h	h	h	a	l	h	a	h	a	l	l	0	h	h
Nizhyn	h	l	l	l	l	h	l	l	h	l	a	a	l	l	l	l	a	l	l	l	l	a	a	0	h
LoSilpo	a	a	h	a	l	l	l	a	h	h	l	h	a	a	l	a	a	l	a	h	a	l	l	a	0

The relevance of brands

- high level of brand relevance;
- average level of brand relevance;
- low level of consumer expectations;
- average level of consumer expectations.

So, taking into account the results of assessing of brands congruence level by the indicators of «relevance of brands» and «consumer expectations», we will build clusters of possible co-branding alliances under the specified conditions (Table 3).

Table following on the next page

Table 3: The clusters of possible co-branding alliances for IBS «Fozzy Group» taking into account their congruence

Level of congruence of brands	The constituents of congruence of brands	Possible alliances of brands IBS «Fozzy Group»
Cluster 1 RhEl	Level of brand relevance <i>high</i> Level of consumer expectations <i>low</i>	trash!+ Extra Protex + Extra Bodegita+ Extra
Cluster 2 RaEl	Level of brand relevance <i>average</i> Level of consumer expectations <i>low</i>	Riki Tiki+ Extra Staromak+ Premia Riki Tiki+ Silpo Voyage Premia + Silpo Voyage Dziao+ Bank «Vostok» Instinct + Silpo Voyage Riki Tiki+ Bodegita
Cluster 3 RhEa	Level of brand relevance <i>high</i> Level of consumer expectations <i>average</i>	Bodegita + Premia Dziao + Silpo Voyage ringo + Bank «Vostok» Lo Silpo + Bank «Vostok» Nizhyn + Select Instinct + Bila Romashka Silpo Voyage + PWC Povna Chasha + Bodegita Varto + U Hrom. Popa Silpo Voyage + U Hrom. Popa Silpo + Zelena kraina Silpo Voyage + Bodegita Silpo Voyage + LoSilpo

Further on the results, obtained after the calculation of economical effect of co-branding, we will conduct an ABC analysis with the purpose to determine the most optimal variants of alliances for co-branding of the IBS "Fozzy Group" (Table 4). It should be noted that the condition for forming a co-branding strategy of integrated business structure is a comparison of the effects of the brands of individual business units and the co-brand. Such analysis depicts that while using this criteria the best co-branding alliances are the following:

- ringo + Bank «Vostok»;
- trash!+ Extra;
- Silpo Voyage + Lo Silpo;
- Riki Tiki+ Bodegita;
- Silpo Voyage + PWC;
- Instinct + Bila Romashka.

However, after evaluating the results of the ABC analysis, the most optimal strategic decisions on the formation of co-branding alliances will be the selection of the three best ones, namely ringo + Bank Vostok; trash! + Extra; Silpo Voyage + LoSilpo, in other words, those alliances, the functioning of which will form 80% of the performance of the entire integrated structure.

Table 4: ABC-analysis of possible co-branding alliances of IBS «Fozzy Group» based on clusters of brand congruency

№	Co-branding alliance	Pbr1	Pbr2	Pbr1+Pbr2	Pco-br	ΔP	Part	Accumulated sum	Group A = 0...80% B = 80...95% C = 95...100%
1	ringo + Bank «Vostok»	2690,43	55850,7	58541,1	65678,4	7137,33	18,02%	18,02%	A
2	LoSilpo + Bank «Vostok»	10961,7	55850,7	66812,41	60567,2	-6245,2	16,62%	34,64%	A
3	Dziao+ Bank «Vostok»	1026,5	55850,7	56877,17	55679,1	-1198,1	15,28%	49,91%	A
4	trash!+ Extra	33487,3	3146,29	36633,58	39769	3135,4	10,91%	60,82%	A
5	Silpo Voyage + LoSilpo	2648,09	10961,7	13609,83	17896,6	4286,73	4,91%	65,73%	A
6	Premia + Silpo Voyage	13712,1	2648,09	16360,22	15789,9	-570,32	4,33%	70,06%	A
7	Bodegita + Premia	2445,29	13712,1	16157,42	15432,8	-724,65	4,23%	74,30%	A
8	Staromak + Premia	1592,8	13712,1	15304,93	14567,3	-737,59	4,00%	78,29%	A
9	Protex + Extra	9209,9	3146,29	12356,19	11468	-888,21	3,15%	81,44%	B
10	Riki Tiki+ Bodegita	5474,36	2445,29	7919,65	10112,5	2192,89	2,77%	84,21%	B
11	Riki Tiki+ Silpo Voyage	5474,36	2648,09	8122,45	8014,25	-108,2	2,20%	86,41%	B
12	Silpo Voyage + PWC	2648,09	2715,71	5363,8	7896,45	2532,65	2,17%	88,58%	B
13	Riki Tiki+ Extra	5474,36	3146,29	8620,65	7890,65	-730	2,16%	90,74%	B
14	Bodegita+ Extra	2445,29	3146,29	5591,58	5246,76	-344,82	1,44%	92,18%	B
15	Silpo Voyage + Bodegita	2648,09	2445,29	5093,38	4988,1	-105,28	1,37%	93,55%	B
16	Silpo + Zelena Kraina	1047,82	2879,33	3927,15	3798,4	-128,75	1,04%	94,59%	B
17	Povna Chasha + Bodegita	1441,38	2445,29	3886,67	3678,5	-208,17	1,01%	95,60%	C
18	Dziao + Silpo Voyage	1026,5	2648,09	3674,59	3610,33	-64,26	0,99%	96,59%	C
19	Silpo Voyage + U Hrom. popa	2648,09	985,7	3633,79	3560,58	-73,21	0,98%	97,57%	C
20	Nizhyn + Select	2199,03	1441,38	3640,41	3456	-184,41	0,95%	98,52%	C
21	Instinct + Silpo Voyage	447,42	2648,09	3095,51	2876,77	-218,74	0,79%	99,31%	C
22	Instinct + Bila Romashka	447,42	660,35	1107,77	1345,78	238,01	0,37%	99,68%	C
23	Varto + U Hrom. popa	355,6	985,7	1341,3	1178,66	-162,64	0,32%	100,00%	C
	Total value				364502				

4. CONCLUSIONS

The current research demonstrates the methodology of optimal structure choice of the co-branding alliance integrated business structure by determining the level of the economic effect of co-branding and assessing the level of congruence of brands and proves that co-branding is a logical extension of the innovative process of expansion and deepening of the integrated marketing activities of the IBS. The emergence of a joint product of business units becomes a determinant of co-branding strategy and leads to the full integration of marketing complexes of integrated structures. For integrated business structures, the creation of a co-brand becomes a logical step forward and an optimal solution in the further joint business of business units.

LITERATURE:

1. Aaker, D. (1991). Managing brand equity. New York: Free Press.
2. Balmer J. M. T. (1995). Corporate branding and connoisseurship. Journal of General Management. 21. 24–46.
3. Carroll, A. B. & A. K. Buchholtz. (2000). Business and Society: Ethics and Stakeholder Management (4th ed.) Cincinnati: South-Western Publishing Co.
4. Chen, K., Newell, S. J., Kou, G. & et al. (2017). Effective strategies for developing meaningful names and associations for co-branded products in new and emerging markets. Journal of brand management, 24(4), pp. 362-374/

5. Decker, C. & Baade, A. (2016). Consumer perceptions of co-branding alliances: Organizational dissimilarity signals and brand fit. *Journal of brand management*, 23(6), pp. 648-665.
6. Fleck, N.D., Michel, G. & Gatignon, H. (2012). The Dual Process of Co-branded New Products: Why Fit is Not All That Matters. Working paper, INSEAD, France, 42 p.
7. Hair, J. F., Jr., Anderson, R. E., Thatam, R. L., & Black, W. C. (1998). *Multivariate Data Analysis* (5th ed). Prentice-Hall, International, Inc.
8. Hu, J., Song, M. & Yu, X. (2017). Fuzzy Cognition on Factors Influencing the Co-Branding in Technical Standards Alliance - From Member Selection Perspective. *Journal of advanced computational intelligence and intelligent informatics*, 21(6), pp. 1065-1072.
9. Itami, H. & Roehl, H. (1987). *Mobilizing Invisible Assets*. Harvard University Press.
10. Keller, K. L. (2003). *Strategic brand management*. 2nd edition Englewood Cliff, NJ:Prentice Hall.
11. Lee, Ch. & Decker, R. (2016). Co-branding partner selection: The importance of belief revision. *Journal of business economics and management*, 17 (4). pp. 546-563.
12. Lipsey, M.W. & Wilson, D.B. (2001). *Practical Meta-Analysis*. Sage Publications: Thousand Oaks, CA, USA. 49.
13. Praude, V. & Shalkovska E. (2010). Synergistic effect in marketing system. *Scientific inquiry*, 11 (1), pp. 25–34.
14. Singh J. J., Iglesias O. & Batista-Foguet J. M. (2012). Does having an ethical brand matter? The influence of consumer perceived ethicality on trust, affect and loyalty. *Journal of Business Ethics*. 111. 541–549.
15. Urde, M., Baumgarth C., & Merrilees B. (2013). Brand orientation and market orientation – From alternatives to synergy. *Journal of Business Research*. 66.
16. Voss, K. E. & Mohan, M. (2016). Corporate brand effects in brand alliances *Journal of business research*, 69 (10), pp. 4177-4184.

FACTORS OF THE COUNTRY'S ENERGY SECURITY

Svetlana Rakyt'ska

*Odessa State Academy of Civil Engineering and Architecture, Ukraine
svetlana.rakitska@gmail.com*

Oksana Zhus

*Odessa State Academy of Civil Engineering and Architecture, Ukraine
yusenok@ukr.net*

Vladimir Mishchenko

*Odessa State Academy of Civil Engineering and Architecture, Ukraine
prostoelmin121995@gmail.com*

ABSTRACT

The development of the world economy depends on the level of provision of energy resources. Prospects for the growth of the country's economy are due to the success of solving energy conservation problems. The priority of such policy in Ukraine is caused by the shortage of own fuel and energy resources, dependence on the countries-exporters of gas and oil, and also the global environmental situation. It is necessary to activate internal opportunities of energy conversation. Low energy efficiency was a characteristic feature of the economy of the USSR, and from the moment of independence of Ukraine became the cause of the crisis. The technologically obsolete structure of the national economy and the high energy intensity of products limit its competitiveness in foreign and domestic markets. The crisis in the energy sector led to an increase in energy tariffs, social tensions in society increased. Now the population and all spheres of business depend on the state policy. Ukraine can activate the energy conversation potential and will become an attractive sales market of innovative energy-saving technologies and equipment. There are a number of factors that affect the development of energy efficiency: market, investment, information, technical and institutional. Each of them may have a positive or negative impact on the overall situation. Therefore, the priority of the energy conversation strategy in Ukraine should be reinforced by effective interaction of government, business, population and scientific organizations. An important condition for the development of these relations is the observance of the interests of all participants.

Keywords: *energy conversation, fuel and energy resources, innovative energy-saving technologies*

1. INTRODUCTION

The current social and economic situation in Ukraine and its development prospects largely depend on the solution of energy conservation problems. The need to introduce a priority energy conservation policy is primarily related to the deficit of own fuel and energy resources. The economic crisis significantly aggravated the issue of providing energy resources to the national economy. Insufficient volume of own energy carriers requires their import. However, in the conditions of a reduction in the world reserves of these resources and the growth of prices for them, the solution of energy problems only through imports is not enough. Therefore, the issue of ensuring energy efficiency and energy conservation in all spheres of the national economy is topical and determines the energy security of the country as a whole. The purpose of the work is to analyze the theoretical and methodological provisions, as well as the substantiation of practical recommendations for improving the implementation of energy conservation measures in the economy of Ukraine. To achieve the goal, the following tasks have been set: to analyze the current state of the Ukrainian energy market and the features of its functioning; to

investigate the level of energy efficiency and energy conservation potential in Ukraine; consider the legislative and regulatory framework in the field of energy conservation; to analyze programs for supporting energy conservation in the housing and communal services at the state and regional levels; justify the economic feasibility of energy conservation measures in the residential sector; suggest ways to improve the relationship of energy conservation in Ukraine.

2. THE STATE OF ENERGY SUPPLY AND ENERGY CONSERVATION IN UKRAINE

One of the most important issues that determine the possibility of sustainable development of society is the achievement of energy security. Theoretical and applied scientific research on the development and implementation of energy conservation measures began to be carried out for a long time ago - at the beginning of the 20th century. The developed countries of the world, first of all, the EU countries, have already received significant success in solving energy efficiency problems and continue to search for new sources of energy supply. The economical expenditure of energy resources and increasing the efficiency of their use at all stages of production and consumption is the most important task of all subjects of the market economy. Much attention should be paid to the development of modern technologies and the implementation of organizational, technical and economic measures to increase the energy efficiency of production. Also, a significant role belongs to investments in the implementation of energy conservation technologies that ensure the competitiveness of enterprises and create the basis for their strategic development. According to the State Statistics Service of Ukraine, in the energy balance of the country for 2016, the total primary energy supply amounted to 91.7 million tons of oil equivalent, which is 1.7% more than in 2015 (State Statistics Service of Ukraine, 2018). The structure of total primary energy supply was characterized by a high proportion of natural gas (27.9%, 26 million toe). The share of nuclear power was 23.2% (23 million toe) of coal - 32.4% (27 million toe) of crude oil and petroleum products - 12.2% (10,500,000 toe.) biomass (biomass, fuel and waste) - 2.2% (2 million toe), hydroelectric power station - 1.1% (1 million toe) of thermal energy (thermal energy of the environment and waste resources of technogenic origin) - 0.6% (0500000 toe) and wind power plant together with solar power plant - 0.1% (0100000 toe). The total share of all renewable energy sources was 3600000 toe, or only 4%. Analyzing the state of the energy market, we can identify certain features of its functioning, in particular: The energy market in Ukraine is largely monopolized, since the share of "pure monopoly" markets in the volumes of sales of the fuel and energy complex is 17.2%, with signs of dominance - 64.5%, rigid oligopoly - 0.2%, with competitive structure - 18.1% (Lavrenenko, 2015). The structure of the energy market is dominated by segments of traditional energy resources - oil and gas, the state of development of which is characterized by a significant gap between supply and demand. The problem has worsened in recent years, because due to the occupation of Crimea, Ukraine has no control over the state company 'Chernomornaftogaz' and over the Black Sea shelf, where two new floating installations operated. The other part of the productive capacity is located in the occupied territory of the Donbas, here the losses amounted to a less significant amount - 50 million cubic meters (Koval H., 2015). Between the volumes of domestic production and consumption of this resource, there is a significant imbalance, since only 58% of the needs are covered by domestic production, the other 42% are satisfied through import. However, if in 2015 Ukraine imported 4100000000 cubic meters of gas, 56% of which have a European origin, then in 2016-2017 the supply of imported gas to Ukraine was carried out exclusively from the European gas market. Compared to 2016, gas imports has increased by 27% - from 11.1 billion cubic meters to 14.1 billion cubic meters (Naftogaz Group's website, 2018). A complex situation has developed in the oil segment of the energy market. By the end of 2016, Ukraine reduced oil production with gas condensate by 7.5% compared to 2015 - up to 2 million 236.6 thousand tons. In January-December 2017,

oil production with gas condensate amounted to 1 million 921.3 thousand tons, which is 95.6% of the same period in 2016 (Statistics Service of Ministry of Energy and Coal Industry of Ukraine, 2018). And when comparing domestic production with consumption, there is an obvious imbalance and the need for imports. Since 2014, due to military operations in the Donbas, Ukraine has significantly reduced the extraction of coal. This trend continued in the past year. So, in January-November 2017, compared to the corresponding period of 2016, coal production decreased by 13.6% - to 31 million 964.1 thousand tons. However, demand is 22 million 465.1 thousand tons and is fully satisfied at the expense of own resources (Statistics Service of Ministry of Energy and Coal Industry of Ukraine, 2018). Electricity production in the unified energy system of Ukraine in 2016 decreased by 1.8% compared to the same period in 2015 - up to 154,817,400,000 kWh. Note that the needs are satisfied, but certain rules were introduced in order to reduce consumption. A significant problem is the loss of energy resources, which are caused by unsatisfactory technical condition of the objects of the energy market. The degree of depreciation of fixed assets of the fuel and energy sector reaches 60.7%. The magnitude of electricity losses in public networks in 2015 exceeds 12% of total electricity supply to the grid, the share of losses in heating systems exceeds 20% (Energy Strategy of Ukraine for the period up to 2035, 2017). In 2016, the volume of emissions of harmful substances into the air from stationary sources of pollution increased by 7.7% compared to 2015 and reached almost 3.1 million tons, which is 5,339 kg per 1 sq. km. In addition, from stationary sources of pollution to the atmosphere, 150.5 million tons (8.4% more compared to 2015) of carbon dioxide - the main greenhouse gas, which affects climate change (State Statistics Service of Ukraine, 2018). High energy intensity of GDP, which in 2015 amounted to 0.28 tons of oil equivalent / thous.doll. USA Global Energy Statistical Yearbook 2016, which, in conditions of a lack of own energy resources, significantly limits the competitiveness of the domestic product in the domestic and foreign markets. Low energy efficiency has strengthened the crisis phenomena in the economy of our state, which have acquired manifestations since independence. In the first half of the 1990s, in the cost structure for the manufacture of industrial products, the cost component of energy resources has increased almost threefold, reaching 42% of the total material costs of production. However, since 2002, the rate of decline in the energy intensity of GDP has slowed due to the fact that in the most energy-intensive sectors of the economy-metallurgical, machine-building, chemical and petrochemical, and in housing and communal services, the dynamics of reducing the energy intensity of gross value added have undergone negative changes caused by an unacceptably high degree of physical depreciation of fixed assets (65-70%), and a corresponding increase in the specific costs of fuel and energy resources for a number of important types of products. According to the Energy Trilemma Index, calculated by World Energy Council (WEC), Ukraine in 2015 took the 110th place among 130 countries of the world. The WEC index is assigned on the basis of a comparative analysis of the energy situation in the country and is marked by three factors: Energy Security, Energy Equity and Environmental Sustainability. Depending on the success in each direction, the country is given a rating from A to D. Rating of Ukraine – BCD (World Energy Trilemma Index, 2015). However, as early as in 2016, Ukraine ranked 63rd by the mentioned index World Energy Trilemma Index, 2016), and in 2017 - 48th place, with the rating of ABD (World Energy Trilemma Index, 2016), which indicates certain positive changes in the energy sphere of the state. If energy conservation is an element of economic and ecological expediency for the industrialized countries, then for Ukraine it is a question of survival in market conditions and entry into European and world markets. Problems of achieving a balanced effective demand in the domestic and foreign markets are subject to decision, as well as diversification of imports of fuel and energy resources. The crisis in the energy sector is one of the reasons for the phased increase in tariffs for energy resources. Changes in the tariff policy lead to certain difficulties for most economic entities associated with payment for electricity, gas, heat, water etc.

At the moment, the population and all spheres of business have become to a certain extent dependent on state policy and the situation in the country. Therefore, the primary task for business structures and housing and communal services is to reduce the cost of energy used to ensure their activities. Low energy efficiency of GDP in Ukraine is a consequence of a number of factors, primarily a technologically obsolete structure of the national economy and a significant lag in most industries from the scientific and technological level of advanced countries objectively limits the competitiveness of national production. And these factors should play a leading role in the implementation of the energy efficiency strategy. Confirmation of this thesis is the conclusions of experts, according to which the energy conservation potential in Ukraine consists of the energy conservation potential due to the technical (technological) component and the energy conservation potential due to the structural component. According to expert estimates, the total energy saving potential due to technical (technological) and structural factors in the economy of Ukraine in accordance with the basic scenario of economic development and its spheres is 318360000. tons of reference fuel (Denysiuk S., 2016). However, in order for this indicator to be achieved in the forecast period, it is necessary to implement the relevant measures of the state policy in the field of energy conservation. This allows us to state that the main requirement for ensuring the effective functioning of the domestic energy market is energy saving, which should cover all segments of this market. Energy saving will allow to rationalize the expenditure of energy resources in the process of GDP production and increase the competitiveness of the energy market; to provide economy of financial resources of households, consuming energy resources; to reduce anthropogenic load on the environment.

3. DEVELOPMENT OF ENERGY EFFICIENCY IN UKRAINE

The complexity, multidimensionality and topicality of energy conservation problems make it necessary to introduce energy management at all levels of the economic system. By "energy conservation management" is meant a management system that is aimed at ensuring the rational use of fuel and energy resources by consumers (State standard of Ukraine 4472-2005, 2006). State Standard of Ukraine 4472-2005 "Systems of energy management. General requirements" defines energy management as "activities aimed at ensuring the rational use of fuel and energy resources and is based on obtaining energy-technological information through accounting, conducting a typical energy-technological measurement and verification, analyzing the efficiency of using fuel and energy resources and introducing energy-saving ones". The development of energy efficiency in a single country is influenced by various factors, shown in Figure 1.

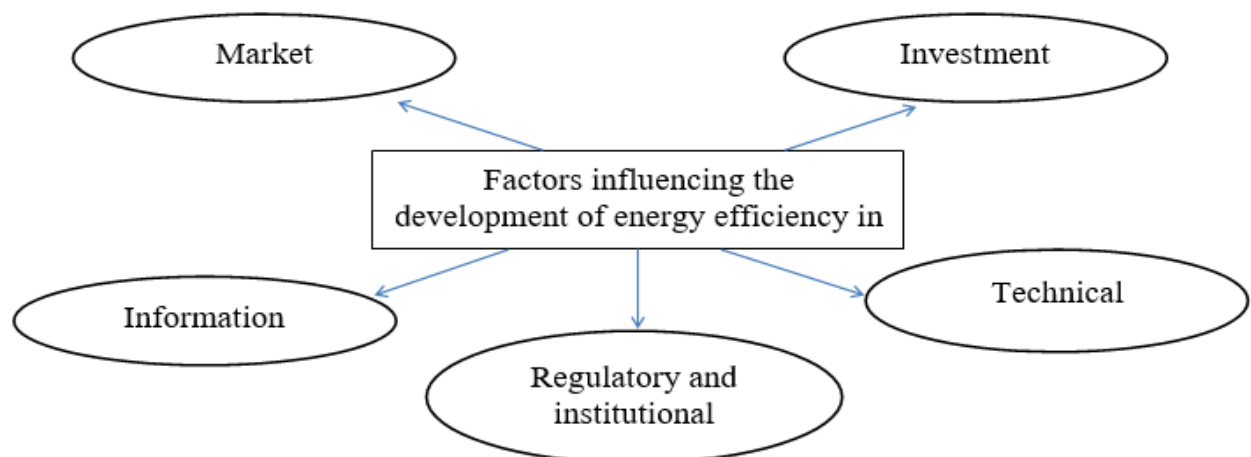

Figure 1: Factors influencing the development of energy efficiency in the economy

As Figure 1 shows, one of the groups of factors is the market. Their influence is caused by problems due to the conflict of interests of market actors in the process of implementation of energy saving projects, price disparities in the market, which make it difficult for consumers to comprehensively and thoroughly evaluate energy efficiency. The effect of investment factors arises from the perception of investments in energy efficiency as complex and risky, with high costs and delayed benefits in time. The lack of sufficient information and understanding on the part of consumers to make a decision about the rationality of implementing energy-saving measures makes it very difficult to achieve energy efficiency. Conversely, wide awareness of energy saving opportunities can significantly accelerate this process. The impact of technical factors is determined by the availability or lack of available energy efficiency technologies that are acceptable with local requirements; level of scientific and technical capacity to identify, develop, implement and support investments in energy efficiency. The positive influence of regulatory factors is formed if the tariff policy encourages consumers to invest in energy saving, and the incentive structure, in turn, encourages energy companies to invest in economically beneficial energy efficiency, reduce energy losses at all stages of its production and delivery to the end customer. The absence of well thought out regulatory tools of a systemic nature makes it impossible to achieve the desired result. Regulatory factors are closely related to institutional factors that acquire manifestations through the formation of a certain institutional environment, the level of development of which determines the quality of management of energy efficiency processes in the country. Thus, the negative or positive impact of these factors in a particular country is determined by the existing socio-economic, political, market situation and can be adjusted by means of state regulation. The intensification of the state policy on energy efficiency in Ukraine is caused by following circumstances (Figure 2).

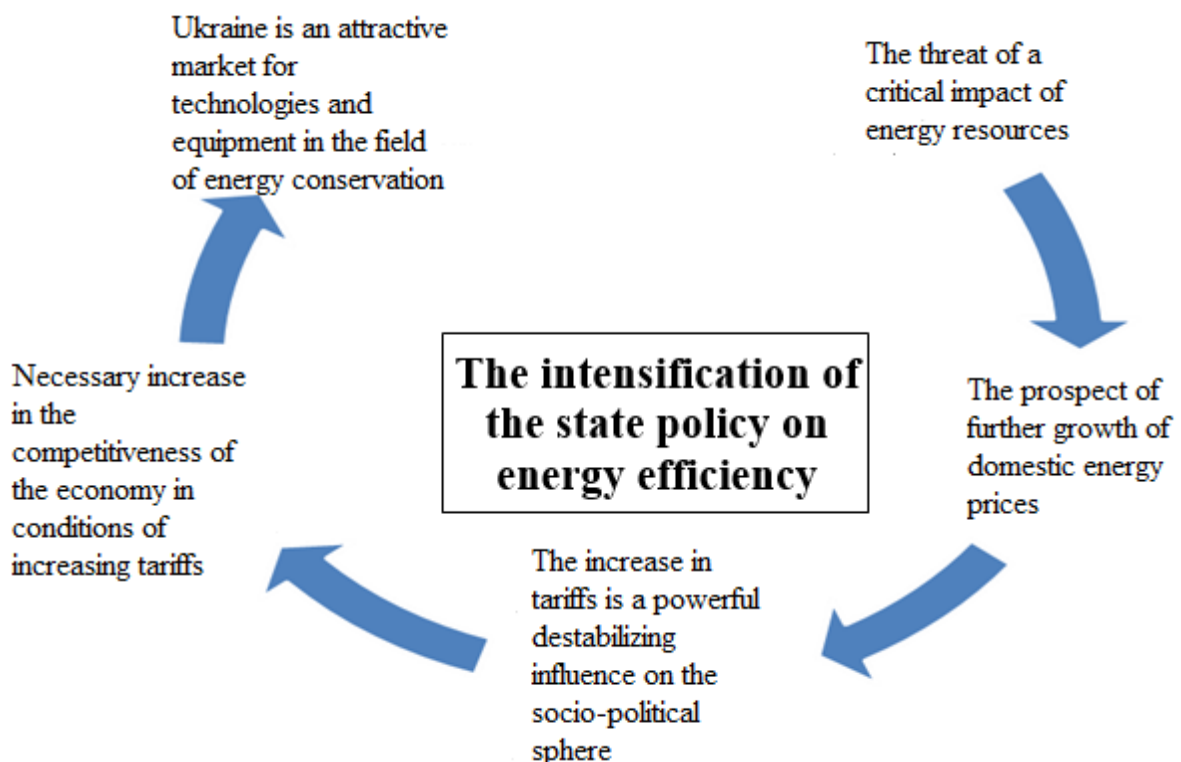

Figure 2: Factors of activation of the state course on energy efficiency in Ukraine

With the aim of regulating energy efficiency and energy efficiency in Ukraine, a number of documents have been adopted at the state and regional levels - the Laws of Ukraine and regulations, which identify the optimal ways to solve the problem of increasing energy

efficiency in Ukraine through investment and innovation development. The main ones are the Law of Ukraine "On Energy Conservation", the Law of Ukraine "On Electric Power Industry", the Law of Ukraine "On Alternative Energy Sources", the Law of Ukraine "On Heat Supply", the Law of Ukraine "On energy efficiency of buildings ", etc. It is approved the "Energy Strategy of Ukraine for the period until 2035". For Ukraine, energy efficiency is the most important resource and guarantor of the formation of the necessary potential for the further development of the state and society. "Energy Strategy of Ukraine for the period until 2035" defines the main directions for increasing the energy efficiency of the Ukrainian economy, which are shown (Energy Strategy of Ukraine for the period until 2035, 2017):

- raising of the consciousness of energy saving among citizens, encouragement of the use of household appliances and lighting with high energy efficiency indicators;
- reduction of energy consumption of households, commercial and municipal sectors for heating by increasing the energy efficiency of residential and public buildings, as well as improving the energy efficiency of heating appliances;
- reduction of energy costs in the transportation and distribution systems of electric and thermal energy through technical, technological modernization and conceptual revision of energy supply schemes, taking into account the achievements in the field of decentralized energy supply, including through the use of RES and energy management;
- assessment of the potential for optimizing the central heating system by switching to individual heating in regions and facilities where this is economically feasible;
- completeness and transparency of accounting for all forms of energy (electricity and heat, natural gas);
- increase of energy efficiency in the sector of production and transformation of energy, first of all in heat and power engineering and centralized heat supply through optimization of capacity utilization, technical and technological modernization;
- implementation of the energy management system at the level of the state, cities, budget and administrative buildings and enterprises.

A significant role in the implementation of the state energy saving strategy is played by the implementation of appropriate measures in the domestic sector, which is primarily caused by its share in energy costs: the largest final consumers of energy in 2016 were the domestic sector and industry, accounting for 34% and 29% respectively (State Statistics Service of Ukraine, 2018). Such activities as housing and communal services and the construction of residential, public buildings, as well as the construction materials industry are characterized by a high level of energy intensity. Meanwhile, buildings are a priority for increasing energy efficiency, this sector accounts for about 40% of total energy consumption. Among the main directions of implementing the policy of increasing the energy efficiency of buildings can be identified:

- development and implementation of building codes and regulations for new buildings;
- wide use of new (renewable) energy sources for energy supply and bringing it to zero energy consumption level;
- development and implementation of a set of measures (regulatory, legislative, economic, information) to improve the energy efficiency of existing buildings;
- development and effective implementation of the construction certification system.

The perspective direction of increasing energy efficiency is thermal insulation and thermal upgrading of buildings. To date, only 25% of the housing stock in Ukraine is responsible for the consumption of energy resources to state construction standards, other buildings, most of which are residential, require the introduction of energy-efficient measures. This is caused by physical aging of buildings, lack of timely repair and modernization works, lack of full control over the energy consumption level of existing buildings and those that are only being built.

Considering the total number of houses and structures and the specific energy consumption for their heat, it is necessary to pay great attention to thermal insulation and energy saving. Since October 2014, the government program for "warm credits", developed and implemented by the State Agency for Energy Efficiency and Energy Conservation of Ukraine, has been in operation for the population and Association of Owners of Apartment House, which was renewed in 2017-2018. Also, local programs of cheapening "warm" credits continued to operate, for which additional compensation (from local budgets) of the principal debt or interest for "warm" credits is provided. Currently, there are 206 such programs of different levels in all regions of Ukraine. Due to the simultaneous implementation of the city and state programs, the prerequisites for the emergence of a corresponding synergetic effect towards the implementation of energy-efficient housing modernization are provided. However, at present the use of heat energy in the housing stock of the city is irrational, there are unproductive costs for its production, which leads to the need to introduce appropriate savings measures, about 70% of the housing stock needs a complete thermo-modernization. An important condition for the activation of energy-saving processes is to ensure the interest of construction companies in the implementation of energy-saving measures, the implementation of after-sales service. Contracts with Association of Owners of Apartment House for provision of maintenance and home maintenance services (video surveillance, repair of plumbing and electrical equipment, sidewalks, etc.) will provide an additional source of revenue from the sale of products and services. Aspiration to energy efficiency activates the mechanism of introduction of the newest technologies, attraction of the scientific organizations in energy saving processes. This can be achieved only if the interests of all parties are observed, as evidenced by calculations of the commercial efficiency of the project.

4. CONCLUSION

Rational use of energy resources - one of the basic indicators, illustrates the economic, social and scientific development of the country. Now the energy intensity indicators of Ukraine's GDP are several times higher than in Europe. The limited nature of natural resources in Ukraine, determines the index of import dependence at the level of 51.6%, which represents a risk for the energy security of the country. Preservation of existing trends can bring to critical changes in the economy, further lowering the standard of living of the population, will not allow to overcome the technological backwardness of the country from the developed countries of the world and to prevent Ukrainian goods from being competitive on the international market. Energy conservation is an important energy potential of the state. Ensuring implementation of energy saving measures is one of the main tasks of the modern development of Ukraine. A lot of attention is paid to this issue in the program documents related to energy efficiency and energy saving problems. To increase the attractiveness of the implementation of activities provided for by the regulatory framework, it is necessary to ensure the economic rationality of rational use of energy resources for all participants in the energy consumption process. For co-owners of multistoried houses, a special loan program for the acquisition of modern equipment and insulation of the house has been developed. Provision is made for a part of the loan taken for energy-efficient equipment ("negative" boilers) at a rate of 20% and materials at a rate of 30%. To persons who are assigned a subsidy, compensation is set at 70%. The mechanism of state support for Association of Owners of Apartment House and Housing and Utilities Sector provides for the reimbursement of 40% of loans for the purchase of energy efficient equipment and materials. In many regions of Ukraine, regional programs are being developed and implemented that provide for compensation of interest on loans from local budgets. The analysis of the economic feasibility of implementing energy saving measures confirms their effectiveness. However, the existing mechanism can be improved by effective interaction of government, business, population and scientific organizations.

An important condition for the development of these relations is the observance of the interests of all participants and the confirmation of the proposed measures by calculating the commercial effect.

LITERATURE:

1. Denysiuk S., Kotsar O., Chernetska Y.. (2016). Energy efficiency of Ukraine. Best project ideas / Professionalization and Stabilization of the Ukrainian Energy Management. Kiev: National Technical University of Ukraine "Igor Sikorsky Kyiv Polytechnic Institute", available at: <http://io.iee.kpi.ua/projects/professionalization-and-stabilization-ukrainian-energy-management> (Accessed 08.04.2018)
2. Energy Strategy of Ukraine for the period up to 2035 "Safety, Energy Efficiency, Competitiveness" (Approved by the Decree of the Cabinet of Ministers of Ukraine dated August 18, 2017 No. 605-p) available at: <http://zakon3.rada.gov.ua/laws/show/605-2017-%D1%8> (Accessed 11.04.2018)
3. Global Energy Statistical Yearbook 2016 / Enerdata, available at: <https://yearbook.enerdata.net/> (Accessed 08.04.2018)
4. In 2017, Ukraine bought 14.1 billion cubic meters. m of gas from the European direction Retrieved / Naftogaz Group's website (31.01.2018) available at: <http://www.naftogaz.com/www/3/nakweb.nsf/0/898ABF94AE07BADAC2258226005ABA88?OpenDocument&year=2018&month=01&nt=%D0%9D%D0%BE%D0%B2%D0%B8%D0%BD%D0%B8&> (Accessed 28.03.2018)
5. Koval H. (03.02.2015) Oil and gas extraction in 2014. Review. Ukrainska pravda: Economic truth. available at: <http://www.epravda.com.ua/columns/2015/02/3/525569/> (Accessed 28.03.2018)
6. Lavrenenko, V.V. (2015). Financial-credit provision of energy saving in Ukraine. Youth Economic Digest, 2015, 1. – p. 118–122. — available at: <http://ir.kneu.edu.ua:8080/handle/2010/10511> (Accessed 06.03.2018)
7. Law of Ukraine "On Alternative Energy Sources" 20.02.2003 № 555-IV (2017) available at: <http://zakon2.rada.gov.ua/laws/show/555-15> (Accessed 08.03.2018)
8. Law of Ukraine "On Electricity": 16.10.1997 № 575/97-BP (2017) available at: <http://zakon2.rada.gov.ua/laws/show/74/94-BP> (Accessed 11.04.2018)
9. Law of Ukraine "On Energy Efficiency of Buildings" (2017) available at: <http://zakon2.rada.gov.ua/laws/show/2118-19> (Accessed 11.04.2018)
10. Law of Ukraine "On Energy Saving": 01.07.1994 p. №74/94-BP (2013) available at: <http://zakon2.rada.gov.ua/laws/show/74/94-BP> (Accessed 11.04.2018)
11. Law of Ukraine "On Heat Supply" 02.06.2005 № 2633-IV (2017) available at: <http://zakon2.rada.gov.ua/laws/show/2633-15> (Accessed 11.04.2018)
12. State Standard of Ukraine 4472-2005. Energy management systems. General requirements:– K.: Derzhspozhyvstandart of Ukraine, 2006. – p.22.
13. State Statistics Service of Ukraine (2018), Economic statistics, available at: <http://www.ukrstat.gov.ua> (Accessed 10 April 2018) (Accessed 18.03.2018)
14. Statistics Service of Ministry of Energy and Coal Industry of Ukraine (2018) available at: http://mpe.kmu.gov.ua/minugol/control/publish/newscategory?cat_id=35081 (Accessed 18.03.2018)

DEVELOPMENT OF TRADE RELATIONS BETWEEN CENTRAL EUROPE AND SCANDINAVIA AS A DETERMINANT CREATING POLISH FERRY SHIPPING MARKET

Ilona Urbanyi-Popiolek

*Gdynia Maritime University, Poland
i.urbanyi@wpit.am.gdynia.pl*

Tomasz Studzieniecki

*Gdynia Maritime University, Poland
tomaszstudzieniecki@wp.pl*

ABSTRACT

Ferry shipping is well developed in the Baltic Sea Region. Polish ferry market is a prime segment of ferry industry in South Baltic. Services from Polish ports to Sweden determine the carriage of units and wheeled cargo as well as transport of passengers between Continent and Scandinavia. Since Poland and other states have acceded to the European Union, growing foreign exchange between Continental and Scandinavian countries is visible and Polish ferry market has been affected by increasing demand for transport. These services as the only ones in the Baltic Sea have not recorded decline in turnover since 2008. Polish ferry terminals located in Swinoujscie, Gdynia and Gdansk are pointed as transport nodes in Baltic – Adriatic Corridor. Ferry routes from mentioned ports constitute the shortest connections for cargo transported from Central European countries to Scandinavia. These two factors determine the add value and competitiveness of Polish ferry market. The aim of the article is to analyse the trend in foreign trade among the above countries, the market development as well as study the interrelationship between the trade volumes and ferry turnover. The research hypothesis is: the increase in trade between Central Europe and Scandinavia is the prime factor developing the demand for ferry services in Polish shipping market. Detailed research hypothesis is that: the group of factors affecting Polish ferry market are both opportunities and threats for development of ferry traffic. In order to verify the hypothesis, the article is focusing on following aspects: international trade volumes and trends between Scandinavia and Central Europe, potential of Polish ferry market in context of market requirements.

Keywords: *Baltic Sea Region, cargo volumes, Central Europe, ferry shipping, , international trade, Polish ferry market*

1. INTRODUCTION

In Baltic Sea Region the strong economic relations between the countries are observed. The cooperation concerns many areas comprising trade exchange, foreign direct investments (FDI), tourism, services. Most Baltic and Central Europe states trade with neighbours and countries located relatively close. The mutual connections between Nordic countries, as well as between the latter and Central Europe are prime factor of the development of foreign trade in the region. Commercial relations and the size of the exchange affect cargo flows between continental Europe and Scandinavia. The demand for transportation and patterns of supply chains from Central Europe to Scandinavian and vice versa are complementary to mutual trade turnover. Grzelakowski emphasises that development of international trade and the demand for transport service are determined by a number of factors, as macroeconomic factors of the economic growth of the Baltic Sea Region and Central and Eastern, expressed in terms of synthetic growth of GDP in these countries, the increase in production and consumption, the dynamics of trade development and its commodity and geographical structure, as well as transport conditions

determining the ability to handle trade flows between the countries of the region and transit cargo (Grzelakowski, 2010, p. 74).

2. LITERATURE REVIEW AND METHODOLOGY

Problems concerning Baltic Sea Region are considered in numerous studies. The scope of research is wide and includes such areas as economic, cultural and social relations between the Baltic states, transport in the region, tourism, sustainability development and environmental aspects. Baltic states demonstrate strong economic relations. The authors emphasise the close cooperation in international exchange in the region (i.e. Mezhevich, Kretinin, Fedorov, 2016, pp. 11-21, Laaser, Schrader, 2017, pp. 111-130). International trade and FDI are recognized as factors creating impact on regional economy (i.e. Fedyunina, 2016, pp. 93-112, Nakamura, Olsson, Lonnborg, 2012, pp. 89-108, Kotilainen, Nikula, 2010, pp. 5-43, Kosov, Gribanova, 2016, pp. 33-44, Purju, Branten, 2013, pp. 4-15). Pass and Tafenau imply that international trade relations provide good preconditions and challenges for continuing integration creating also spatial spillover effects. In addition to several other factors, the intensity of international trade flows is significantly influenced by transportation costs and consequently by distance (Pass, Tafenau, 2005, pp. 1-2). In the other hand sustainable development and the mobility is stressed as growth of trade turnover impact the demand for transport and affect the port cities (Studzieniecki, Przybyłowski, 2017, pp. 495-505). Commercial relations and size of the international exchange affect cargo flows in the region. Goods between Nordic and continental countries are carried primary by vessels. Part of German and other West European countries intercourse with Scandinavia are transported by road via Denmark and fixed links in Great Belt and Oresund. However maritime transport carries the majority of mutual turnover in North – South axis. Serry states that ro-ro transport, handled by ferries and ro-ro cargo ships, typically represent Baltic internal transport which covers up to 80 per cent of total (Serry, 2014, pp. 1-20). Ferry shipping is well developed in the Baltic Sea Region. In studies and in practice there is not an uniform definition of ferry as the nature of this kind of maritime transport is specific. Kotowska describes ferry shipping as mode of maritime transport where two segments: passengers traffic and cargo transportation are characteristic (Kotowska, 2014, pp. 94-95). Stapford notes that ferries transport people, goods and vehicles over short distances by sea (Stapford, 2009, p.501). Most authors however focus either on cargo or passenger segment. Musso, Paixao and Lynce define ferry shipping as a segment of short sea shipping and emphasise that these connections are an important element of road – sea transport system to and from continental Europe (Musso, Paixao, Lynce, 2010, p.401). Paixao and Marlow highlight the importance of ferry services in multimodal transport chains (Paixao, Marlow, 2009, pp.1-19). The article focuses on commercial intercourse between countries of Central Europe and Scandinavia being the natural hinterland for Polish ferry market. Finland is outside the scope of the study as no ferry connection from Poland to Finish port exists and cargo flows to Finland do not affect the Polish ferry market. The research hypothesis is: the increase in trade between Central Europe and Scandinavia is the prime factor developing the demand for ferry services in Polish shipping market. Detailed research hypothesis is that: the group of factors affecting Polish ferry market are both opportunities and threats for development of ferry traffic. The research methods are the analysis of original data of trade turnover and data published by ferry operators as well as in-depth interviews conducted with CEOs of Polish ferry operators.

3. FACTORS DETERMINING THE FERRY MARKET – THEORETICAL MODEL

Several important factors determining the ferry market can be distinguished. The prime is the level and structure of foreign exchange between the states when the delivery can be made using the sea transport.

Ferries carry general cargo transported in units as lorries, semi-trailers, rarely in containers on trailers and rail wagons. The commercial intercourse is regarded as the most important driver creating the demand for cargo transportation (see Figure 1). The next is port infrastructure. The technology and organization of ferry shipping require dedicated terminals with efficient handling. The terminals are equipped with facilities for ro-ro technology – berths with ramps and internal roads for cargo drive in and drive out the ship. The ferry services are based on schedules and the time for handling operations is limited usually to 2-4 hours. In this duration the vessels have to be discharged and loaded again. Promptness is required by trades, hauliers, forwarders and ferry carriers, as delays create congestions in terminals and affects the logistics chains. Terminals services comprises also storage as well as administration and customs procedures. The accessibility to ferry terminals is another factor. The connections with the hinterland comprises road and rail infrastructure and contribute to the demand for ferry operations. Sufficient land connections constitute opportunity for ferry operation as easy access to ferry terminals is one of the most important factors of choice the given ferry link. The demand comprises carriers operating ferry links with suitable number of ships and given frequency. The available capacity is calculated by the length of load line and number of sailings. The access to transport service is prime strength of ferry route and indicates the quality of the service, as well as its competitiveness.

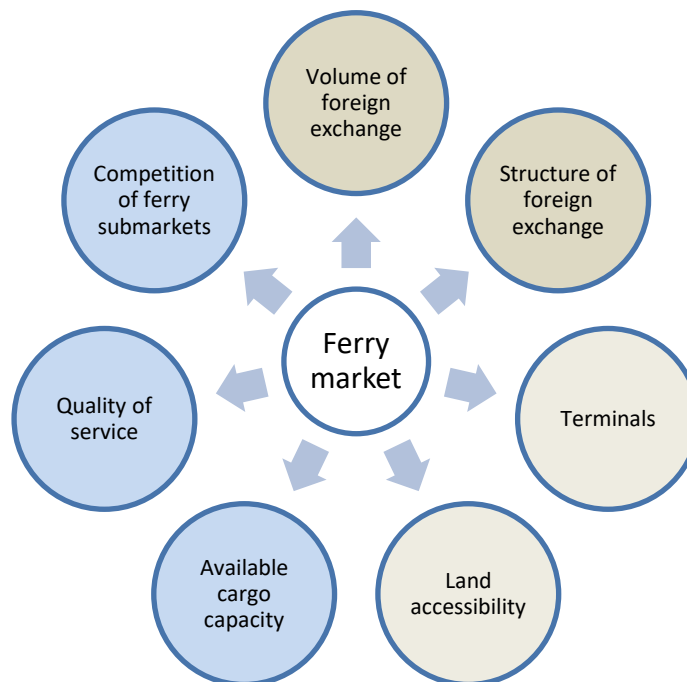

Figure 1: Prime determinants for ferry market (own elaboration)

4. ANALYSIS OF COMMERCIAL INTERCOURSE BETWEEN CENTRAL EUROPE AND SCANDINAVIA

Central European states and Scandinavia display strong commercial relations. The level of exchange developed since these countries have acceded to the European Union. However the mutual turnover demonstrates the difference in value and volume in exports to and imports from individual states. The highest trading volume is observed with Sweden being the leading Scandinavian partner for Central European countries. Among analysed states, Poland has become a leading trading partner for Sweden. (Figure 2 and 3). In 2017 the Polish exports amounted to 5,6 billion EUR whereas imports from Sweden totalled to 4,67 billion EURO (respectively 2,79 million tons in export and 2,18 million tons in import). In Polish trade with Sweden, electromechanical industry products lead (43.3% of exports and 33% of imports).

A significant share is also represented by the chemical industry and metallurgy products. Another important group comprises wooden products, furniture, agricultural commodities and foodstuffs. The average value of 1 metric ton amounted to 2000 and 2140 EUR in exports and imports respectively. Trade exchange of other Central European countries with Sweden is much lower (Figure 2 and 3). The next trading partners is Czech Republic with turnover of 2,5 billion EUR in exports to and 1,2 billion EUR in imports from Sweden. The reached trade figures are half of Polish exchange.

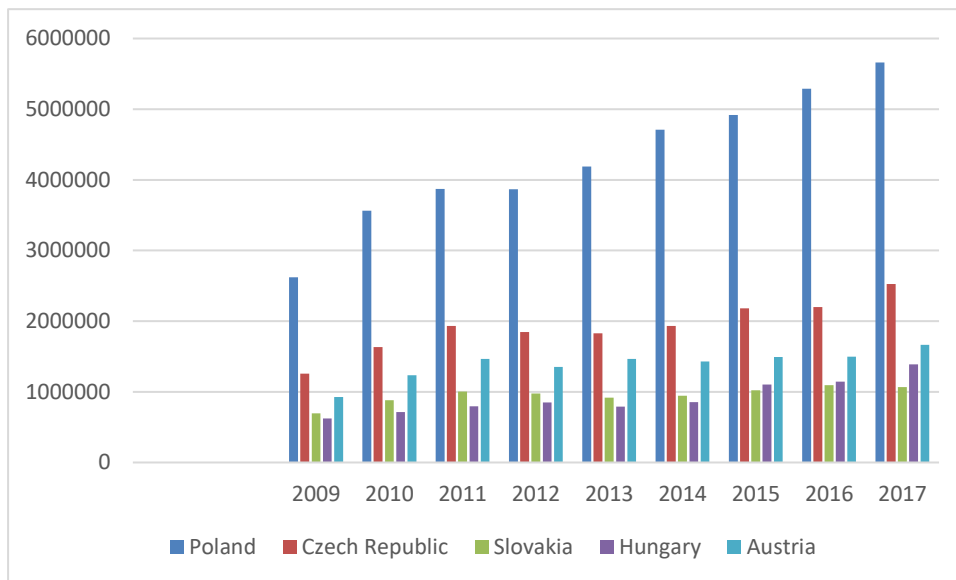

Figure 2: Export development from selected Central European countries to Sweden EUR thousand (own elaboration based on Eurostat database)

Hungary's trade amounted to 1,38 billion EUR and 0,7 billion EUR in exports and imports respectively. Austria located further west to Central Europe has recorded higher exchange. The country is considered due to cargo flows between Scandinavia and the Continent. The commodity structure of mutual intercourse analysed countries is similar to Polish trade.

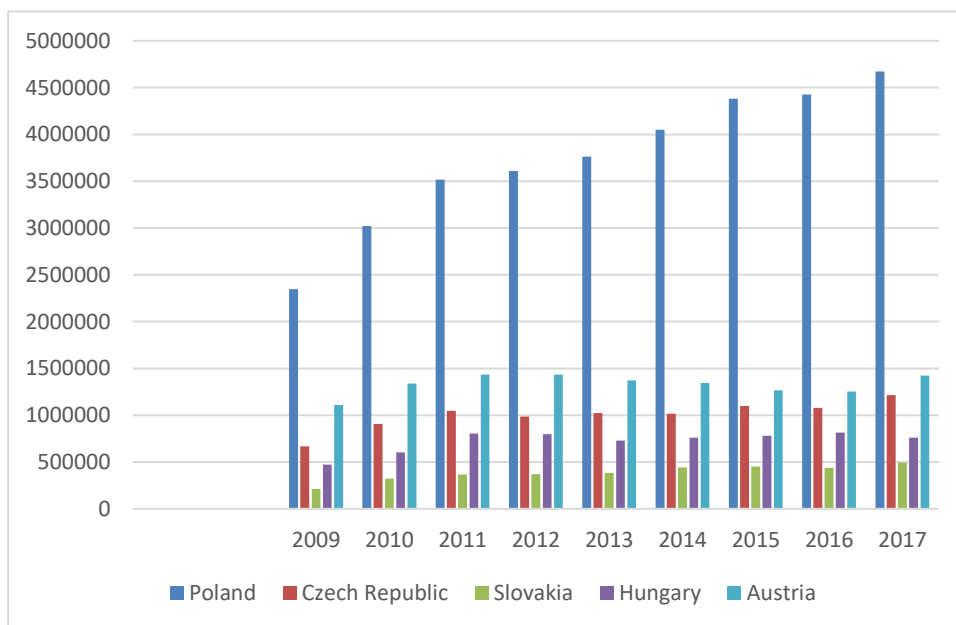

Figure 3: Import development to selected Central European countries from Sweden EUR thousand (own elaboration based on Eurostat database)

The commercial exchange between Central Europe and two other Scandinavian countries is lower in value and volume (Figure 4). Again Poland is the leading partner for Denmark and Norway with the highest level of commerce.

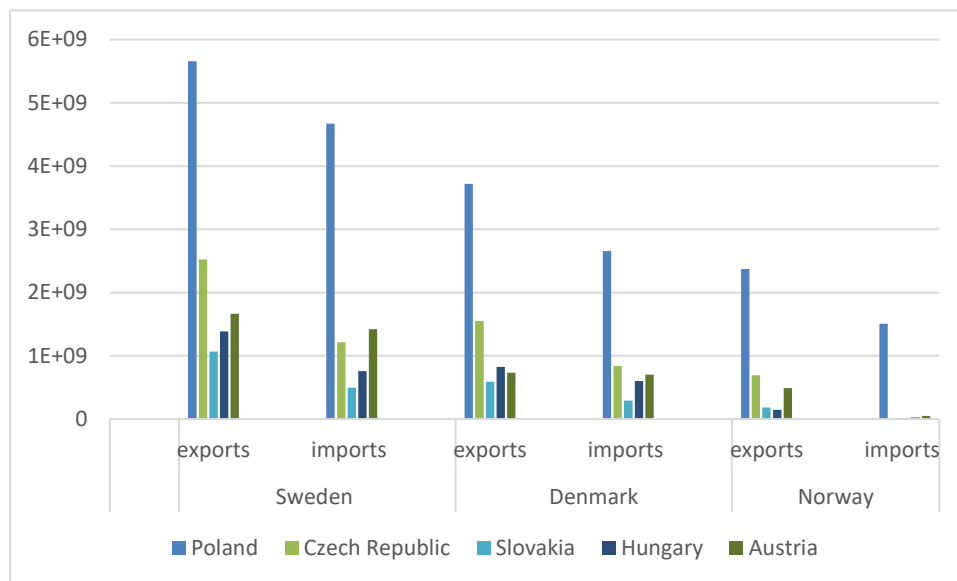

Figure 4: Exports and imports between selected Central European countries and Scandinavia in 2017- EUR (own elaboration based on Eurostat database)

The greatest share in export from Central European states to Denmark is represented by products of the electromechanical industry. Further, there are agricultural goods, foodstuffs, chemical and metallurgical commodities, as well as wood and paper industry products. The largest group in import consists of agricultural products and foodstuffs, products of electromechanical and chemical industry and light industry commodities. The exports to Norway from Poland comprises electromechanical products. This is mostly export connected with the shipyard industry. In imports dominate agricultural commodities and foodstuffs, in addition to the electromechanical industry.

5. THE POLISH FERRY MARKET

Polish ferry market comprises links to Sweden from ports of Gdynia and Gdansk located at East Coast and from Swinoujscie at West Coast. The services are as follows:

- Gdynia – Karlskrona (Stena Line),
- Gdynia – Nynashamn (Stena Line),
- Gdansk – Nynashamn (Polish Baltic Shipping Company – Polferries),
- Swinoujscie – Ystad (Unity Line),
- Swinoujscie – Trelleborg (Unity Line),
- Swinoujscie – Ystad (Polish Baltic Shipping Company – Polferries),
- Swinoujscie – Trelleborg (TT-Line).

Altogether 16 ferries ply these routes . The largest capacity is concentrated on the Swinoujscie - Ystad and Swinoujscie - Trelleborg, where 10 ferries are in operation. Other services are Gdynia - Karlskrona (4 ferries), Gdynia – Nynashamn (1 ro-pax) and Gdansk - Nynashamn with 1 ferry. The latter service will increase the capacity late June with chartered ferry Nova Star. The highest total turnover is observed from Swinoujscie to Ystad and Trelleborg. In 2017, 482 171 freight units (lorries and trailers) were carried on that sub-market. The turnover in the truck segment increased by 15% in compared to 2016.

The average yearly growth of cargo traffic in last decade amounted to 9% y/y. The traffic from Gdynia to Karlskrona and on new line to Nynashamn amounted to about 218 000 freight units in 2017 and recorded a 20% growth. Gdansk - Nynashamn is a niche sub-market where some 18 000 tracks were carried.

Table 1: Cargo units transported by ferries between Poland and Sweden in 2013-2017 (own elaboration based on Shippax Market 2017, Shippax Market 2016, Shippax Market 2015 and carriers data)

Route	2013	2014	2015	2016	2017
Swinoujscie - Ystad/Trelleborg	326035	358 762	376 353	425 850	482 171
Gdynia - Karlskrona	102849	116 828	148 648	180 474	218 011
Gdansk - Nynashamn	8548	9 263	12 963	16 082	-

The rise of transported units resulted from increase of trade exchange, particularly of Polish intercourse. The growth of ferry traffic in last 5 years was higher compared to international commerce as it has been affected by other factors as well. Significant investments in road infrastructure have been made over the last decade. Construction of network of motorways and highways has facilitated the access to terminals and largely determined the demand for transportation of transit cargo. The Czech and Austrian hauliers used to travel to Scandinavia primarily via connections from Germany (Rostock – Travemunde and Rostock – Gedser). The congestions in German roads contributed to transfer the cargo flows further East and affected the Polish ferry market. According to carriers` data, the average share of transit lorries has grown from 11 % in 2013 to nearly 20% in 2016. In Swinoujscie among transit Czech and Austrian trucks dominate, the others are Hungarian, Slovakian, and Romanian. Gdynia recorded primarily Slovakian, Czech and Hungarian lorries. The link from Gdansk to Nynashamn nearby Stockholm is specific as the transit time is long (16-17 hours) and transit commodities are transported from all Central Europe to agglomeration of Sweden capital and further north. Growing demand for freight service generate the need for cargo capacity. Currently, operators are facing deficiency in load line. The use of the available capacity for individual operators in 2016 was at the level of 70-80%, which means that there is no space reserve. The imbalance in mutual exchange impact the utilization of cargo capacity. The higher outward traffic stimulate the frequency of crossings. To meet the growing demand, the carriers have to increase the transport ability introducing new ro-pax ferries. Ferry traffic in Poland is concentrated in 3 terminals. The largest, both in terms of turnover and available infrastructure, is located in Swinoujscie. The terminal has 6 berths with ro-ro ramps. Nevertheless currently its traffic capacity is insufficient. In 2017 total 3576 calls were registered, up 9- 12 calls daily. At the terminal infrastructure investments are planned to adapt the potential to the growing volume and support for intermodal transport. In Gdynia ferry terminal is located in Western part in the immediate vicinity of container terminals. The infrastructure limits the capacity of the terminal due to length of berths and parking space as well as number of calls 4-5 daily. The new public terminal is under construction and is planned for 2020. The terminal will be fitted with double ramp enable the simultaneously loading and discharging. The only terminal with currently sufficient infrastructure is operated in Gdansk, where berth is fitted with 3 ramps.

6. CONCLUSION

Commercial intercourse between Central Europe and Scandinavia is showing an upward trend and a further increase in mutual exchange of goods is expected. The growth in trade volumes largely determines the demand for cargo transport from Poland to Scandinavia and affected

the ferry traffic. However the level and structure of commodity exchange is not the only factor. The construction of modern road network and high quality of ferry services are important drivers. Polish terminals and ferry connections have become the key nodes and links in land-sea transport chains.

LITERATURE:

1. Eurostat database. 12.05.2017.
2. Fedyunina, A. (2016). Trade liberalisation and its impact on regional development: theoretical and experimental studies. *Baltic Region*, Vol. 8, No 3. 20.04.2017 from <https://www.researchgate.net>.
3. Grzelakowski, A.S. (2010). Maritime transport development in the Baltic Sea Region. A.Weintrit (ed.), *Scientific Journal of Gdynia Maritime University, No 67*. Gdynia: WAMG (in Polish).
4. Kosov, Yu., Gribanova, G. (2016). Strategy for the Baltic Sea Region: Challenges and perspectives of international cooperation, *Baltic Region*, Vol. 8, No 2. 20.04.2017 from <https://www.researchgate.net>.
5. Kotilainen, M., Nikula, N. (2010). Why do firm invest in the Baltic Sea Region, *ETLA discussion paper, No. 122*. Leibniz: Information Centre for Economics.
6. Kotowska, I. (2014). *Żegluga morska bliskiego zasięgu w świetle idei zrównoważonego rozwoju transportu*. Szczecin: WNAM. (in Polish).
7. Laaser, C.F., Schrader, K. (2017). International trade in the Baltic Sea Region. In K. Liuhto (ed.), *The economic state of the Baltic Sea Region*, Turku: Centrum Balticum Foundation.
8. Mezhevich, N.M., Kretinin G.V., Fedorov G.M. (2016). Economic and geographical structures of the Baltic Sea Region, *Baltic Region*. Vol. 8, No 3. 20.04.2017 from <https://www.researchgate.net>.
9. Musso, E., Paixao Casaca, A.C., Lynce A.R., (2010). Economics of Short Sea Shipping. In C. Grammenos, *The Handbook of Maritime Economics and Business*. London: Lloyd's List.
10. Nakamura, H.R., Olsson, M., Lonnborg, M. (2012). FDI in the post-EU accession Baltic Sea Region: A global or a regional concern? *Baltic Journal of Economics* Vol. 12, No2.
11. Paixao Casaca, A.C., Marlow, P.B. (2009). Logistics strategies for short sea shipping operation as part of multimodal transport chains, *Marine Policy and Management*, 36(1).
12. Przybyłowski, A., Studzieniecki, T. (2017). Baltic Sea Region cities advancing towards sustainable urban mobility – Copenhagen and Gdynia case studies. *Conference Proceedings: 6th Central European Conference in Regional Science*. Banska Bystrica.
13. Purju, A., Branten, E. (2013). The Economies of the Baltic Sea Region: Growth Patterns and Foreign Trade Now and in the Future. *Journal of East-West Business*. No 19.
14. Serry, A. (2014). Dynamics of maritime transport in the Baltic Sea: regionalisation and multimodal integration. *Conference Proceedings, Conference: Maritime Transport Conference 2014*. Barcelona.
15. Shippax Market 15. (2015). The 2014 Ferry, Cruise, Ro-Ro and High-Speed Year in Review Analyses and Statistics. Halmstad: Shippax.
16. Shippax Market 16. (2016). The 2015 Ferry, Cruise, Ro-Ro and High-Speed Year in Review Analyses and Statistics. Halmstad: Shippax.
17. Shippax Market 17. (2017). The 2016 Ferry, Cruise, Ro-Ro and High-Speed Year in Review Analyses and Statistics. Halmstad: Shippax.
18. Stapford M. (2009). *Maritime economics*. London-New York: Routledge Taylor & Francis Group.
19. Tiiu Paas, T., Tafenau, E. (2005) *European trade integration in the Baltic Sea Region - A gravity model based analysis*. Hamburg: Hamburg Institute of International Economics.

CAN BITCOIN BE THE FUTURE OF DIGITAL PAYMENTS?

Andrea Valente

*Pearson College London
190 High Holborn, London, WC1V 7BH, United Kingdom
av150@pearsoncollege.com*

David Atkinson

*Pearson College London
190 High Holborn, London, WC1V 7BH, United Kingdom
david.atkinson@pearsoncollege.com*

John Clifford

*Pearson College London
190 High Holborn, London, WC1V 7BH, United Kingdom
john.clifford@pearsoncollege.com*

ABSTRACT

This study aimed to investigate the conditions in which Bitcoin has developed as a leading cryptocurrency and, according to Nakamoto (2008), could become an instrument for everyday payments around the world. In comparison to other digital payment solutions, Bitcoin is based on a peer-to-peer electronic cash system using ‘the blockchain’. This innovative technology allows for decentralised storage and movement of currency in a fully anonymous way, introducing advantageous methods for encrypted security and faster transactions (Hagiu and Beach, 2014). Scepticism regards Bitcoin’s foundation, energy consumption and price volatility, however, did not take long to arise (Holthaus, 2017). Ten years from its white paper release, Bitcoin is further supported by the same drivers which could sustain its growth as the future of digital payments (Russo, 2018). In order to investigate the key drivers and feasibility of acceptance, a London based survey was used to understand the desirability of Bitcoin as a day-to-day tool for digital payments. Additionally, this research analysed Bitcoin’s stakeholders and forecast drivers of sustainability for its application to become the future of the payment industry. A space which relies on policies that involve multiple layers of society, governments, regulators and tech-firms, all on a global scale. The findings confirmed how the increasing lack of trust of political and financial institutions, coupled with the increasing cases of data-breaches by tech-firms, encouraged over 70% of respondents to consider more decentralised and anonymous methods for their day-to-day actions; like payments. Policy makers need to cope with societies increasingly separating politically but gathering together digitally (LBS, 2017). For Bitcoin to truly establish itself as a global digital payment solution, key stakeholder acceptance must converge alongside the introduction of more robust regulation.

Keywords: *Bitcoin, Digital Payments*

1. INTRODUCTION

The term Bitcoin was coined for the first time on October 31, 2008. Satoshi Nakamoto, a figure whose identity is still somewhat a mystery, released an introduction document (“White Paper”) showcasing the feasibility of a Peer-to-Peer electronic cash system. By being the pioneer of the cryptocurrency era, Bitcoin initiation was characterised by a turbulent five years period in which transactions and integrations lacked to evolve (it took exactly 1789 days for Bitcoin to reach \$1,000 in value from its first trade - Appendix 3).

The three years following the thousands dollar price milestone were characterised by extensive yet “damaging” media coverage that led to price fluctuation and questions around the trustworthiness of Bitcoin

2. BITCOIN: GROWTH DRIVERS

2.1. Avoidance of Central Authorities due to increasing lack of Trust

After 2008 financial crises the overall financial system built of central and corporate banks was questioned. Furthermore, trust on politicians since these events has dramatically decrease, as often alleged of corruption by various corporates looking at greedy profits. As the great stock market depression in 1929, the first financial crises of the internet era was paid at the expense of the general public [taxpayers], \$700 billion in the US alone (Kimberly, 2017). The Dodd-Frank, Consumer Protection Act and humongous sanctions to Wall Street banks were some of the actions taken by Barack Obama in 2010 as a result. In Europe, the first solid legislative action would be a revisited version of the already existing MiFID (in fact called MiFID 2) that has come into force on January the 3rd, 2018. Governments have taken massive actions to limit and control the day-to-day activities of financial institutes however each bank (by being a business for its nature) would always seek the best for their customers’ profit [and their own]. The general opinion gathered from a sample of 28 individuals surveyed in November 2017 (Appendix 2) showed how banks lack in earned trust from its consumers (rating them as 60% on trustworthiness) as the dilemma if these events could happen again is not yet resolved. There is no question about the strategic period in which Bitcoin white paper was released (45 days after Lehman Brothers filed for corruption on September 15, 2008). Many consumers and neo-unemployed finance professionals saw Bitcoin as the innovative turning point for the future of finance. By being unbounded to third parties, the digital currency provided oxygen for ingenious thoughts in the polluted Wall Street environment of that time [and some still argue if conditions nowadays really have changed]. This driver provides to Bitcoin and its crypto currencies peers a solid foundation of general consensus within different society-layers.

2.2. Technology of the Third Millennium: The Blockchain

From its disrupted nature, Bitcoin was hatched as a defiance action. The technology that made it possible is the Blockchain (or originally the “Block Chain”) represent a universally accessible digital ledger. This third millennium technology brings to the simple task of tracking records within an active system (in which each record is called “block” and can be only added to the end) the link to one of each block using cryptography. In order for each block to be added onto the chain three requisites must be present:

- Link to the previous block – to confirm the proof of work
- A timestamp – to avoid double spending
- Transaction data (amount of data transferred – e.g. 7 Bitcoins)

It is fundamental that all miners have access to the same updated version of the Bitcoin blockchain all the transactions are irreversible. Bitcoin miners are the key subjects in the network, investing heavily in energy, hardware, time etc. and by completing all transactions certifications practicing “good conduct” - miner is the individual who verifies transactions and add a record into the to the public ledger (Kelleher, 2018). It can be however possible that a small group of miners bypass the blockchain trusted system and validate each other transactions going around double spending (the bigger the amount of miners in arrangement the small the probability other miners notice it, hence smaller the probability events like this happen). Bitcoin unofficial catchphrase “In Cryptography we trust” (Peck, 2017) provides a brief explanation of the importance of this technology for the development of trust in the increasing “boom” of cryptocurrencies.

Background agreements and transactions approvals are now replaced by high-level software, secure and distributed throughout every digital user of the internet. The Blockchain has limitless monetary developments for bitcoin, and the Ethereum Virtual Machine is now leveraging its potential for building software on top of it. From identity verifications to administrative burdens, from transaction speed optimisation to voting mechanism, the Ethereum Blockchain platform could replace sections of the world's most popular apps (Uber, Netflix, Google Drive, AIG etc.) and revolutionise the way we think about technology (Russo, 2017).

2.3. Community, Accessibility and Transparency: a new Privacy Model

Satoshi Nakamoto created a system where each individual can act as a miner but required to provide costly proofs in order to be repaid for their work. This peer-to-peer system has also resolved a problem that has vexed the digital environment for years: consensus. (E. Peck, 2017) The openness of the bitcoin blockchain network has attracted an ever-growing number of alike individuals that have a mutual interest: the establishment of the ever-growing decentralised monetary system. Not identical but similar, is the shared digital encyclopaedia example, Wikipedia.com: articles, like blocks, could be created by every user, however is the community overlooking the system and preventing mistakes (like the process of verification of transaction) the additional intrinsic value of the system. Activities, values and sustainability of the two digital platform are analysed in the table in Appendix 15. People have supported a different approach to privacy omitting the “trusted” third-party and supporting cryptography and anonymity where possible. With the current bitcoin technology, all the transactions (with respective amounts) taking place are publicly displayed on the blockchain yet senders and receivers are kept anonymous by crypted code-names. The biggest threat of this modern privacy system is the chronological history: if the actual corporate or individuals connected with the anonymous account would be released, all its activity history would be displayed. As many of other data driven technology advancements, potential leaks could provoke higher level of exposure compared to the older system, since its nature being fully cloud-based.

2.4. Digital and Physical Trends: No Barriers vs. Political Independence

In 2017 we trusted hairdressers more than our political or business leaders, leaderships surveys of London Business School support (LBS, 2017). With the primary data gathered from a digital survey to 28 individuals based in London (Appendix 2), some interesting patterns and correlations have been identified. A slightly negative correlation was found (-0.2 coefficient) between the likelihood of using bitcoin in the next 10 years and the level of trust in their bank to manage their money, similar result with the level of trust in central banks to prosper national economy (-0.18 coefficient). This indicates that the young community surveyed (mostly student, 90% under 25) is more likely to start using bitcoin if they feel a lack of trust on both their personal and England's central bank. Additionally, the 82% of the individuals that confirmed their full understanding on the Bitcoin environment did declare they have already completed their first investment in Bitcoin (in fact Complexity has been ranked in the last question of the survey as the 1st barrier to entry for the general public). While the UK political panorama has been characterised by an increasing independence sentiment due to Brexit events, the amount of people interviewed confirmed how the financial system should be more transparent and connected in the future (71% voted 5 or above on the likelihood they will use Bitcoin in the next 10 years, in a scale of 10). It is curious to see that, even though 71% of the 28 individuals surveyed are not happy with the results of the referendum, societies are increasingly separating politically but gathering together digitally. 24 out of 28 people surveyed confirmed that “Immigration” was the first reason why the UK citizens were supporting Brexit in June 2016; confirming that we are in a transitional decade in which digital communities and financial advancements are making us feel more connected than human to human dialogue and

diversity welcomeness. The four main key drivers of change analysed above interact with the competencies and resources of Bitcoin directly. Competencies and additional characteristics are briefly listed in the SWOT analysis attached in Appendix 14.

3. ANALYSIS OF DIGITAL PAYMENT INDUSTRY AND BITCOIN DESIRABILITY

The origin of the digital payments industry is associated with the born of the internet in 1969 with ARPANET. While the internet took several years to develop from a military based tool to a cross-society asset, the Stanford Federal Credit Union had the aim to digitalise cash in form of e-money, token or virtual currency (Tsosie, 2017). In 1998 PayPal, current market player, began as a mobile payment firm, however it then switched to a fully oriented digitised payment platform with the EBay acquisition in 2002 (Scott-Briggs, 2016). However, vast of the digital payments industry development has been possible thanks to credit and debit cards. Starting from 1958, various companies in the US started to launch different chip-related plastic cards however Bank of America took the lead as the most innovative. “BankAmericard” became popular mostly because of its large baskets merchants accepting the newly introduced system, especially in California. For the first two decades most of the regulations around credit cards interest for example remained murky and largely unknown; to the cost of the consumers. BankAmericard then became Visa and its life-competitor, MasterCharge, evolved to MasterCard. These two providers are now processing over 90% of transactions (Appendix 6) and while acceptance was largely growing in the first two decades, the following regulation period in the US (ended with the approval of the Card Act of 2009) structured the environment for the genuine and spontaneous growth of a technology fulfilling the demand and behavioural changes of evolving human beings. Today, Bitcoin infancy can be compared to the early 1960s in which credit cards and digital payments were ideological concepts with good purpose but wide uncertainty. As shown in Porter’s 5 Forces Model (Appendix 8), the digital payments industry is characterized by large market players and high competitive rivalry. The attractiveness of the industry is also high, and few firms have developed between the current existing network and the new crypto environment. TenX for example is a direct competitor of the current digital payments suppliers and enables its users to openly connect their Bitcoin/Ethereum/Litecoin wallet and spend these cryptocurrencies via a normal debit cards (TenX branded). At the moment of payment in any worldwide merchant the card fetch the FIAT currency requested amount and converts it to the previously selected crypto in usage at current market rate. (e.g. £50 payment would deduct “0.004194” bitcoin - at a bitcoin market value of £11,917). The desirability of bitcoin in such industry however is highly questionable. The reason why is the lack of fundamental basis for Bitcoin valuation and other cryptocurrencies; in fact the price of Bitcoin has increased by nearly 1,000% in 2017 alone (coinmarketcap.com, 2018). Morgan Stanley analyst James Faucette has recently released a report to various MS clients stating that the actual value of Bitcoin could be \$0 (Edwards, 2017). To provide a desirability example (Appendix 11), some data gathered from a survey on renewables energy outlook gathered in 2016 has been compared to the the Bitcoin data gathered in the survey in Appendix 2. Individuals in both cases were asked about their expectations, on a scale from 1 to 10, whatever they would use Renewables/Bitcoin in 10 years’ time. Renewables are expected to be part of daily lives on a 7.2 average, compared to 6.1 for Bitcoin. On both cases the two technologies are developing at the damage of old-established environments (fossil fuel energy for renewables and the banks based financial system for bitcoin). The two realities are often covered by the media and they do nurture an interest in the public. However, the desirability on both cases does depend on how the technology develops in the future and the only variable to which desirability is vastly linked is one: time. Additionally, Bitcoin and various other cryptocurrencies do not have a matured, regulated and tested underlying market. The products and their markets have existed for fewer than 10 years and bear little if any relationship to any

economic circumstances or reality in the real world (Peterffy, 2017). The second issue as of January 2018 is a socio-conceptualisation controversy. It is still unclear whether Bitcoin today is seen as a digital currency for payments or as a traditional “asset” to invest in for merely speculative reasons. Credit Suisse’s current CEO Tidjane Thiam declared in November 2017 that “investors are only buying into the digital asset to make money, and described it as the very definition of speculation and the very definition of a bubble” (Brown, 2017). Surely the blockchain technology and its application into decentralised cryptocurrencies, such as the Bitcoin, is a clear advancement compared to the old basket of FIAT currencies that are now mostly underling to “thin air” and are fully controlled by countries central banks. While digital acceptance of Bitcoin as a way of payment lacks to take off (Appendix 10) it is clear that it would take some time for cryptocurrencies to settle in this high competitive industry; as ARPANET took decades to become part of our daily lives bitcoin could be subject to the similar technological and social acceptance time digestion. The Porter Generic Strategy matrix has been used below to highlight the current positioning of the major players operating in the digital payments industry [and crypto forecasted].



Figure 1: Porter Five Forces for Digital payments (Brown, 2017)

4. BITCOIN: STAKEHOLDER ANALYSIS AND STABILITY EVOLUTION

There is a large amount of individuals and organizations that are increasingly identified as Bitcoin stakeholders. Using a power/interest grid we can obtain a matrix of the current stakeholders positioning. 21 stakeholders have been identified to be related to the Bitcoin environment:

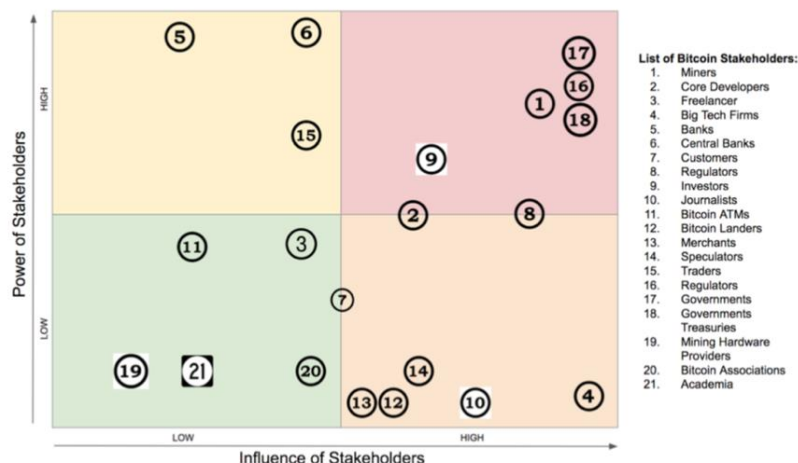

Figure 2: Bitcoin Stakeholder Power/Interest Grid (LBS, 2018)

The list of Bitcoin stakeholders is expected to evolve in pair with the development of the same cryptocurrency and its applications. The progress of the positioning of the stakeholders listed above is mainly affected by the events and activity expansions of six of them in particular. A power/interest grid with the future trends outlook in regards to their positioning can be found below. A thorough examination of the main stakeholder can be found in Appendix 17.

1. Miners - Identified as individuals, groups or companies who provide computer power to mine and record the transactions. Miners are probably, after regulators, the most critical individuals within the Bitcoin stakeholder environment.
2. Big Tech Firms - Firms like IBM, Microsoft, Amazon, Google etc. are developing new technologies to leverage the blockchain into food distribution or driverless cars for example. (Russo and Katz - Bloomberg, 2017)
3. Central Banks - As previously mentioned in Appendix 1, European Central Bank president Mario Draghi has already stated how the ECB is studying on thorough regulations providing for the conditions of a healthy development of the new financial systems.
4. Customers / Investors - Consumers are the key driver of development of Bitcoin to become a global digital payment solution. Investors logically suppose to understand and believe in the principle of Bitcoin being a concrete substitute of current online payments systems, however most of them did enter the environment for speculative reasons (as mentioned in Question 2).
5. Traders / Investment Banks - Traders are largely affecting the Bitcoin environment by increasing the number of exchange and financial products related with the crypto currency. ETF (Exchange Traded Funds) or Futures, for example, are expected to be traded with more frequencies and in large volumes in 2018. (Bloomberg, 2017)
6. Regulators / Governments - The cryptocurrency community is eager for clarity from regulators on ICO, trading, mining and taxes; as that happens more investors and end-users could dip their toes in the water. (Russo and Katz - Bloomberg, 2017)^[1] Regulators are highly influential and do carry extensive amount of power from government and governments' treasuries.

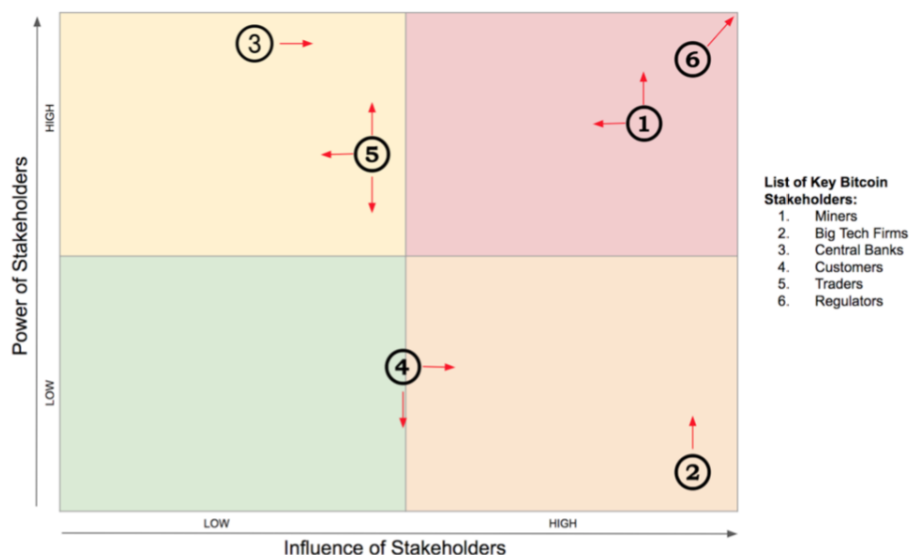

Figure 3: Key Bitcoin Stakeholder Power/Interest (LBS, 2018)

As shown in the power/influence matrix above all the stakeholders key players are in a position of instability and are expected to be increasing or decreasing both in influence and power on a

monthly basis; and while the volatility and uncertainty of Bitcoin application to the digital payment systems remains at current level this is very likely to continue. (LBS, 2018)

5. EVALUATION OF BITCOIN AS THE FUTURE OF THE DIGITAL PAYMENT INDUSTRY

Bitcoin has clearly large potential to disrupt a big part of the digital payments industry, and in developing countries there is a very high potential, too! Various internal and external factors limiting the currency have however become clear with its development. The list below evaluates the current factors that need to evolve in order for bitcoin to become [or not] the future of digital payments on a global basis:

- Regulations - from July 2017, the SEC regulator (US Security and Exchange commission) confirmed that US National Security Law may apply to some cryptocurrencies; without providing concrete guidelines on which cryptocurrencies in particular (Russo and Katz - Bloomberg, 2017). The current lack of national and international regulations of Bitcoin [and the crypto environment in general] represents one of the main reason why price volatility is very high and network integration is very low. A global digital payment system like PayPal would have never grown to the volumes and trustworthiness it has today with this much uncertainty.
- Market Maturity (Fear of “Bubble”) - bubble is a confusing term for bitcoin: If there is no fundamental value to compare the price to, who’s to say it’s too high? (Crane and Read, 2017) Market maturity extends to the amount and variety of services that we are seeing developed as well as the overall Bitcoin adoption. Additionally, the whole press sentiment around the globe would generally affect unsophisticated individuals’ adoption hence effect the pace of which Bitcoin could develop to a global payment instrument. As shown from the graph below, the phenomenon of adoption for Bitcoin is cyclical, and would largely depend on adoption of sophisticated individual, since this group is likely going to be the majority at the time of acceptance:

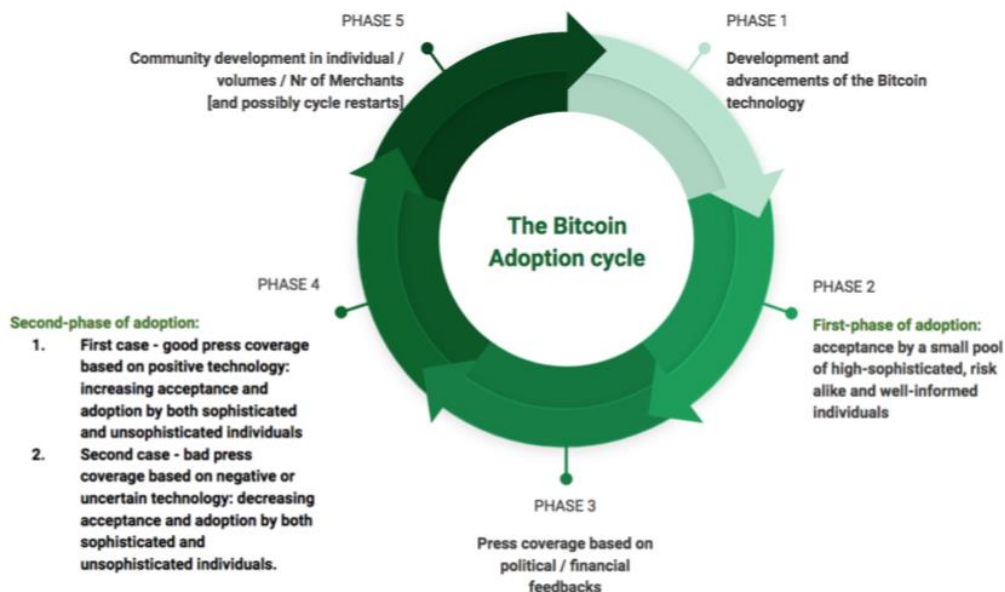

• *Figure 4: Digital Payment Industry Development Cycle*

- Speculative Investment trends - for Bitcoin to develop into a mature market and a trustworthy digital payment system the price needs to somehow stabilise within a certain “expected” range, therefore volatility needs to reduce to “average” levels.

- Technology and Infrastructure - transactions per seconds, on the technology side, are a big issue to resolve for the blockchain and its network. PayPal and Visa process an average of transactions that ranges between 200 and 1,600 per seconds. (Vermeulen, 2017) ^[17] Bitcoin alone can process a number of transactions that ranges between 3 and 7; reason why other cryptocurrencies have developed in this space trying to improve this inefficiency of Bitcoin (e.g. Ethereum with over 30 transactions per second, or Litecoin processing over 50-60 transactions per seconds). Up to this number, Bitcoin can only compete in digital payments niches where anonymousness is a critical requirement.
- Wallet / Transactions fees - another limitation for Bitcoin: for both wallet withdraws / deposit, and for transactions. (Appendix 12) Bitcoin transactions fees in particular are skyrocketing proved to be profitable for so-called bitcoin "miners". Slow transaction speeds and fees has led to a number of splits in the original blockchain as part of the community believe that the size of blocks - records of transactions on the network — should be increased (SegWit2x correction in the blockchain was suppose to increase the dimension of the blocks from 1 to 2MB - however this solution has then been dropped). (Browne, 2017)
- Acceptance of a “Market Leader” - 97% of people interview in 2017 living in the UK have confirmed that they did not use Bitcoin before (Appendix 4). Even though the majority of people have heard of it, a rarity section of the society has clearly found ways to leverage Bitcoin in their daily life. People believe the biggest limitation of the Bitcoin is the fact that there are no locations to spend it. A really discouraging example of low bitcoin acceptance can be found in Appendix 11 with less than 3 of the top 500 ecommerce website in the US currently accepting Bitcoin. However, the ATMs around the world are increasing in number and is really likely this would create traction in the environment.

An extensive section of in-depth details of some of the 6 factors presented above can be found in Appendix 19. So is clear how the acceptance / usage and well-constructed regulations are the main key drivers for Bitcoin development into the digital payment space. Concept-extensive and geographical-specific regulations would very likely need to precede the acceptance / usage in order for this last one to grow exponentially.

6. SUSTAINABILITY AND CHANGES AHEAD FOR THE DIGITAL PAYMENT INDUSTRY AND BITCOIN

The digital payment industry has been agile to adapt to various technological advancements in the last decade. Contactless payments, Apple/Google/Android-pay and the large development of gift cards [thanks to the exponential diffusion of Amazon] are just some of the advancements the digital payments industry has developed to meet evolving social behaviours leveraging technological advancements. The overall structure of the industry is proven to be solid and increasingly secure, by thousands of transactions completed every seconds by providers like MasterCard and Visa. The advent of the cryptocurrencies is not arguing this structure to be obsolete as a shared decentralised ledger would be more beneficial to security and integrations (mostly for the use of the blockchain). Our lives are increasingly moving to digital usage, and payment is one [if not the one] behaviour that we are going to do more and more digitally. The industry outlook for payments behaviours in the UK for example (Appendix 13) show how contactless payments (with debit card and other devices) are expected to surpass even the amount of times we use cash today. Smartphone and wearable devices are also expected to increase in usage for payments making it crucial for Bitcoin wallet providers to develop platforms for these devices too (1st possible Bitcoin response to changes). Bitcoin in every of its various environments (technological, financial, media coverage and many more) requires advancement for the development of a concrete sustainable competitive advantage benefitting the long term. Bitcoin however can be used in the future not just as a payment system but also

to store data, raise funds in poor countries, protect from inflations etc (Cheng, 2018). One of the biggest structural limitation for Bitcoin is however the current rate of energy consumption (Appendix 18), 2nd possible Bitcoin response to changes. Mining is certainly the biggest energy-consumption activity however by 2030 all the coins will be issued and just-transaction activities would require less power resources (If there would only be Bitcoin and no other coins). The reason being is that there will only ever be 21 million Bitcoin: the finite nature of the currency was Satoshi's way of making sure that, unlike the fiat currencies that governments are free to abuse, nobody could ever destroy the value of bitcoin by arbitrarily deciding to create more of it (Lanchester, 2016). In terms of future sustainability, it is really unlikely that an socio-tech-finance shift like the Bitcoin would happen again anytime soon since it would take a long time for it to settle and gain some space in a already extremely rival industry. What is more likely to happen is that Bitcoin would be surpassed by another coin like LiteCoin, Ripple or Ethereum as not being the first sometimes allows to develop competitive technology in the dark and avoid too much press; as happened in the history of the search engine industry for Google and in the smartphone industry for Facebook. Any action both in technology and usage would highly depend on regulations activities and social opinion around the bitcoin. In the scenario analysis below we can see how the two main factors affecting bitcoin expansion into the digital payments system provide a wide range of scenario that could happen in the future.

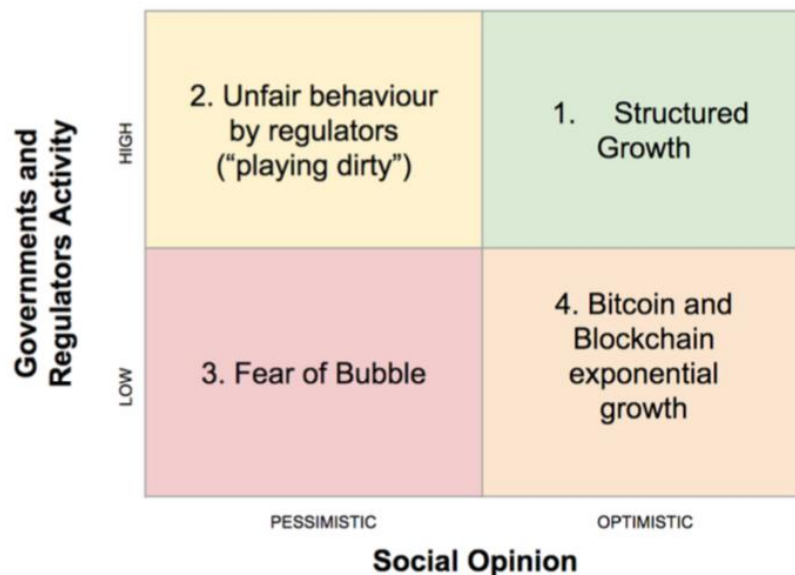

Figure 5: Bitcoin Sustainability Forces Grid (Lanchester, 2016)

After analysis the current drivers of growth, we position the current period (Jan-2018) in the exiting of stage 4 to move on stage 3. As soon as regulators would kick in the Bitcoin game, price is expected to drop and regulations would be probably increasing. Stage 2 is where regulators are normally found to be playing unfairly against the new technological trend and it would take a long time and various price drops to then arrive at stage 1. From the same ideology, the intrinsic value of a bitcoin [and its prosperity] is a genuine representation of the general consensus arrangements between the community practically using it. Same as currencies and financial asset prices (use for payments) work now: we know from the current market value that an ounce of gold is costs around \$1,300, so why is gold in financial markets worth anything more than the jewellery value of gold? It is the general consensus that supports the specific market price based on current market conditions. The future market outlook of Bitcoin would probably be characterised by various changes and increasing regulations; at least internal

technological changes are easily applicable: “any needed rules and incentives can be enforced with the mining consensus mechanism - miners will vote with their CPU power, expressing their acceptance of valid blocks by working on extending them and rejecting invalid blocks by refusing to work on them” - as we can read in Satoshi's Bitcoin white paper (Cheng, 2018). And until acceptance [and healthy regulations that comes with it] does not take an exponential route between individuals, merchants and companies around the world, the likelihood of a system for electronic transactions without relying on trust [the Bitcoin], becoming a global solution in the digital payments system, would remain highly unlikely.

LITERATURE:

1. Anon, (2017). Credit Card Eligibility Checker | American Express UK. [online] Location: <https://www.americanexpress.com/uk/credit-cards/eligibility-checker/> [Retrieved on 9 Jan. 2018].
2. Bernardi, D. (2017). Simulazione Montecarlo applicata al Bitcoin. [online] Diaman.it. Location: <http://www.diaman.it/blog/entry/simulazione-montecarlo-applicata-al-bitcoin.html> [Retrieved on 9 Jan. 2018].
3. Bitcoin News. (2017). It's Bitcoin's Birthday: Whitepaper Released 8 years Ago Today. [online] Location: <https://news.bitcoin.com/bitcoin-birthday-whitepaper/> [Retrieved on 9 Jan. 2018].
4. Browne, R. (2017). Banks are staying away from bitcoin 'bubble' due to money laundering, Credit Suisse CEO says. [online] CNBC. Location: <https://www.cnbc.com/2017/11/02/credit-suisse-ceo-banks-staying-away-from-bitcoin-bubble.html> [Retrieved on 9 Jan. 2018].
5. Cash Services. n.d. Share of consumer cash payments in the United Kingdom (UK) in 2006, 2016 and 2026* . Statista. Retrieved on 8 January, 2018. Available from <https://www.statista.com/statistics/420845/cash-payments-share-in-the-uk/>.
6. Cheng, E. (2018). Five predictions for digital currencies in 2018 — including stomach-churning drops, bitcoin-related IPO. [online] CNBC. Location: https://www.cnbc.com/2018/01/05/five-predictions-for-digital-currencies-in-2018.html?__source=facebook%7Ccrypto [Retrieved on 9 Jan. 2018].
7. Coin ATM Radar. n.d. Number of Bitcoin ATMs worldwide from January 2016 to January 2018. Statista. Retrieved on 7 January, 2018. Available from <https://www.statista.com/statistics/343127/number-bitcoin-atms/>.
8. Digital Currency Council. n.d. What do you think the biggest challenges are for the future of bitcoin as a digital currency?. Statista. Retrieved on 7 January, 2018. Available from <https://www.statista.com/statistics/605713/main-challenges-for-bitcoin-in-the-future-in-the-united-kingdom-uk/>.
9. Digital Currency Council. n.d. What do you think the biggest challenges are for the future of bitcoin as a digital currency?. Statista. Retrieved on 7 January, 2018. Available from <https://www.statista.com/statistics/605713/main-challenges-for-bitcoin-in-the-future-in-the-united-kingdom-uk>
10. Edwards, J. (2017). Morgan Stanley says the true price of bitcoin might be zero. [online] Business Insider. Location: <http://uk.businessinsider.com/morgan-stanley-on-bitcoin-value-2017-12> [Retrieved on 9 Jan. 2018].
11. En.wikipedia.org. (2017). Dodd–Frank Wall Street Reform and Consumer Protection Act. [online] Location: https://en.wikipedia.org/wiki/Dodd–Frank_Wall_Street_Reform_and_Consumer_Protection_Act [Retrieved on 9 Jan. 2018].

12. En.wikipedia.org. (2018). BitLicense. [online] Location: <https://en.wikipedia.org/wiki/BitLicense> [Retrieved on 9 Jan. 2018].
13. Holthaus, E. (2017). Bitcoin could cost us our clean-energy future. [online] Grist. Location: <https://grist.org/article/bitcoin-could-cost-us-our-clean-energy-future/> [Retrieved on 9 Jan. 2018].
14. <https://www.tenx.tech/company.html>
15. IEEE Spectrum: Technology, Engineering, and Science News. (2017). Blockchains: How They Work and Why They'll Change the World. [online] Location: https://spectrum.ieee.org/computing/networks/blockchains-how-they-work-and-why-theyll-change-the-world#disqus_thread [Retrieved on 9 Jan. 2018].
16. Kelleher, J. (2018). Bitcoin Mining. [online] Investopedia. Location: <https://www.investopedia.com/terms/b/bitcoin-mining.asp> [Retrieved on 9 Jan. 2018].
17. Lanchester, J. (2017). LRB • John Lanchester • When Bitcoin Grows Up: What is Money?. [online] London Review of Books. Location: <https://www.lrb.co.uk/v38/n08/john-lanchester/when-bitcoin-grows-up> [Retrieved on 9 Jan. 2018].
18. LBS (2017). Six trends to look out for in 2018 | London Business School. [online] London Business School. Location: https://www.london.edu/faculty-and-research/lbsr/six-trends-to-look-out-for-in-2018?utm_campaign=1025447_MC_LBSR_Emails_FY17_Dec_Themed_Prospect&utm_medium=email&utm_source=DotMailer&utm_content=Article%201&dm_i=2SVQ,LZ8N,2DH8KG,2AJ2S,1#.Wjt6mSOZMWO [Retrieved on 9 Jan. 2018].
19. Payments UK. n.d. Past and future number of payments in the United Kingdom (UK) in 2015 and 2025, by method (in millions). Statista. Retrieved on 9 January, 2018. Available from <https://www.statista.com/statistics/748499/payments-made-past-and-future-by-method-in-the-uk/>.
20. Peterffy (2017). BITCOIN FUTURE: THOMAS PETERFFY HA RAGIONE AL 100%. [online] Traglisqualidiwallstreet.blogspot.co.uk. Location: <https://traglisqualidiwallstreet.blogspot.co.uk/2017/11/bitcoin-future-thomas-peterffy-ha.html> [Retrieved on 9 Jan. 2018].
21. Raconteur. n.d. Share of different payment methods usage in the United Kingdom (UK) in 2017, by frequency. Statista. Retrieved on 8 January, 2018. Available from <https://www.statista.com/statistics/784352/consumer-payment-methods-uk/>.
22. Read, M. and Crane, J. (2017). Do You Really Know What Bitcoin Is?. [online] Select All. Location: http://nymag.com/selectall/2017/12/what-is-bitcoin-a-guide-for-the-confused.html?utm_source=GetTheElevator&utm_campaign=e64f8153ed-GetTheElevator-dot-com&utm_medium=email&utm_term=0_e6123ee6a2-e64f8153ed-19268495 [Retrieved on 9 Jan. 2018].
23. Russo, M. (2018). Goldman and Google Are Among the Most Active Blockchain Investors. [online] Bloomberg.com. Location: <https://www.bloomberg.com/news/articles/2017-10-17/goldman-google-make-list-of-most-active-blockchain-investors> [Retrieved on 9 Jan. 2018].
24. Russo, M. and Bloomberg (2018). Bitcoin: What's Coming in the Year Ahead. [online] Bloomberg.com. Location: <https://www.bloomberg.com/news/articles/2017-11-01/bitcoin-what-s-coming-in-the-year-ahead> [Retrieved on 9 Jan. 2018].
25. Scott-Briggs, A. (2017). What is Digital Payment, origin and history in financial technology? | TechBullion. [online] TechBullion. Location: <https://www.techbullion.com/what-is-digital-payment-origin-and-history-in-financial-technology/> [Retrieved on 9 Jan. 2018].

26. Space, R. (2017). Republic Crypto: Bringing Inclusivity to the Blockchain Space. [online] Republic.co. Location: https://republic.co/blog/republic-crypto-bringing-inclusivity-to-the-blockchain-space?utm_campaign=platform-newsletter-111317&utm_content=main-content-link&utm_medium=email&utm_source=platform-newsletter [Retrieved on 9 Jan. 2018].
27. The Balance. (2018). What Caused the 2008 Financial Crisis and Could It Happen Again?. [online] Location: <https://www.thebalance.com/2008-financial-crisis-3305679> [Retrieved on 9 Jan. 2018].
28. The Nilson Report. n.d. Market share of leading credit card brands in terms of purchase volume in Europe as of 2015 and 2016. Statista. Retrieved on 7 January, 2018. Available from <https://www.statista.com/statistics/619376/market-share-purchase-volume-of-credit-card-brands-europe/>.
29. Tsosie, C. (2017). The History of the Credit Card - NerdWallet. [online] NerdWallet. Location: <https://www.nerdwallet.com/blog/credit-cards/history-credit-card/> [Retrieved on 9 Jan. 2018].
30. TSYS. n.d. How familiar are you with virtual currencies such as Bitcoin?. Statista. Retrieved on 7 January, 2018. Available from <https://www.statista.com/statistics/787170/bitcoin-familiarity-uk/>.
31. Vermeulen, J. (2017). Bitcoin and Ethereum vs Visa and PayPal – Transactions per second. [online] Mybroadband.co.za. Location: <https://mybroadband.co.za/news/banking/206742-bitcoin-and-ethereum-vs-visa-and-paypal-transactions-per-second.html> [Retrieved on 9 Jan. 2018].
32. Wikipedia (2018). Blockchain. [online] En.wikipedia.org. Location: <https://en.wikipedia.org/wiki/Blockchain> [Retrieved on 9 Jan. 2018].

MATERIALITY IN ACCOUNTING AND AUDITING

Iwona Kumor

*University of Economics in Katowice, Poland
iwona.kumor@ue.katowice.pl*

Ewa Mackowiak

*University of Economics in Katowice, Poland
ewa.mackowiak@ue.katowice.pl*

ABSTRACT

The principles of accounting, also referred to as concepts or assumptions, constitute the rules for keeping accounting books and preparing financial statements in order to ensure the reliability and usefulness of information provided by accounting. Materiality as one of these principles contributes towards this goal. Accounting as an information system is founded on these principles, conventions and practices, which originate in the attempts to satisfy the information needs of users of financial statements in terms of the actual financial and economic situation of an economic entity (Kumor, 2014, p.410). The article discusses the principle of materiality, its nature and importance in accounting and auditing. It aims to present the importance of the principle of materiality in accounting and auditing. Based on the analysis of literature and legal acts, the article argues that the application of the principle of materiality in accounting allows for simplifications while maintaining a true and fair picture under the accepted accounting principles (policy) without detriment to the usefulness of information presented in the financial statements. Materiality in financial audit determines financial and non-financial misstatements. The level of materiality, in turn, enables the auditor to define the scope of financial audit procedures and constitutes an important reference for the assessment of the effect of the misstatements in the financial statements revealed by the auditor and their impact on the reliability of financial statements. The verification of these hypothesis was conducted with the use of such research tools as the analysis of literature and legal acts.

Keywords: *accounting principles, materiality, financial statement, accounting, auditing*

1. INTRODUCTION

The principles of accounting, also referred to as concepts or assumptions, constitute the rules for keeping accounting books and preparing financial statements in order to ensure the reliability and usefulness of information provided by accounting. Materiality as one of these principles contributes towards this goal. Accounting as an information system is founded on these principles, conventions and practices, which originate in the attempts to satisfy the information needs of users of financial statements in terms of the actual financial and economic situation of an economic entity (Kumor, 2014, p.410). The financial statements are the most comprehensive source of information about the financial position and performance of the entity. It is a practical carrier of financial information that allows for the systematic analysis of data. The current activities and efforts in the area of the financial statements preparation are aimed at minimizing the asymmetry between the information received by an entity's shareholders and management board and the information presented to external users by increasing its transparency and, hence, its quality and usefulness (Śnieżek, Wiatr, 2016, p. 207). This allows entities to make simplifications under the accepted accounting principles (policy). As a result, disclosure of information in the financial statements requires compliance with the principle of materiality. The materiality guidelines stipulated in IAS 1 indicate the possibility of aggregating and disaggregating information presented in the main part of the financial statements, as well as in the notes, in order to ensure the usefulness of information to its users.

The form of presentation and its comprehensiveness should be adequate to relevant facts and circumstances. These guidelines also apply to disclosures resulting from particular standards. The aim, or the ambition, of financial audit is the increased trust of users of financial statements in the information with which they are presented. This objective is accomplished through the detection of material misstatements. Materiality is therefore the limit of the auditor's willingness to tolerate the financial reporting misstatements without demanding corrections. The article discusses the principle of materiality, its nature and importance in accounting and auditing. It aims to present the importance of the principle of materiality in accounting and auditing. Based on the analysis of literature and legal acts, the article argues that the application of the principle of materiality in accounting allows for simplifications while maintaining a true and fair picture under the accepted accounting principles (policy) without detriment to the usefulness of information presented in the financial statements. Materiality in financial audit determines financial and non-financial misstatements. The level of materiality, in turn, enables the auditor to define the scope of financial audit procedures and constitutes an important reference for the assessment of the effect of the misstatements in the financial statements revealed by the auditor and their impact on the reliability of financial statements. The verification of these hypothesis was conducted with the use of such research tools as the analysis of literature and legal acts.

2. THE CONCEPT OF MATERIALITY IN THE ACCOUNTING AND AUDITING REGULATIONS

The principle of materiality as one of the primary accounting principles constitutes the rules for keeping accounting books and preparing financial statements in order to ensure the reliability and usefulness of the information provided by accounting (Dobija ed. 2005, p. 175). Information can be considered material if access to such information can be of importance to users of financial statements. Materiality can also be seen as the limitation of the scope of information disclosed (Hendriksen van Breda, 2002, pp. 62-163). Pursuant to the Accounting Act, an entity complying with the provisions of the Act art. 4 para. 4a applies the principle of materiality. This is manifested by the fact that under the accepted accounting principles (policy) an entity may apply simplifications provided this does not adversely affect a true and fair view of their property and financial standing as well as financial result, while maintaining the conservative accounting principle (art. 4 para. 4; art. 8 para.1, Accounting Act). Information disclosed in financial statements and consolidated financial statements is deemed material, in compliance with the Accounting Act, when its omission or misstatement may affect decisions made on its basis by users of these statements. The Act also indicates the need to combine items of similar nature while determining their materiality (art. 4 para. 4a, Accounting Act). Similarly, international financial reporting standards underline the fact that an entity is not obliged to disclose certain information required by these standards unless it is materially important to users of financial statements even if the "minimum scope" of disclosures is specified. These standards allow collective or specific presentation depending on the relevant facts and circumstances if, either individually or collectively, they do not affect business decisions made by their users based on financial statements. This materiality applies both to the main part of the financial statements as well as the notes and other disclosures required by the standards (IAS 1, 2016, para. 29-31). In the Conceptual Framework of financial reporting, materiality is defined in a similar way as a factor limiting the usefulness of financial information to its users (Conceptual Framework, 2016, para. CJ11). The "EU Directive on disclosure of non-financial and diversity information" also applies to the issue of materiality. The Directive lists important non-financial issues that should be disclosed by entities and these are: environmental and social issues, employee related issues, human rights issues and counteracting corruption and bribery. These issues should be disclosed in accordance with the Directive to the extent enabling the

assessment of the growth, performance and financial standing of the entity and the impact of measures taken in this area. In determining the scope of this information, materiality is of crucial significance. According to the directive, all relevant information for its users should be disclosed in the financial statements, which will translate into improved internal and external decision-making processes. The application of the principle of materiality when disclosing non-financial information is more complicated than in the case of financial information. This is due to the fact that it is not possible to apply financial thresholds to determine the level of materiality for various types of non-financial information. Therefore, there is an increased risk of divergent judgments on materiality by reporting agents, auditors and users of non-financial information (EU Directive, 2016, pp. 7-14). Kabalski points to two aspects of the materiality of information: quantitative and qualitative. The quantitative aspect refers to the size of an economic event, while the qualitative aspect is related to its nature (Kabalski, 2016, p. 4). The principle of materiality, as expressed in accounting regulations, manifests itself in the application of simplifications provided they do not have a negative impact on decisions made by users of financial statements. Persons responsible for accounting and the preparation of financial statements can, under the accepted accounting principles (policy), apply simplifications, while complying with the principle of materiality. The simplifications defined in accounting regulations can be classified according to various criteria. Selected criteria and types of simplifications are presented in Table 1.

Table 1: Classification of simplifications (selected criteria) according to accounting regulations (own elaboration based on Kabalski, 2016, pp.5-10)

Criterion	Type of simplification
Nature of simplification	- uproszczenia mające charakter zasady ogólnej - uproszczenia mające charakter szczegółowy - general simplifications - specific simplifications
Types of events and groups of units	- uproszczenia podmiotowo-przedmiotowe - uproszczenia przedmiotowe - subjective and objective simplifications - subjective simplifications
Scope of disclosures	- uproszczenia w zakresie ujawnień informacji finansowej, - uproszczenia w zakresie ujawnień informacji niefinansowej - simplifications concerning financial information disclosures, - simplifications concerning non-financial information disclosures

General provisions, relating to the possibility of applying simplifications, are included in the international standards and the Accounting Act. Additionally, the Act contains a number of specific provisions that allow particular simplifications of subjective or objective nature. They stipulate that the requirements contained in individual standards or the act do not have to be applied if the effect of their application is not material (Kabalski, 2016, p. 5). The scope of simplifications applied by an entity also depends on the regulations that the entity adopted: IFRS or the Accounting Act. The adoption of IFRS offers more simplifications than it is in the case of adopting the Accounting Act. This is due to the fact that IFRS regulate more issues than the Accounting Act and are more detailed. In the case of the Act, the breakdown of simplifications into those resulting from the adoption of small and micro unit status and simplifications for all entities that did not exceed the balance sheet total, revenues and the

number of employees (Chluska, 2016, p. 66) should be taken into account. Examples of possible simplifications under IFRS and the Accounting Act are presented in Table 2.

Table 2: Possible simplifications under IFRS and the Accounting ACT (own elaboration based on Accounting Act, IFRS, Kabalski, 2016, p.11)

IFRS – examples of simplifications	Accounting Act – examples of simplifications
The omission of immaterial costs related to bringing the asset to a useable condition, to the current location and condition or the costs related to the transaction and the measurement of such assets at initial value (IAS 16, IAS 36, IAS 2)	The application of the purchase price to the measurement of materials and goods, while work in progress (up to 3 months) is measured at the direct manufacturing cost or direct materials cost, or it does not need to be measured at all (art. 34, para. 1)
For fixed assets of low value and small differences in useful life for individual components, the renouncement of the separate depreciation of their components (IAS 16)	For fixed assets of low initial unit value, collective depreciation or amortization charges for groups of assets similar in type and purpose or by a single depreciation charge (art. 32, para. 6)
Non-classification of assets of immaterial value held for sale as non-current assets (IFRS 5)	Classification of lease agreements according to the principles set out in tax regulations (art.3 paragraph 6)
Renouncement of the settlement of the so-called cumulated paid absences, if such amounts are not material (IAS 19)	Renouncement of deferred income tax provision and deferred income tax assets, including exemptions (art. 37 paras 10 and 11)
Renouncement of mandatory discounting of receivables, liabilities and provisions, if the difference between the nominal value and the discounted value is minimal	The measurement of financial instruments based exclusively on the Accounting Act
	The calculation of the cost relating to the manufacturing of a product without distinguishing between justified and unjustified portions of fixed indirect costs of manufacturing (art. 28 (4a))

The reference point for the determination of materiality in the audit is, according to ISA 320, the explanation of materiality given in accounting regulations and – in the case of its absence – the explanations regarding materiality presented in Paragraph 2 of this standard. According to this paragraph, information is material if its omission or misstatement may affect economic decisions made by users on the basis of financial statements (ISA 320, para. 2.3). The materiality of information depends on the amount in a particular item or an error – assessed in given circumstances – in the case of the omission or misstatement of this item. The determination of materiality involves defining the limit to which the misstatements disclosed can be corrected without detriment to the quality of the entire financial statements. Materiality is the limit to which the auditor is willing to tolerate financial reporting misstatements without requesting changes (Pfaff, 2018, p. 80).

3. THE DETERMINATION OF THE MATERIALITY THRESHOLD AND ITS SIGNIFICANCE FOR ACCOUNTING AND FINANCIAL AUDIT

In accounting, the materiality threshold is the limit at which events or assets or liabilities may be recognized in a simplified manner or omitted. National and international accounting regulations do not specify the exact amount as the materiality threshold, but contain certain guidelines on how to determine it. These regulations indicate that the level of materiality is to be determined separately by each entity, including its individual financial statements.

The materiality threshold adopted for reporting purposes should be verified in terms of the impact that adopted simplifications had on users' decisions. The assessment of the materiality threshold by users of financial statement information will be a subjective judgment (Kabalski, 2016, pp. 13-14). The level of materiality adopted in accounting and stipulated in the accounting policy may be the starting point for the statutory auditor in setting the materiality threshold for the purposes of financial statements audit. The materiality threshold is the limit at which the auditor is willing to tolerate financial reporting misstatements without requesting changes (Pfaff, 2018, p. 82). The determination of the level of materiality, according to ISA, involves the auditor formulating the opinion about the size and nature of misstatements that will be considered material. The statutory auditor defines materiality based on his professional judgment and perception of the needs of financial statements users in the area of financial information. This approach means that the auditor may consider reasonable that users:

- a) have sufficient knowledge in the field of business and accounting as well as they are willing to become acquainted with the information presented in the financial statements,
- b) understand that financial statements are prepared, presented and examined with the level of materiality taken into account,
- c) realize the inevitable uncertainty of measurement of amounts determined based on estimates, judgments and forecasts of future events, and, finally,
- d) make rational economic decisions based on the information provided in the financial statements (ISA 320, para. 4).

The auditor applies the concept of materiality:

- a) when planning and conducting the audit,
- b) after the audit (Pfaff, 2008, p. 138).

When planning the audit, the auditor determines overall materiality, i.e. the materiality of the financial statements in their entirety. If planning takes place before the balance sheet date (or after that date but before the financial statements are prepared), the financial statements for which materiality is determined do not exist, therefore, while determining overall materiality, the auditor takes into account:

- a) the already acquired knowledge about the entity under audit,
- b) the financial statements from previous years and for interim periods,
- c) experience gained through auditing the financial statements of similar entities,
- d) trust or lack thereof in the entity's management,
- e) the appraisal of the quality of the entity's financial and accounting units (Pfaff, 2018, p. 81).

Overall materiality assessed during the planning stage of the audit is verified by the statutory auditor during subsequent steps. At the end of the audit, the auditor reassesses the materiality of the identified misstatements. Based on the data in the final version of the financial statements, including adjustments made by the entity and proposed by the auditor as a result of the financial audit, the auditor reassess the level of materiality. The statutory auditor separately determines overall materiality and performance materiality. Overall materiality (Io) is determined for the financial statements in their entirety. Performance materiality (Iw) is determined for individual balances or groups of operations. This materiality defines the maximum collective error that the auditor can accept, recognizing that – despite the error – the audit result allowed for the achievement of the audit objective, and the reliability of the entity's statements was not undermined. Two methods can be used to determine performance materiality:

- a) the proportional distribution of materiality,
- b) the distribution of materiality according to the square-root formula.

The proportional distribution of materiality assumes its simple division into component materialities, concerning individual items of the financial statements, according to the calculated percentage ratios. The method is simple to use, but it does not take into account the nature and weight of the given item or the opinion of the statutory auditor. The calculation of performance materiality for individual assets and liabilities in the balance sheet can be conducted using the following formula:

$$I_c = I_o \times \sqrt{\frac{\text{total assets or liabilities}}{\text{balance sheet total}}}$$

$$I_c = I_o \sqrt{\frac{\text{profit and loss account item}}{\text{net revenues of goods and materials}}}$$

where:

I_c - component materiality

I_o - overall materiality

The calculation of component materiality with the use of the above formulae will allow the auditor to identify the items that can be omitted in the auditing process. The auditor should verify the calculation results using professional judgment and the knowledge of the audited entity. Another method of estimating the materiality threshold is the method based on the comparison of the values of particular items in the financial statements with the materiality threshold, with the simultaneous determination of a given item as being material or immaterial. The selection of the basis for calculating the materiality threshold depends on the professional judgment of the statutory auditor. There are no general or specific guidelines for the calculation base. International audit practice, however, has developed criteria that the auditor can use when determining the materiality threshold. The most common indicators, broken down by country, are presented in Table 3.

Table 3: Criteria of materialit (Pfaff, 2018, p.82 Kabalski, 2016, p.11)

Country	Type of indicator	Value
USA	Gross financial result on continued operation	5%
	Balance sheet total	5%
UK	Net earnings	10%
	EBIT	5%
	Revenue	0,5-1%
	Balance sheet total	1-2%
Norway	EBIT	5%
	Total assets	0,5%
	Equity	1%
	Sales	0,5%
China	Financial result	5%
Other	EBIT	5-10%
	Balance sheet total	0,5-1%
	Sale of goods	0,5-1%
	Equity	1-2%

The audit of the financial statements involves the risk that the statutory auditor may reduce by setting additional materiality thresholds, lower than the threshold of overall materiality, the exceeding of which should trigger the professional skepticism of the statutory auditor.

Value-based materiality refers to financial misstatements, it does not refer to non-financial misstatements. The estimated level of materiality helps to determine the scope of auditing procedures that need to be conducted and provides a reference point for assessing the implications of misstatements identified by the auditor and their impact on the reliability of the financial statements (Pfaff, 2018, pp. 83-84). The selection of the basis for calculating the materiality threshold is part of the audit of the financial statements. The materiality threshold set by the auditor depends on the risk that he assesses. There is a relationship between materiality and the risk of the audit. Materiality is inversely proportional to the level of risk of the audit. The higher the risk of the audit, the lower the level of materiality (Tyrańska, 2016, p.45).

4. CONCLUSION

The principle of materiality, one of the accounting principles, is conducive to the achievement of the objectives of accounting while reducing its costs. An entity guided by this principle can use simplifications provided these do not adversely affect the true and fair picture of its property and financial standing as well as financial result. When conducting accounting, economic entities applying the principle of materiality should take into account the expectations of external users of financial statements while maintaining the usefulness of the financial statements. Information, if immaterial, is not useful for users of financial statements and therefore can be omitted. The level of materiality is defined by the materiality threshold, which should be specified by the entity under the accepted accounting principles (policy). Materiality also plays an important role in the audit of financial statements. The correct determination of the level of materiality allows users to distinguish between significant and non-significant irregularities, which affects the correctness of the audit result. Accounting and financial audit regulations do not specify the materiality threshold and only contain some guidelines on how to determine it. The guidelines vary depending on the country or professional organizations that give exemplary thresholds. Ultimately, in accounting, the responsibility for the proper application of the principle of materiality and the determination of the materiality threshold lies with the entity's management, while in auditing – with the statutory auditor drawing on his experience and professional judgment

LITERATURE:

1. Chluska J. (2016). *Uproszczenia rachunkowości jednostek mikro i małych- szanse i zagrożenia*. Zeszyty Naukowe Uniwersytetu Ekonomicznego w Katowicach nr 268, Studia Ekonomiczne. Katowice: Wydawnictwo Uniwersytetu Ekonomicznego w Katowicach
2. Dobija, M. (red.) (2005). *Teoria rachunkowości w zarysie*. Kraków: Wydawnictwo Akademii Ekonomicznej w Krakowie.
3. Dyrektywa UE w sprawie ujawniania danych niefinansowych i informacji na temat różnorodności. (oryginalny tytuł: EU Directive on disclosure of non-financial and diversity information). Stanowisko FEE. (2016), Centrum Edukacji KibR, http://www.fe.be/images/publications/Corporate_Reporting/FEE_position_paper_EU_NFI_Directive_final.pdf
4. Hendriksen, M.F. van Breda (2000). *Teoria rachunkowości*. Warszawa: PWN
5. Kabalski P. (2016). *Istotność w rachunkowości*. Rachunkowość nr 8
6. Kumor I. (2014). *Nadrzędne zasady rachunkowości a wartość bilansowa przedsiębiorst.* Zeszyty Naukowe Uniwersytetu Szczecińskiego nr 804, Finanse, Rynki Finansowe, Ubezpieczenia nr 67
7. KSRF 320, *Istotność przy planowaniu i przeprowadzaniu badania*, <https://www.pibr.org.pl/assts/file/507>, KRBR-uchwała-2783-52-2015-KSRF-320.pdf (dostęp: 02.04.2018)

8. Międzynarodowe Standardy Sprawozdań Finansowych. (2016). Warszawa: Stowarzyszenie Księgowych w Polsce.
9. Międzynarodowe Standardy Sprawozdawczości Finansowej. *Założenia koncepcyjne sprawozdawczości finansowej*. (2016). Warszawa: Stowarzyszenie Księgowych w Polsce.
10. Pfaff J. (2008). *Wpływ rewizji finansowej na wiarygodność sprawozdania finansowego*. Katowice: Prace Naukowe, Wydawnictwo Akademii Ekonomicznej im. K. Adamieckiego w Katowicach
11. Pfaff J. (2018). *Rewizja finansowa*. Katowice: Wydawnictwo Uniwersytetu Ekonomicznego w Katowicach.
12. Śnieżek E., Wiatr M. (2016). *Dobrowolne ujawnienia informacji jako kierunek doskonalenia sprawozdawczości finansowej*. Zeszyty Naukowe Uniwersytetu Ekonomicznego w Katowicach nr 268, Studia Ekonomiczne. Katowice: Wydawnictwo Uniwersytetu Ekonomicznego w Katowicach
13. Tyrańska M. (2016). *Wybrane metody audytu sprawozdań finansowych*, Jurnal of Modern Management Process 1 (1)/journalmmp.com (dostęp: 04.04.2018)
14. Ustawa z dnia 29 września 1994 r. *o rachunkowości*, Dz. U. z 2018 r., poz.395 z późn. zm.

THE INFLUENCE OF PRODUCTION SUBCONTRACTING FORMS ON THE DEVELOPMENT OF SMALL BUSINESS FIRMS IN NIGERIA

Nwokocha Victor Chukwunweike

*Department of Geography, University of Nigeria, Nigeria
victor.nwokocha@unn.edu.ng*

ABSTRACT

Given the numerous challenges hampering the growth and development of small business firms (SBFs) in Nigeria, this paper examines the various ways through which production subcontracting have influenced the development of SBFs in Nigeria. While the paper adopted a number of methods comprising of field observations, reference to relevant literature, and questionnaire survey of 96 SBFs, a regression analysis was used to ascertain the relationship between production subcontracting forms and SBFs development. In line with the literature, this study identified three production subcontracting forms- specialised subcontracting, supplier subcontracting and capacity subcontracting. The study evaluated the relationship between production subcontracting forms and SBFs development- cost reduction, risk reduction, access to resources and knowledge. The paper found that two production subcontracting forms-capacity subcontracting and specialised subcontracting have positive relationship with cost reduction and risk reduction while there was no relationship between these production subcontracting types and resource accessibility as well as knowledge accessibility. This paper concludes by suggesting that constraints to SBFs development in Nigeria can be improved upon by constant de-centralization of production activities by SBFs through the various productions production subcontracting forms analysed in this paper.

Keywords: *Development, Nigeria, Small and Medium Enterprises, Subcontracting*

1. INTRODUCTION

Access to resources and the ability to reduce cost and risk in business is vital for the survival, growth and sustenance of any firm. This however is relatively difficult to achieve by individual firms such as small and medium scale enterprises (SBFs) which are constrained by a number of physical and socio-economic challenges. Some of these challenges are high interest rates, unstable foreign exchange market, infrastructural inadequacies, poor market accessibility; uncompetitive products etc. Considering these challenges SBFs in the developing countries such as Nigeria, find it difficult to withstand and carry out their production activities. (Kafigi, 2015). This is because, they are expected to use their own resources to meet research and development costs, production and marketing cost as well as overhead costs incurred from providing alternative infrastructure such as power supply. These costs cannot be met by SBFs who are constrained with - limited access to finance, market, technology, information, and inadequate working premises (Okon and Edet, 2016; Adoyi, Agu, Oji and Alapa, 2015; Kafigi 2015; Nwokocha, Madu, Ocheje and Olerum 2015). In Nigeria, the adoption of various economic reform programmes have been a decisive switch from large scale industrial project to small and medium scale enterprises (SBFs) with immense potentials for developing domestic linkages for rapid, sustainable industrial development and employment generation (Afolabi, 2013; Aremu and Adeyemi, 2011; Donati and Sarno, 2015). These programmes -Small and Medium Industry Equities Investment Scheme –SMIEIS, National Economic and Empowerment Development Strategy- NEEDS etc as laudable as they, have failed to address the competitiveness and development of SBFs operating in the manufacturing sector of the country. This is because most of these policies and programmes were not formulated and guided by the operational characteristics of the SBFs operating in Nigeria and therefore lacked the necessary framework to address the challenges of the sector (Nwokocha, Madu, Ocheje,

Olerum, and Nwosu, 2015a). However, given the potentials of SBFs in achieving the economic growth and development, job creation and utilization of local resources, it has become important for these challenges constraining the development of this sector to be addressed. One of the ways identified by this paper to address these challenges is through production subcontracting. Production subcontracting is the de-centralization of production processes among firms. It is a work contract that seeks to contract certain types of work to other companies while the contractor concentrates on its core competence. (Ayayi, 2005; Ogbari, Ajagbe, Isiavwe and Ade-Turton, 2015; Willian, Davis and Chinguno, 2015; Chan, Pun and Selden, 2015). The adoption of this processes improves the competitiveness of companies, especially in complex and turbulent environments, bridge the gap between the firm's present resources and its expected future requirements, as well as engendering transaction cost and business risk reduction (Shankar, 2016). A review of empirical studies suggests that production subcontracting strategies can be utilized in three forms (Kafigi, 2015; Kongmanila and Takahasib, 2009). They are capacity subcontracting, specialised production subcontracting and supplier subcontracting. While capacity production subcontracting is structured to meet fluctuations in demand, which usually create excess capacity, unfilled orders and long delivery times, supplier subcontracting is structure to enable SBFs subcontract or outsources production functions in order to concentrate on their core activities and specialised subcontracting is structured to enable firms/SBFs gain access to processes, machineries, skills, technical-know-how which are not easily available within the firm or available in the open market. The utilization of these various forms of production subcontracting by a firm ensures de-centralization of non core activities, increase cooperation with other SBFs, resource accessibility, knowledge accessibility, cost and risk reductions. This paper proposes therefore that the development of SBFs in Nigeria can be found in the ability of firms to engage in the de-centralization of non-core activities, increasing co-operations with other firms in order to reduce risk, production costs as well as gaining access to resources and knowledge outside their own boundaries. Consequently, the aim of this paper is to answer the following question: Does the development of SBFs depend on the production subcontracting forms- capacity subcontracting, specialised production subcontracting and supplier production subcontracting formed by partnering SBFs? In this paper, we define "SME development" as the ability to achieve cost reduction, risk reduction, resource and knowledge accessibility.

2. CONCEPTUAL FRAMEWORK

Small business firms are manufacturing, processing or service enterprises, that create independence, self-reliance, expectation of income for owners, employment opportunities, utilization of local resources, economic development etc (Obioma, 2017). The development of SBFs is vital because they play critical role in economic development of nations and they serve as the hub and vitality for economic development of any society. They are labour intensive, capital saving and capable of creating new jobs for the unemployed (Agwu and Emeti, 2014). For instance, SBFs have been found to contribute not less than 70% to the GDP of the Ghana and therefore have significant impact on economic growth, income and employment (Peprah, Mensah, and Akosah 2016). In India, SBFs have contributed appreciably to the growth and performance of the Indian economy by the creation of livelihood opportunities to millions of people, enhancing the export potential of the country and in increasing the overall economic growth of the country (Gupta and Chaturvedi, 2017), while in Europe, they have become a major source of entrepreneurial skills, innovation and employment and have provided about 75 million jobs in the region. (European Commission, 2008). In Nigeria, evidence has shown that small business firms have underperformed and have not made significant contribution to the nation's economic growth and development (Ololube and Uzorka, 2008; Muritala, Awolaja and Bako, 2012; Agwu and Emeti, 2014; Ebitu, Basil and Ufot, 2017).

The key issues affecting the SBFs in Nigeria can be grouped into four namely; unfriendly business environment (infrastructural inadequacies, unstable foreign exchange market, high risk of doing business etc), poor funding (high interest rate, inaccessible collateral requirements etc), low managerial skills and lack of access to modern technology (Muritala, Awolaja and Bako 2012; Agwu and Emeti, 2014; Ebitu, Basil and Ufot, 2017). Considering these challenges, most SBFs in the developing countries such as Nigeria, find it difficult to withstand and carry out production activities alone. (Donati and Sarmo, 2015; Kafigi, 2015). This is because, they are expected to use their own resources to meet research and development costs, production and marketing cost as well as overhead costs incurred from providing alternative infrastructure such as power supply. For SBFs to address these operational constraints, the adoption of production subcontracting strategy becomes vital and key for the sector. A well structured production subcontracting arrangement gives firms the opportunity to access resources (Baily, Masson and Raeside, 2002; Kumar and Subrahmanya, 2004; Jenkin, Alkhalkatshi, Roberts and Gardiners 2007), knowledge (Asheim and Coenen, 2005; Wang and Nicholas, 2005; Smyth and Duryan, 2016), cost reduction (Chang and Gotcher, 2007; Williamson, 2008; Memili, Chrisman, Chua, Chang, and Kellermanns, 2011) , risk reduction (Asanuma, 1992; Yang, Zou and Wang, 2016). In the area of resources accessibility, production subcontracting can be used to access new technology, significant technological information, and opportunities for technological transfer (Elmuti & Kathawala, 2001; Hagedoorn & Letterie & Palm, 2011; Elmuti & Abebe, & Nicolosi, 2005). It can also be used to enhance production process, access the services of skilled employees, factory building, machinery, efficient procedures and organizational processes, capital, business contacts, knowledge, information, (Alarapa, 2007; Ono, 2007) as well as helping SME to achieve competitive advantages (Das & Teng, 2000). Similarly, production subcontracting has been attributed to cost reduction. Following Coase's (1937) seminal work, activities would be subcontracted where the perceived costs of using the market were less than that of undertaking the activity in house. From this point of view, the decision to subcontract constitutes primarily a trade off between the cost and benefits associated with each alternative (Coase, 1937; Williamson, 1975; 1979; 1984; Scott, 1988; Storper and Scott, 1990). Cost reduction can be achieved through production subcontracting in three ways. These include contracting out parts of a production task to a lower wage producer (supplier subcontracting), contracting out production tasks during peak of demand (capacity subcontracting) and specialising on a firm's core competence while subcontracting out peripheral tasks to other firms (specialised subcontracting) (Girma and Gorg, 2004). Risk reduction can be fostered by SBFs through subcontracting. De-centralisation of production processes or task means that firms give out those aspects of their production where they lack competence to other firms. By so doing, they are able to eliminate the risks associated with taking up such tasks in house. When an industry chooses to focus on the core activity, it outsources the other activities that previously were conducted in-house in order to minimise risks and to build long-term trust relations with future supplier or customer either financially, legally or proprietary (Ragnarson, 2000). These risks once identified can be mitigated by various forms of subcontracting, such as capacity, specialised and supplier subcontracting. Production subcontracting also helps SBFs to acquire specialized and crucial knowledge from other organizations without foregoing their own skills and capacities (Yavirach, 2013). This reduces the cost of information search, permits rapid organizational learning, and increases the capacities of the cooperating firms. This most times is associated with projects that require lots of technical information. The main objective of this paper is to prove that production subcontracting forms-capacity, specialised and supplier subcontracting can be used to achieve SME development through -cost reduction, risk reduction, access to resources and access to resources.

3. METHODOLOGY

The study adopted a number of methods comprising of field observations, reference to relevant literature, and questionnaire survey of 169 SBFs.

3.1. Sample Size

This paper purposely selected for the study 169 SBFs out of 200 found in the industrial directory of the area. The 169 SBF were selected on the basis of participation and willingness to supply information for the research. Questionnaires were administered to the 169 managers using a direct delivery technique. This method was adopted not only to get to the targeted population but also to collect the relevant information needed for this paper. Sampling strategies and sampling design were constrained by the practical circumstances surrounding the targeted population, time and cost. A pilot test on 20 SBFs helped to remove ambiguities and improve the instrument. Regression analysis was used to ascertain the relationship between production subcontracting typologies and SBFs development. While production subcontracting typologies were used as the independent variable, SBFs development was used as the dependent variables in the paper. This was to verify the impact of the production subcontracting types on cost and risk reduction as well as resource and knowledge accessibility. Simple statistics of mean and standard deviation was used to determine the relevance and usefulness of production subcontracting typologies to SBFs.

4. RESULT

4.1. Production subcontracting forms and sbfs development

In line with the literature, three types of production subcontracting were adopted by this study. They are supplier subcontracting, specialises subcontracting and capacity subcontracting. Using simple descriptive statistics of mean and standard deviation, the relevance and usefulness of the production subcontracting typologies- specialised, capacity and supplier subcontracting in cost reduction, risk reduction, resources and knowledge accessibility by SBFs were analysed. The result of the analysis showed that supplier subcontracting was used by the SBFs to achieve cost reduction, risk reduction and access to resources with mean and standard deviation values of $M=2.15$ $S=0.36$, $M=2.36$ $S=0.78$, $M=2.15$ $S=0.46$ as was shown in table 1.

Table 1: Descriptive statistics of Supplier subcontracting

Supplier subcontracting	N	Minimum	Maximum	Mean	Std. Deviation
Cost Reduction	96	2.00	4.00	2.15	0.46
Risk Reduction	96	1.00	4.00	2.36	0.78
Access to Resources	96	2.00	3.00	2.15	0.36
Access to Knowledge	96	1.00	1.00	0.23	0.43
Valid N (list wise)	96				

Author's computation

This result shows that SBFs in this paper make use of supplier subcontracting in order to achieve cost reduction, risk reduction and access to resources. Similarly, the analysis of specialised subcontracting showed that this type of subcontracting provides SBFs with the opportunities of cost reduction, risk reduction and access to resources as was indicated in table 2.

Table 2: Descriptive statistics of Specialised Subcontracting

Specialised Subcontracting	N	Minimum	Maximum	Mean	Std. Deviation
	Statistic	Statistic	Statistic	Statistic	Statistic
Cost Reduction	96	1.00	4.00	2.64	0.89
Risk Reduction	96	1.00	5.00	3.13	1.25
Access to Resources	96	2.00	5.00	3.22	1.25
Access to Knowledge	96	1.00	2.00	0.54	0.22
Valid N (list wise)	96				

Author's Computation

The result also shows that specialised subcontracting is highest with access to resources and risk reduction. This from our observation shows that SBFs in the study area largely depended on each other to access skills and machineries which are not accessible within the enterprise. This helps these enterprises to reduce the risk burden of developing additional capacity with which to address their shortfalls. However, a standard deviation value of 1.25 equally shows that other factors other than risk reduction and access to resources could as well explain the relationship between specialised production subcontracting and cost reduction as well as access to resources. The use of specialised subcontracting was observed mostly with table and sachet water SBFs. These SBFs lack specialities in the areas of sachet and bottle manufacturing and therefore rely on other SBFs in the plastic sector for the production of these items. Furthermore, the analysis of capacity subcontracting shows that SBFs can achieve cost reduction, risk reduction and access to resources using this type of subcontracting as was captured in table 3.

Table 3: Descriptive statistics of Capacity Subcontracting

	N	Minimum	Maximum	Mean	Std. Deviation
Capacity Subcontracting	Statistic	Statistic	Statistic	Statistic	Statistic
Cost Reduction	96	1.00	5.00	2.46	0.99
Risk Reduction	96	1.00	5.00	2.50	0.99
Access to Resources	96	1.00	3.00	2.16	0.53
Access to Knowledge	96	1.00	2.00	0.73	0.54
Valid N (list wise)	96				

Author's Computation

The result equally showed that capacity subcontracting play a more significant role in risk reduction to the other variables. This was observed with some of the SBFs which subcontracted parts of their production tasks to other SBFs in order to meet excess capacity, unfilled orders and long delivery times. These from our investigation helped the SBFs share and reduce the risks of creating additional capacities to perform the tasks in-house. This was mostly observed with SBFs in metal, iron and fabrication as well as those in printing, publishing and paper processing SBFs. These SBFs subcontract tasks which cannot be accommodated within their enterprises to other SBFs rather than increasing their labour force or other forms of capacities to carry out such tasks in- house.

This according to the management of these SBFs helps them to maintain a stable production budget since most of these tasks or demand fluctuates and largely unstable. However knowledge accessibility was found not to be significant with the three forms of subcontracting analysed in this paper. A mean value of less than 1 show that the de-centralization of production tasks by SBFs does not give them access to new knowledge. This is because all the tasks contracted out by the SBFs take place outside of their domain and therefore does not give them the opportunity to learn or acquire any new knowledge. This findings collaborates the theoretical foundation of this paper as SBFs engage in subcontracting processes to reduce cost, risk and to access knowledge and resources. Furthermore, in order to establish the relationship between production subcontracting typologies and SBFs development, a regression analysis was deployed in the paper. The result of the analysis shows that there is a significant relationship between capacity subcontracting and cost reduction and risk reduction (0.01 and 0.05) while there was not significant relationship between capacity subcontracting, resource accessibility and knowledge accessibility (0.43 and 0.58) as shown in table 4.

Table 4: Summary of Output for Capacity subcontracting and SBFs Development

Capacity Subcontracting	Adjusted R²	P. Value	Significant F
Variables			
Cost Reduction	0.02	0.01	0.01
Risk Reduction	0.03	0.05	0.05
Resource Accessibility	-0.01	0.43	0.43
Knowledge Accessibility	-0.01	0.58	0.58

Author's Computation

This result shows that capacity subcontracting helps SBFs to reduce both cost and risk of production. By externalising production, capacity subcontracting helps SBFs to concentrate on their area of competence while relying on others firms for the areas where they fell short in the production process. Capacity subcontracting however gives SBFs access to neither resources nor knowledge. This is because SBFs engaged in this arrangement use their resources at both ends to carry out their task. This structure unlike other linkage types such as strategic alliance gives no room for resource and knowledge accessibility to SBFs. Similarly, the result equally showed that there is a significant relationship between specialised subcontracting, cost reductions, risk reduction and resource accessibility (0.02 and 0.01) while there was no significant relationship between specialised subcontracting, resource and knowledge accessibility (0.55, 0.95) as was shown in table 5.

Table 5: Summary of Output for Specialised Production subcontracting and SBFs Sustainability

Specialised Subcontracting	Adjusted R²	P. Value	Significant F
Variables			
Cost Reduction	0.05	0.02	0.02
Risk Reduction	0.06	0.01	0.01
Resource Accessibility	-0.08	0.55	0.55
Knowledge Accessibility	-0.01	0.95	0.95

Author's Computation

The results of this analysis have shown that specialised subcontracting helps SBFs to reduce the cost and risk of production while it has no impact on resource and knowledge accessibility. With specialised subcontracting, SBFs contracts out productions activities requiring specialised skills, process and machineries to other SBFs with such capacity while retaining their core competence in-house. This helps the SBFs to reduce the cost and risk involved in pursuing such production in-house. This arrangement does not give SBFs access to resources and knowledge since the production subcontracting arrangement between the SBFs are pursued with individual resources and on an independent basis. The regression analysis also showed that there is no significant relationship between supplier subcontracting, cost reduction, risk reduction, resource and knowledge accessibility (0.51, 0.10, 0.93 and 0.80) as was indicated in tables 6.

Table 6: Summary of Output for Supplier subcontracting and SBFs Sustainability

Supplier Subcontracting	Adjusted R²	P. Value	Significant F
Variables			
Cost Reduction	-0.01	0.51	0.51
Risk Reduction	0.03	0.10	0.10
Resource Accessibility	-0.01	0.93	0.93
Knowledge Accessibility	-0.01	0.80	0.80

Author's Computation

This from the analysis shows that SBFs cannot achieve sustainability through supplier subcontracting. In other words, SBFs engaged in supplier subcontracting may not achieve cost reduction, risk reduction knowledge and resource accessibility. This however can be explained by other factors which currently are not within the scope of this paper.

5. CONCLUSION

This study set out to establish an empirically plausible relationship between production subcontracting forms and the sustainability of SBFs in Nigeria. The paper found that two production subcontracting typologies-capacity subcontracting and specialised production subcontracting have positive relationship with cost reduction and risk reduction while there was no relationship between these production subcontracting types and resource and knowledge accessibility. This paper also found that there was no significant relationship between supplier subcontracting, cost reduction, risk reduction, resource and knowledge accessibility. Thus, this paper concludes by suggesting that high cost of production and ever increasing production risks which are the common features of SBFs in Nigeria can be mitigated through the externalization of production activities by SBFs in the country. The externalization of these activities can be achieved through the various production subcontracting forms analysed in this paper. This will not only ensure the sustainability of these SBFs, it will equally guarantee job creation, growth and development of the economy which as of today is on a free fall. However, considering the dearth in academic literature on this area of research, it is important that further research be carried out in this area more especially in the area of firm performance and production subcontracting forms as well as supplier subcontracting and SBFs development. The results/ findings of this research will help bring to the academic domain the comprehensive impact of production subcontracting typologies on firms.

LITERATURE:

1. Adoyi, J., Agu, O. A., Oji, A.O. & Alapa, I.F. (2015). Small and Medium Scale Enterprises and National Development. *European Journal of Business and Management* 7 (13): pp. 123-137
2. Afolabi, M O. (2013): "Growth effect of Small and Medium Enterprises (SBFs) Financing in Nigeria". *Journal of African Macroeconomic Review* 3(1): Pp 25-32
3. Agwu, M.O & Emeti, C.I (2014). Issues, Challenges and Prospects of Small and Medium
4. Scale Enterprises (SBFs) in Port-Harcourt City, Nigeria. *European Journal of Sustainable Development*, (3):1, pp. 101-114
5. Alarape, A.A. (2007). Towards a Framework for the Development of Effective Production subcontracting and Network relations among Small, Medium and Large Industries in Nigeria, *Journal of Small Business and Entrepreneurship*, 20 (2): Pp 101-116
6. Asanuma, B (1992). Risk absorption in Japanese subcontracting: A micro econometric study of the automobile industry. *Journal of the Japanese and International Economics* 6: (1), pp 1-29
7. Asheim, B.T& Coenen, L (2005).Knowledge bases and regional innovation systems: Comparing Nordic clusters. *Research Policy*, 34: (8).pp 1173-1190
8. Bailey W., Meason R., & Raeside, R. (2002). Outsourcing in Edinburgh and Lothians. *European Journal of Purchasing and Supply Management* 8: (1) pp.83-95.
9. Barney, J.B & Clark, D.N. (2007). *Resource-Based Theory: Creating and Sustaining Competitive Advantage*. New York: Oxford University Press
10. Ceglie G. & Stancher A (2009) "The industrial district model in the development strategy of international organizations: the example of UNIDO", forthcoming in Becattini (ed.) *Handbook of Industrial Districts*.
11. Chan, J, Pun, N & Selden, M. (2015). Apple's iPad City: Production subcontracting Exploitation to China." In *Handbook of the International Political Economy of Production*, Cheltenham, UK: Edward Elgar, pp 76-97.
12. Chang, K.H. & Gotcher, D. F. (2007). Safeguarding investments and creation of transaction value in asymmetric international production subcontracting relationships: The role of relationship learning and relational capital. *Journal of World Business*, 42: (4) pp 477-488
13. Christophe M. & Franck G. (2013). Nuclear Decommissioning and Organisational Reliability: Involving Subcontractors in Collective Action. *Decommissioning Challenges: An Industrial Reality and Prospects*, 5th International Conference, Apr 2013, Avignon, France, p. 9.
14. Ding, Q., Akoorie, M.E.M. & Pavlovich, K. (2009). A Critical Review of Three Theoretical Approaches on Knowledge Transfer in Cooperative Alliance. *International Journal of Business and Management*, Vol. 4(1) pp 47-55
15. Donati, C., & Sarno, D. (2015) Are firms in "backward" areas of developed regions more financially constrained? The case of Italian SBFs. *Industrial and Corporate Change*, 24(6),pp 1353-1375
16. Dunning, J.H. (2015). *Reappraising the Eclectic Paradigm in an Age of Alliance Capitalism. A Framework for Synthesizing and Comparing Theories of International Business from Different Disciplines or Perspectives* UK: Palgrave Macmillian, pp. 111-142
17. European Commission (2008). *Commission Staff Working Document. European Code of Best Practices Facilitating Access by SBFs to Public Procurement Contracts*. (SEC(2008)2193).
18. Gakure, R. W., Kimemia, P. N., & Waititu, G. A. (2014). Influence of Subcontract Offering on the Performance of Manufacturing Micro and Small Enterprises in Kenya. *IOSR Journal of Humanities and Social Science (IOSR-JHSS)*, 19, Ver. II, 37–46

19. Gomez, H.R, Gharbi, A., Kenne, J.P, Arango, O.M, Selene, E., & Gress, H. (2016) Production control problem integrating overhaul and production subcontracting strategies for a quality deteriorating manufacturing system. *International Production Economics* 171, pp 134-150
20. Grossman, G. M., & Helpman E. (2005). Outsourcing in a global economy. *Review of Economic Studies*, 72, 135–159.
21. Gupta, V.K & Chaturvedi, A (2017). Role and contribution of small scale industries in Economic development in india. *Inspira-Journal of Commerce, Economics & Computer Science (JCECS)* (03) : 01, January - March, 2017, pp. 41-48
22. Hajej, Z., Rezg, N., & Gharbi, A. (2014). Forecasting and maintenance problem underproduction subcontracting constraint with transportation delay. *International Journal of Production Research*, 52, 6695–6716
23. Hagedoorn, J., Letterie, W., & Palm, F. (2011) The Information Value of R&D Alliances: The Preference for Local or Distant Ties. *Strategic Organization*, IX (4), 283-309
24. Holl, A. (2007). Production production subcontracting and location. Madrid: FEDEA Foundation for Applied Economics Studies.
25. Hu, Z., Zheng, J., & Wang, J. (2011). Impact of industrial linkages on firm performance in Chinese development zones, Yangtze River Delta, Jiangsu Province, China. *The Chinese Economy*, 44, 78–105.
26. Ikejiofor, I.G. (2012): Characteristics and Linkages of small and medium scale industries in Enugu State, Nigeria. Unpublished M.Sc Thesis, Dept of Geography, University of Nigeria, Nsukka.
27. Jenkins. B., Alkhalkatsi, A., Roberts, B. & Gardiner, A. (2007). Business Linkages: lessons, opportunities and challenges. *International Finance Corporation Report*
28. Kafigi, J. (2015) Strategic Alliance Forms and Survival Chances among Medium-Sized Manufacturing Firms in Tanzania, *Journal Competitiveness* Vol. 7: 2, pp. 38 – 47
29. Kimura, F. (2001): Fragmentation, internalization, and inter-firm linkages: Evidence from the micro data of Japanese manufacturing firms, in *Global production and trade in East Asia*, (Eds.) L.K. Cheng and H. Kierzkowski, Kluwer Academic Publishers, Boston
30. Knoke, D. (2009). Playing Well Together: Creating Corporate Social Capital in Strategic Alliance Networks. *American Behavioral Scientist*, Vol.52:12 Pp 225-236
31. Kotturu, C.W & Mahanty, B. (2015). Production subcontracting dimensions in the small and medium enterprises: Study of auto components’ manufacturing industry in India. *Journal of Engineering Manufacture* 230 (2)
32. Kongmanilaa, .X. & Takahashib, .Y. (2009): “Determinants of Production subcontracting and Firm Performance in Lao PDR: Evidence from a Garment Industry Cluster”. *Asia Pacific Management Review* 15(1) (2010) pp 97-112
33. Kulemeka, P.J. Kululanga, G & Morton, D (2015). Critical Factors Inhibiting Performance of Small- and Medium-Scale Contractors in Sub-Saharan Region: A Case for Malawi. *Journal of Construction Engineering*, 2015(2015), pp 17 -24
34. Kumar, R. S., & Subrahmanya, B. (2007). Production subcontracting relationships of Indian SBFs with global TNCs: Do SBFs gain, How. *Journal of Asian Economics*, 5, 2–35
35. Marimuthu, M., Arokiasamy, L., & Ismail, M. (2009). Human capital development and its impact on firm performance: Evidence from developmental economics. *The Journal of International Social Research*, (2) 8: pp. 265–272.
36. McGunagle, D.M. (2007). *The Chinese Auto Industry: Taming the Dragon*. VDM Verlag Dr. Muller
37. Memili, E., Chrisman, J. J., Chua, J. H., Chang, E. P. C., Kellermanns, F. W. (2011). The determinants of family firms’ subcontracting: A transaction cost perspective. *Journal of Family Business Strategy*, 2, 1, 26-33.

38. Nwokocha, V. C., Madu, I. A., Ocheje, J. F., Olerum, & V. N.(2015a) Production subcontracting: A strategy for the survival of small and medium scale industries in Nigeria. *Mediterranean Journal of Social Sciences*, Vol.6, Pp 641–651.
39. Nwokocha, V. C., Madu, I. A., Ocheje, J. F., Olerum, V. N., & Nwosu, I. G. (2015b). Production subcontracting: A policy issue for small and medium scale manufacturing industries in Nigeria. *Academic Journal of Interdisciplinary Studies*, 4, 375–385.
40. Nwokocha, V.C. and Madu, I.A. (2015). Influence of production subcontracting constraints on the performance of manufacturing industries in Nigeria. *Production and Manufacturing Research* (3):1, pp.343-354
41. Obioma O (2017) Aligning Small and Medium Enterprises for Competitiveness in Nigeria: The Role of Strategic Alliance. *Review Public Administration Management*. 5: (1) pp 215-221.
42. Ogbari, E. I. M., Ajagbe, A. M., Isiafwe, T. D. & Ade-Turton, D. (2015). Effects of Production subcontracting on Modern Day Organizations. *Australia Journal of Commerce Study*, 2(2), 1-11.
43. Okatch, B. A., Mukulu, E., & Oyugi, L. (2011). Constraints to production subcontracting arrangements between SBFs and large firms in the motor vehicle industry in Kenya. *International Journal of Business and Social Science*, 2(15), 208–223.
44. Okon, N.B & Edet, T.E (2016). Small and Medium Scale Business Enterprises as a Veritable Tool for Rural Development in Nigeria: Challenges and Prospects. *Journal of Educational Policy and Entrepreneurial Research*, 3(3). Pp 87-97
45. Ongonga J. O., & Abeka E. O. (2011): Networking in the Kenyan informal sector: An attempt to manage the market failures. *African Journal of Business Management* (5) 3: PP. 11323–11334.
46. Ono, Y. (2007): Outsourcing business services and the scope of local markets, *Regional Science and Urban Economics* 37 (2): 220-238
47. Peprah, J.A., Mensah, A.O., & Akosah, B.N (2016). Small and medium sized enterprises (SBFs) accessibility to public procurement: SBFs entity perspective in Ghana. *European Journal of Business and Social Sciences* (4): 11 pp 25 - 40
48. Rambo, C.M (2012). Risk factors influencing the survival of Strategic alliances: evidence from Kenya, *International Journal of Management and Marketing Research* Volume 5 Number 2
49. Santos, J. B., & Brito, L. A. L. (2012). Towards a subjective measurement model for firm performance [Special issue]. *Brazilian Administrative Review*, 9, 95–117.
50. Shankar, P. (2016). Market or Hierarchy? Transaction Cost, Institutional Environment and Foreign collaboration Decision in India. *The Indian Economic Journal* 64 (1 and 2) pp 155-175
51. Smyth, H.J & Duryan, M (2016). Knowledge application in the supply network of infrastructure programme management. In: (Proceedings) COBRA 2016. RICS: London, UK
52. Taymaz, E. & Kiliçaslan, Y. (2004). Determinants of production subcontracting and regional Development: An empirical study on Turkish textile and engineering industries Department of Economics Middle East Technical University Ankara 06531 Turkey
53. Tuan, N. P. & Yoshi, T. (2010). Vertical Linkage and Firm's Performance in Supporting industries in Vietnam. *Asian Journal of Management Research*, 1(1), pp. 1–14.
54. Ubachukwu, N.N (2006). Analysis of the Management of Household Hazardous Waste in Enugu Metropolis. Unpublished M.Sc thesis, University of Nigeria, Nsukka
55. Wang, Y & Nicholas, S (2005). Knowledge Transfer, Knowledge Replication, and Learning in Non-equity Alliances: Operating Contractual Joint Ventures in China *Management International Review* Vol. 45: (1) pp. 99-118

56. Williams, G. Davies, S. & Chinguno, C. (2015). Production subcontracting and Labour Standards: Reassessing the Potential of International Framework Agreements, *British Journal of Industrial Relations*, 53(2), pp. 181-203.
57. Williamson, O.E. (2008). Outsourcing: transaction cost economics and supply chain management. *Journal of Supply Chain Management* 44: (2), pp. 5-16
58. Yang, R.J., Zou, P.K.W. & Wang, J (2016). Modelling stakeholder-associated risk networks in green building projects *International Journal of Project Management* 34 : (1) pp 66-81

GLOBALIZATION PROCESSES AND TRANSNATIONALIZATION OF THE ECONOMY

Olga Vyshnevska

*Doctor of Economics, Professor, Mykolayiv National Agrarian University, Mykolaiv, Ukraine
olganykk@gmail.com*

Olena Kaliuzhna

*PhD in Economics, Doctor of Philosophy, Mykolayiv National Agrarian University,
Mykolayiv, Ukraine
Kalyzna1976@gmail.com*

Irina Banyeva

*Doctor of Economics, Professor, Mykolayiv National Agrarian University, Mykolayiv,
Ukraine
irina-baneva@rambler.ru*

ABSTRACT

Globalization prompted the emergence of global business, which is mainly associated with the process of transnationalization, which requires appropriate adaptation of the global economy. In the context of the relevance of the issue of globalization influence, the authors' research methodology consists in identifying the prerequisites and substantiation of possible approaches to the adaptation of individual states and regions of the world to the intensification of globalization influence, its manifestations, the determination of priorities of state policy in the context of the transnationalization of the world economy, taking into account the protection of national interests, the interests of all participants of the global market. The purpose of the authors' study is to form the authors' position on the essence of globalization processes, their manifestations, their impact on the development of individual countries and regions of the world, the justification of approaches to adaptation to the process of transnationalization of the world economy with the aim of preventing negative trends, leveling risks, ensuring national security of individual states, political, socio-economic, cultural, mental and environmental factors, prioritizing rovedenii long-term state policy based on national interests and the protection of the global market. The consequences of globalization processes, the influence of economies of states and regions of the world, changes in the mentality of the population are determined. The essence of the process of transnationalization, strengthening the influence of international monopolies and the peculiarities of the activities of transnational associations are determined. The influence of the process of transnationalization on the development of the world economy is generalized, advantages and disadvantages in the development of the world economy under the influence of globalization tendencies are determined. The main directions of activity of transnational business are formed, taking into account the interests of participants. The priority of investment opportunities of global business is determined. The main tendencies in dissemination of the influence of the process of transnationalization of the world economy and the consequences in guaranteeing the national security of the countries of the world, individual regions of the world are investigated. It is proved that the policy of the world's states in a globalized environment should have a long-term character and provide the implementation of a set of measures to protect the interests of the national economy, including the increasing influence of the process of transnationalization, the formation of a single global market, which provides appropriate adaptation to change.

Keywords: *globalization, transnationalization, transnational companies, global global processes, global corporations, competitive advantages, investment opportunities*

1. INTRODUCTION

All modern world processes are characterized by the increasing influence of globalization, as a process that transforms the world into a single global system. The globalization of the economy is one of the laws of world development and reflects the interdependence of the economies of different states in the formation of economic space, where the branch structure, the exchange of information and technology, the geography of the distribution of productive forces are determined taking into account the world situation, stages of social reproduction acquire planetary scales. Globalization tendencies of the development of the world economy have a significant impact on individual internal processes and phenomena: socio-economic, political, cultural, mental and environmental. Globalization processes are characterized by a combination of competitive advantages of a particular state at the world level in economic, social and environmental fields. The model of globalization of national economies includes a large national business, medium and small businesses, and multinational companies. At the same time, the weighting factors determine the share of each type of business in the structure of the national economy of the country. Integration processes in the modern world have created such powerful international structures that already influence the fate of any state, often despite the rules of international law and existing international agreements. Globalization is a process that includes the transformation of the spatial organization of the world and its regions, social relations and interactions that are measured by indicators such as: duration, intensity, speed and influence that give rise to intercontinental or interregional flows and structures of activity, interactions and manifestations at socio-economic and political levels. Globalization is essentially a challenge to the economic security of any country that is to some extent integrated with the economic space. Globalization became the most important real characteristic of the world system, an influential force that determines the pace of development of the world community and the world economy. The globalization of economic development arises from the complete interdependence of the components of the world economy, from its unity and integrity, which increases with the wide expansion of the internationalization of production and circulation, and the intensification of integration processes. There is a process of global synthesis of a global scale, which is controversial and multi-faceted, affects the development of the world's economy, individual countries, regions and industries, and society. Globalization led to the emergence of a global business, which is mainly associated with the process of transnationalization. Which approaches of state regulation will allow the economies of the world countries to undergo the process of adaptation? The hypothesis of the scientific research is to identify the preconditions and justification of possible approaches to adaptation of individual states and regions of the world to strengthen the globalization influence, its manifestations, and to determine the priorities of state policy in the conditions of transnationalization of the world economy in order to protect national interests, interests of all participants in the global market. The object of the study is the process of globalization and transnationalization of the world economy, the formation of the global market, their combined impact on the development of individual states and regions of the world, approaches to adaptation in the interests of protecting national interests. The subject of the study is a set of theoretical, methodological and practical principles of the process of globalization and transnationalization of the world economy, their manifestations, influence on the development of individual states and regions of the world, the creation of preconditions for the protection of national interests in the global market. The purpose of the study is to define the position of the authors on the essence of globalization processes, their manifestations, the impact on the development of individual countries and regions of the world, the justification of approaches to adaptation to the process of transnationalization of the world economy in order to prevent negative trends, leveling the risks, guaranteeing the national security of individual states in terms of aggregate political, socio-economic, cultural, mental and environmental factors,

prioritizing long-term public policy review and protection of national interests in the global market.

2. RESEARCH METHODS

The study of globalization processes is associated with a combination of factors that can have a significant impact on the development of the world economy, individual states and regions of the world, industries and society as a whole. In order to study and generalize the globalization impact on the world economy, a wide range of research methods are used, such as: abstract-logical method of research with the aim of substantiating the essence and peculiarities of globalization processes and phenomena, systemic generalization – in order to assess the practical impact of globalization on different world systems and processes. (political, social, economic, cultural, environmental); bibliographic – in order to evaluate various authors' views and generalizations; analysis and synthesis – in order to identify dependencies between globalization processes and phenomena and influence on the world economy. Expect a wide range of international indices and coefficients to assess the adaptation of world economies to globalization processes. One of the generic indices is the KOF Index of Globalization, which is made up of the Swiss Economic Institute. Individual countries of the world are rated by 24 criteria, which are grouped into three main groups of global integration: economic globalization (international trade volume, international business activity, trade flows, international investment, tariff policy, restrictions and taxes on international trade); social globalization (level of cultural integration, percentage of foreign population, international tourism, international personal contacts, volume of telephone traffic, postal items, cross-border remittances, information flows, development of information and communication infrastructure); political globalization (membership of states in international organizations, participation in international missions (including the UN mission), ratification of international multilateral treaties, number of embassies and other foreign missions) (Index...). According to the KOF Index of Globalization, the most globalized countries in 2017 are the Netherlands with the index of 92.84, Ireland (92.15), Belgium (91.75), Austria (90.05), Switzerland (88.79). According to the KOF Index of Globalization, the world's least-globalized states are Equatorial Guinea with an index of 26.16, Eritrea (25.07), and Solomon Islands (23.98). The study used information from 193 countries of the world, the difference between the maximum and minimum values of the index is 68.86 units, which confirms the complexity of adaptation of the countries of the world to globalization changes, different input conditions and approaches in the development of economies of individual countries of the world. Ukraine ranks 45th in terms of globalization, with an index of 70.24. In addition to the complexity of the process of adaptation of the economies of individual states and regions of the world, a significant factor is the building-up of capacities of transnational companies (hereinafter referred to as TNCs). The assessment of the activities of TNCs proves that they provide almost 50.0% of the world's industrial production; TNCs account for more than 70.0% of world trade. Thus, the relevance of the study is due to the fact that globalization processes have a comprehensive impact on the development of the world economy, the economies of individual states and regions of the world, which requires the prevention of negative trends, the leveling of risks in order to guarantee the security of the world, national security of individual states in terms of the totality political, socio-economic, cultural, mental and environmental factors. The expansion of the scope of transnational business has a significant impact on the level of security, as most companies are oriented mainly to obtain their own economic benefits, which can encourage social tensions in the recipient state's society. The complexity of the manifestations of globalization processes, their impact on the world economy, the economy of individual states and regions of the world encourages the spread of research, due to the political and socio-economic processes, especially the mentality of the population.

The works of many scientists are devoted to the research on the essence and peculiarities of the process of globalization, the transnationalization of the world economy, their interrelation with political and socio-economic systems, among which: O. A. Volodymyrova (2010), V.I. Vlasova (2012), V.G. Voronkova, D. Ghed (2004), P.Gerst (2002), E. Giddens (2004), L.O.Zelenova (2010), E.G. Kochetova (2010), E.I. Stepanova (2010), Ya. Piterze (2008), R. Robertson (2008), R. Skase (2007), J. Soros, J. Stiglitz, E. Toffler. Historical principles of the process of globalization and its manifestations are researched in the works: Luttwak E., Huntington S. (2002), Berger L. (2003), Sadlak J. (2002). The vast majority of the authors explored fundamentally the essence and characteristics of globalization, its manifestations. The authors identified the main historical stages of globalization, its manifestations in various spheres, including the emergence and development of transnational business. An evaluation of the results of the authors' research shows that globalization processes are multifaceted, but their impact remains significant and involves the development of appropriate system approaches to leveling down negative processes and ensuring the sustainability of all systems in order to guarantee the security of the world community, both in terms of political equilibrium and socio-economic and environmental criteria of influence on the development of the world economy, the economy of individual states and regions of the world, as well as the preservation of the peculiarities of the mentality of the population. The study of the historical development of the essence of the process of globalization suggests that this is a gradual process of socio-economic, political and cultural integration. The main characteristics of the process of globalization are the global division of labor, the migration of all kinds of resources, the unification of legislation in the field of international cooperation and trade, the spread of new technologies and knowledge. Historical processes of globalization became active in the 20th century, which was due not only to the need for international trade but also to the strengthening of socio-economic, political conflicts, the actualization of the issue of preservation of the natural environment and the growth of environmental risks. The main globalization impact on individual states and regions of the world is manifested through interstate and interethnic relations in all spheres of activity, including the formation of a global market. At the same time, creating a single global market can have a number of risks that can lead to negative consequences and increased social tensions in individual states and regions of the world. That is why the study of the process of globalization, its manifestation through the transnationalization of the world economy remains relevant and requires the formation of new knowledge in order to minimize possible threats and challenges in guaranteeing the security of the world, the co-ordination of national interests of individual countries of the world with globalization manifestations.

3. RESEARCH RESULTS AND DISCUSSION.

The process of forming a single world economic space is multifaceted and controversial. There is globalization and unification of activity, which, in turn, has a tendency to curtail the diversity of business forms. In turn, there are local trends that contribute to the diversity of cultures, norms of behavior, as well as the growth of differences in the way of life. Thus, international business is a multilevel, flexible and open system that is constantly evolving under the influence of various factors - from the simplest forms (foreign trade business) to complex entities (global business). It is revealed that the modern globalization of the world economy is expressed in such processes: deepening, internationalization of production, and not exchange, as it was before. The internationalization of production is manifested in the fact that manufacturers of many countries of the world participate in the creation of the final product in various forms and at different stages. Intermediate goods and semi-finished products take an increasing share in world trade, and between the corporate transfers, the institutional form of internationalization of production, are TNCs (Sovremennaja...2010). Principles of TNC activity are based on the implementation of foreign direct investment in order to create production capacities abroad; the

use of different forms of international division of labor, which allows placing various parts of the production process in different countries of the world; development, transfer and use of innovative technology; Intra-corporate trade, which is carried out between separate units of TNCs using transfer prices that are significantly different from market prices, is significantly higher or lower than the prices for the same goods on the world market. It should be noted that TNCs use a global approach to management, which is based on the optimization of the corporation as a whole, rather than in its individual units, which allows maximization of profits in the long run. Most TNCs are multidisciplinary, which allows them to cover a large volume of different segments of the world market. TNCs can be concentrated in 5 to 50 different industries. So, in the group of 100 leading UK businesses, 96 are multi-sectoral, 78 in Germany, 84 in France, 90 in Italy. Consequently, in recent years, TNCs have taken leadership positions in the global economy, have greatly strengthened the interconnection and interdependence of national economies; in the world trade, the number of TNCs is steadily increasing. TNCs became the main subject of the movement of international investment, technology and operation of international production, which prompted the formation of a global market. The rapid development of transnational corporations in the globalized environment is directly linked to their investment activity. It was foreign investment that formed the basis for the formation of a global system of branches of TNCs and international production, and the investment process is one of the main features of a transnational corporation. The process of transnationalization has led to an increase in the level of interdependence between states and regions of the world and characterizes the strengthening of global integration as a result of global operations of TNCs. It is determined that the process of transnationalization is one of the stages of internationalization of society characterized by the growing role of external factors in the development of states and regions of the world, the creation and expansion of transnational capital. The feature of TNCs is the investment of funds, mainly in the high-tech industry, which provides a corresponding result through the investment income of companies. Most scientists consider transnationalization as a process of expanding the international activities of industrial firms, banks, service companies, and their exit from the national boundaries of individual countries, leading to the expansion of national companies into transnational ones. It is characterized by interweaving of capital by absorption of firms of other countries, creation of joint ventures, attraction of financial resources of foreign banks, establishment of connections between companies and banks at the global level (Table 1).

Table following on the next page

Table 1: The essence, features and manifestations of the process of transnationalization of the economy in a globalized environment

TNC Groups	Criteria and characteristics of TNCs	TNC structure	Manifestations of the process of transnationalization
Horizontally integrated TNCs - manage units located in different countries, producing the same or similar products.	- presence of parent company and units abroad in no less than 2 countries of the world. (divisions can be established by a company on the basis of foreign direct investment through the creation of production capacities or through mergers and acquisitions of other enterprises); - control of assets of foreign units - provides that the shareholding in a subsidiary owned by a parent company in another country is 10% or more.	- a subsidiary is a joint-stock company in the host country, more than half of whose shares are owned by another enterprise; - an associate company is a joint-stock company in the host country, in which 10 to 50% of the shares belongs to a foreign investor; - a branch is an unincorporated enterprise that is wholly or partly owned by the investor, while it may acquire the following forms: permanent representation of a foreign investor in a particular country; non-equity joint venture formed by a foreign investor and third parties;	- increase in the number and activity of TNCs and transnational banks; - a new stage in the internationalization process of the world economy; - change in the nature of involving countries and enterprises in the international division of labor; - intensification of the process of internationalization of economic life, the result of which is the development of international production within the framework of TNCs; - high level of internationalization of production and capital; - the expansion of the scope of TNCs; - new forms of organization of life that contribute to its internationalization.
Vertically integrated TNCs - manage units in a particular country that produce goods shipped to their units in other countries.			
Separate TNCs - manage divisions located in different countries, which are not vertically or horizontally united.			

Source: Summarized by the authors on the basis of the analyzed literary sources

The development of TNCs is a consequence of global integration processes, and the globalization environment itself has led to the spread of TNCs in all regions of the world. The process of transnationalization of the world economy has advantages and disadvantages, while most TNCs have no intention to restrict their own production capacities, while increasing the volume of resources used and exercising significant influence on the ecosystems of the world. The main negative processes take place in view of guaranteeing the economic security of the world's countries, which take investment capital from TNCs, as there is a danger of lowering the rates of development of their own industries and industries.

In the global environment, the 100 largest TNCs that control more than 70.0 percent of all foreign direct investment play a leading role. The largest number is the number of parent companies of TNCs in the US, Japan, Germany, France, Great Britain, PRC. The development of TNCs is a consequence of global integration processes, and the globalization environment itself has led to the spread of TNCs in all regions of the world. The process of transnationalization of the world economy has advantages and disadvantages, while most TNCs have no intention to restrict their own production capacities. The main negative processes take place in view of guaranteeing the economic security of the world's countries, which take investment capital from TNCs, as there is a danger of lowering the rates of development of their own industries and industries. In the global environment, the 100 largest TNCs that control more than 70.0 percent of all foreign direct investment play a leading role. The largest number is the number of parent companies of TNCs in the US, Japan, Germany, France, Great Britain. Trends in the global world economic space determine the processes of production of goods and services, the use of labor sources, the direction of investment in physical and human capital, technology and their distribution from one country to another, which is a requirement of the time. All these large-scale changes affect the competitiveness and efficiency of production, labor productivity and employment. National economies are now more integrated into the world system than any other time in the past (Aheyeva, 2017). Most TNCs have their own interests due to the need to increase the profitability of the parent company, affiliates and representative offices in different countries of the world. Capacity building, increasing the presence of TNCs in various sectors of the world economy and sales markets are accompanied by the scale of investment, which is a requirement of the time for most countries in the world. The investment process involves the technological upgrading of productions, increasing the competitiveness of products, but limits the possibilities of the national economy of the country due to the restriction of sales markets. It is determined that the global market has an impact on the international balance of supply and demand in all segments of the market, changes the relationships between participants in international trade, combines opportunities and creates restrictions that are regulated by the World Trade Organization. It is the global market that influences the gross output of goods in terms of existing needs. Formation and development of the global market, changes in approaches in international trade are under the direct influence of TNCs, which is growing and requires the introduction of appropriate mechanisms for adaptation. Most scientists believe that the process of transnationalization is an objective requirement of time and it is associated with the deepening of the internationalization of world society, characterized by the need to expand the geographical framework of international trade and the need for innovative solutions in all sectors of the economy (Geoekonomaka, 2010). This causes the need to adapt the economies of the world to the process of transnationalization and increase the impact of TNCs on the further development of the world economy. The process of transnationalization is associated with the strengthening of the level of the international monopoly of TNCs, as well as the increased need for resources, including the natural resources of the states that accept investment resources and act as the recipient. The role of TNCs plays an important role in the international financial system, which is associated with most international financial institutions that may act as potential investors for the recipient state. Consequently, TNCs have a significant number of benefits in the global economy, given the unlimited financial capabilities that can lead to the further growth of the level of international monopoly of different groups of global companies and corporations. In order to ensure the national security of the world, there is an urgent need to introduce appropriate mechanisms for interaction, adaptation to global change and the growing impact of TNCs. At the same time, the policy of the countries of the world in a globalized environment should have a long-term character and provide for the implementation of a set of measures to protect the interests of the national economy, including the increasing influence of the process of transnationalization.

The policy of the states of the world in a globalized environment should be oriented towards the mutual co-ordination of their own interests with external processes and phenomena of a globalizing nature. Priorities of the national interests of the state should be not only social but also economic categories based on the creation of a competitive economy, ensuring the growth of living standards and welfare of the population; preservation and strengthening of scientific and technological potential; the formation of prerequisites for the introduction of an innovative model of economic sectors development; providing environmentally and technologically safe living conditions, preserving the environment and rational use of natural resources. Ensuring the national interests of the state in the globalized environment provides the creation of preconditions for guaranteeing material, intellectual and spiritual values due to the priority needs of society and the state, the realization of which guarantees state sovereignty and development of the national economy. Implementation of approaches to protecting the national interests of the state in a globalized environment is driving the development of the economic sectors and public safety. Protection of the interests of the national economy of the state should be based on the strengthening of the influence of state instruments of the influence and motivations on domestic investment of the economic sectors due to the need for the introduction of innovative technologies, creation of new knowledge, strengthening of competitive positions in the global market. Priority approaches for the protection of national interests in a globalized environment were formulated by the authors in Table 2.

Table 2: Priority approaches to protect the national interests of the state in the globalized environment

Approaches	Sources of financing (investing)	Influence of TNCs
Improvement of the regulatory framework in the field of investment	internal sources	insignificant
Control over the implementation of statutory norms by all participants in the investment process	internal sources	insignificant
Monitoring the implementation of investment contract terms	internal sources	insignificant
Implementation of measures to increase the level of investment attractiveness of industries and regions of the state	internal sources, partly external	significant
Assessment of the impact of TNCs on the environment	internal sources	significant
Assessment of the impact of TNCs on society	internal sources	significant
Assessment of the impact of TNCs on the national economy	internal sources	significant
Development of branches of the national economy on an innovative basis	internal sources, partly external	significant
Priority of the distribution of state subsidies due to the formation of the state's GDP	internal sources	insignificant
Preferential taxation for domestic investors	internal sources	insignificant
Activation of the process of creation of new knowledge and technologies	internal sources, partly external	significant

Source: Created by authors

Guaranteeing the national interests of the state and ensuring the security environment in the society should be ensured through a well-considered state policy in accordance with accepted

concepts, strategies and programs in all spheres of activity (political, economic, social, environmental, scientific, technical, informational, cultural) due to the changes in the globalization environment, the growing influence of the transnationalization process, and the international obligations of the state. Protecting the national interests of the state will allow us to adapt to the changes in the global environment, the growing influence of the global market, to determine the priority directions of increasing the competitive positions of the branches of the national economy, to neutralize the opportunities for the growth of social tension in society. The choice of approaches to ensure the national interests of the state is conditioned by the need for decisions that take into account the nature and extent of the potential threats to the globalization environment and must also take into account internal capabilities in implementing measures, including adaptive.

4. CONCLUSION

1. The impact of globalization and transnationalization on the world economy is growing and it changes the approaches to business in all spheres. Adaptation to the transnationalization process requires active involvement of funds in real sectors of the economy in order to increase their competitiveness. In an effort to capture the markets of TNCs, they have a significant impact on the national producer, with much higher competitive advantages and financial opportunities, including investment opportunities. The opportunities of the global market and TNCs create the corresponding threats in guaranteeing the national interests of the countries of the world, the development of national economies.
2. An assessment of globalization processes is a prerequisite for the adoption of global solutions in the economic, social, political, and environmental spheres. Adapting to globalization factors of influence is a significant or even basic prerequisite for guaranteeing the national security of the countries of the world due to the need to ensure socio-economic development, preservation of the national identity of society, leveling out possible manifestations of social tension.
3. Implementation of approaches to protecting the national interests of the state in a globalized environment involves the introduction of a set of actions that should be aimed at developing the national economy and guaranteeing public safety. The protection of the interests of the national economy of the state should take into account the possibility of introducing approaches that will allow them to settle investment processes, identify the interests of all participants, minimize potential threats from the process of transnationalization and strengthen the competitive position of the state in the global environment.
4. The world's politics in a globalized environment should be oriented towards adapting to the growing influence of TNCs, and also taking into account the need to develop, correct and implement appropriate government instruments of the influence in order to ensure the coherence of their own interests with the external growing influence of the process of transnationalization of the world economy. At the same time, ensuring the national interests of the state must be based on the peculiarities of the mentality and the priority needs of the society, the realization of which minimizes the internal and external threats of a global nature.

LITERATURE:

1. Ahyyeva A.A. Hlobalizaciya yak suchasna tendenciya rozvytku svitovoho hospodarstva: sut", protyrichchya, perspektyvy // A.A. Ahyyeva, S.V. Lyashenko // *Ekonomichnyj visnyk Donbasu*. – 2017. – S. 83 – 95
2. Ckejz R. Hlobal"nyj peredel : kak perestroyt" sebya y svoyu kompanyyu : [per. z anhl.] / R. Skejz. — Moskow : Vershyna, 2007. — 210 s.

3. Geojekonomika. Osvoenie mirovogo jekonomicheskogo prostranstva / Je.G. Kochetov. — Moskow : Norma, 2010. — 528 s.
4. Held D. Hlobalizaciya (antyhlobalizaciya) : [per. z anhl.] / D. Held, E. Mak-Hryu. — Kiev. : K.I.S., 2004. — 178 s.
5. Herst P. Sumnivy v hlobalizaciji : [per. z anhl.] / P. Herst, H. Tompson. — Kiev. : K.I.S., 2002. — 306 s.
6. Hiddens E. Nestrymnyj svit : yak hlobalizaciya peretvoryuye tvoji zhyttya [per. z anhl.] / E. Hiddens. — Kiev : Al"ter Pres, 2004. — 100 s
7. Hlobalistyka : istoriya, teoriya : monohrafiya [Tekst] u 2-x tomach / V.I. Vlasov, NNC "IAE", DNSHB NAAN.— Vinnycya : TOV "Nilan - LTD", 2012. — 570 s.
8. Indeks hlobalizaciji krayin svitu po versiyi KOF / Shvejcars"kyj ekonomichnyj instytut (KOF Swiss Economic Institute). / [Elektronnyj resurs]. Rezhym dostupu: URL. <http://globalization.kof.ethz.ch>
9. Piterze Ya. Hlobalizaciya i hibrydyzaciya / Ya. Piterze // *Hlobal"ni modernosti* : [per. z anhl.] / za red. M. Fezerstouna, S. Lema, R. Robertsona. — Kiev : Nika-Centr, 2008. — S. 73—105.
10. Robertson R. Hlokalizaciya : chasoprostir i homohennist" — heterohennist" / R. Robertson // *Hlobal"ni modernosti* : [per. z anhl.] / za red. M. Fezerstouna, S. Lema, R. Robertsona. — Kiev : Nika-Centr, 2008. — P. 48—72.
11. Sovremennaja globalizacija : sostojanij i perspektivy / L.A. Zelenov, A.A. Vladimirov, E.I. Stepanov. — Moskow., 2010.—314 s.
12. Huntington S. (2002). *Global Culture*. London,
13. Berger L. (2003). *Globalization : myths and reality*. Prentice Hall International, Ltd,
14. Sadlak J. (2002). *Globalization and Concurrent Challenges for Higher Education*. London,
15. Dicken P. (1998). *Global Shift : Transforming the World Economy*. N.Y. Guilford Press.
16. Ietto-Gillies Gr. (2002). *Transnational Corporations: Fragmentation Amidst Integration*. London. Routledge. 78 p.
17. Nester W. (1995). *International Relations: Geopolitics to Geoeconomic Conflict and Cooperation*. N.Y. Harper Collins College Publishers.

FEATURES OF PLANNING IT - PROJECT OF MODERNIZATION ACCESS SYSTEM OF SEA PORT

Viktoriiia Denysenko

*Odessa State Academy of Civil Engineering and Architecture, Ukraine
vitka2kd@ukr.net*

Iryna Kornieieva

*Telecommunication technologies LLC, Ukraine
slonik_deni@ukr.net*

Dina Lazarieva

*Odessa State Academy of Civil Engineering and Architecture, Ukraine
dvl7@ukr.net*

ABSTRACT

In article deals with the functioning of the commercial sea port, as one of the important parts of the transport system of Ukraine, which contributes to its hi-grade economic development. As subjects of international relations, sea trade ports occupy a leading place in ensuring the safety of navigation in the territorial sea and inland waters of Ukraine. To meet the current market conditions for the functioning of the transport system, ports need to constantly develop and improve their activities, reducing the cost of work, which is impossible without the implementation and modernization of information systems. For a complete understanding of the processes taking place in the port, it should be considered as a set of production nodes and software complexes that allow automating the work of operators. The detailed analysis of the access system as one of the most important components of the transport infrastructure of the port was carried out in the work. As a model for automation of the access system was chosen a single-channel queuing system. There are calculated the time limits, which the operator can spend on the issuance of one pass. This calculation was based on data of loading of the port's checkpoints for 2016-2017y and the planned growth of the traffic flow. Was estimated the time necessary for each operation to maintain a single vehicle. In article were studied the features of the construction of a data exchange model between different ISs, ensuring stable operation of the port. Substantiated the necessity of modernization of the existing hardware and software for implementing the port development plans adopted for 2018-2022.

Keywords: *access system, data exchange, mass queuing system, sea port*

1. INTRODUCTION

Large trading ports are an important component in the overall structure of the country's economics, being a link between the interior areas of the country and even with neighboring countries that are landlocked. With the help of the port infrastructure, there is a continuous transit of export and import cargoes to the most remote points from the sea borders. The huge economic potential of the ports attracts investors who place industrial enterprises in close proximity to the port, ensuring the growth of employment and welfare of the local population. Competitiveness of the Ukrainian transport complex in the international arena directly depends on the efficiency of the functioning of ports, the conformity of the management system of their infrastructure to international conditions and of the level of their technical equipment. Both external and internal competition between seaports requires appropriate revision of the theoretical and applied rules in the field of logistics management of ports. To meet the current market conditions for the functioning of the transport system, ports need to constantly develop and improve their activities, reducing the cost of work, which is impossible without the

implementation and modernization of information systems. For a complete understanding of the processes taking place in the port, it should be considered as a set of production nodes and software complexes that allow automating the work of operators. Then we can proceed to an analysis of the efficiency of the port's checkpoint from the point of view of the theory of queuing systems. For their study, the methods of statistical modeling are successfully applied, and analytical methods are practically unsuitable.

2. ANALYSIS OF RECENT RESEARCH

The planning and identification of key indicators for software development has been studied by many scientists, for example Teslenko P. [5,16,17], Bokovoi Yu. [6], Ramsin R. [2], Makarov D. [12] The development of theoretical, methodological and practical problems in project management and in particular IT-projects has made a significant contribution by domestic and foreign scientists, such as Goldratt E. [1], Bushuev S. [9], Orlov A. [13], Subbotin A. [15], Serrador P. [3], Borisov S. [7], Budytsky A. [8]. Contribution to the structuring of port performance data was made by Ryzhenkova N. [14], Aung H. [4]. At the same time, the issue of building an IT system for the automation of large enterprises has not been studied at the moment.

3. SUMMARY OF THE MAIN MATERIAL

3.1. Formulation of the problem

To ensure the competitiveness of the port and reduce the cost of infrastructure maintenance, the key performance indicators of the port are laid in the development plan. The average waiting time of the vehicle in the system should not exceed 3.5 minutes, which will be necessary to increase the throughput of the transmission Over the next 5 years, management of the port expecting to increase cargoes traffic flows by 20%.

3.2. Purpose of the research

It is necessary to identify the features of building cooperation between the port's access system and other information systems in order to achieve key indicators.

3.3. Results of research

The port's access system consists of a pass office, four checkpoints and zones for control in warehouses, in the border and customs zones. The central checkpoint passes pedestrians, port employees and transport who do not carry out cargo transportation. A squad of border guards and customs officials does not obey the leadership of the port, so it is not possible to influence their labor productivity. Observations revealed that the greatest time for servicing a vehicle is spent when issuing an entry permit. In our previous works [10, 11] it is justified that in order to ensure that the waiting time of the vehicle does not exceed 3.5 minutes, taking into account the further predicted growth of cargo traffic, it is necessary that the average service time of the vehicle at the checkpoint does not exceed 90 seconds. As a result of monitoring the actions of the personnel at the checkpoint, it was found that the maintenance of the vehicle includes a one-time pass and a scan of the pass to raise the barrier. Data on the time costs are given in table 1.

Table following on the next page

Table 1: The current average time spent on servicing the vehicle

Act	Time, s	Type
Issuance of a pass:	165	Soft+Hard+Hand
- filling of data that confirm the identity of the driver	45	Soft
- filling the data of vehicles and trailers	20	Soft
- filling of data on incoming and outgoing orders	80	Soft
- printing of a pass	10	Hard
- rubber stamp and signature of the person in charge	10	Hand
Return of the driver to the vehicle	20	Hand
Raising of the barrier	15	Hand+Hard
Summary	200	

In cause that is impossible to influence the speed of actions performed by a person, and to exclude the costs of these actions, it is necessary to upgrade the hardware and software. As a result of calculations, it was decided that the additional costs of replacing the hardware are not economically justified, because they will speed up the entire process for only 5 seconds.

Thus, it is necessary to upgrade the software of the port's access system in order to bring the time costs to the indicators given in table. 2.

Table 2: The satisfied average time spent on servicing the vehicle

Act	Time, s
Issuance of a pass:	55
- filling of data that confirm the identity of the driver	10
- filling the data of vehicles and trailers	5
- filling of data on incoming and outgoing orders	20
- printing of a pass	10
- rubber stamp and signature of the person in charge	10
Return of the driver to the vehicle	20
Raising of the barrier	15
Summary	90

From this we see that upgrading the software, we can get a 4-time reduction in costs of time. Conventionally, the upcoming modernization can be divided into two modules:

- automating the filling of data on the driver and the vehicles;
- automating of loading of data on incoming and outgoing orders.

To implement the first module, it is necessary to add the appropriate structures for data storage to the access system and provide a link between them, as shown in Fig. 1.

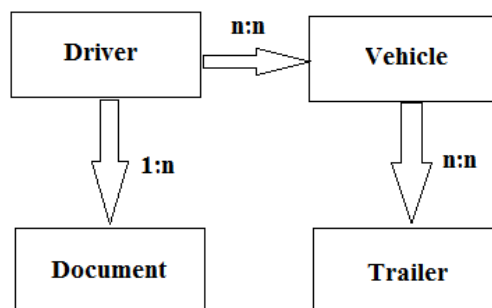
*Figure 1: Types of relationships between objects in the software model*

The most extensive and complex module for automation is loading and retrieving data on incoming and outgoing orders. The difficulty lies in the fact that the documents for entry / exit can be issued by different units of the port and port's administration, as well as by firms operating in the port territory, in particular under the agreements of joint activities. The interaction of information systems serving these units is shown in Fig. 2.

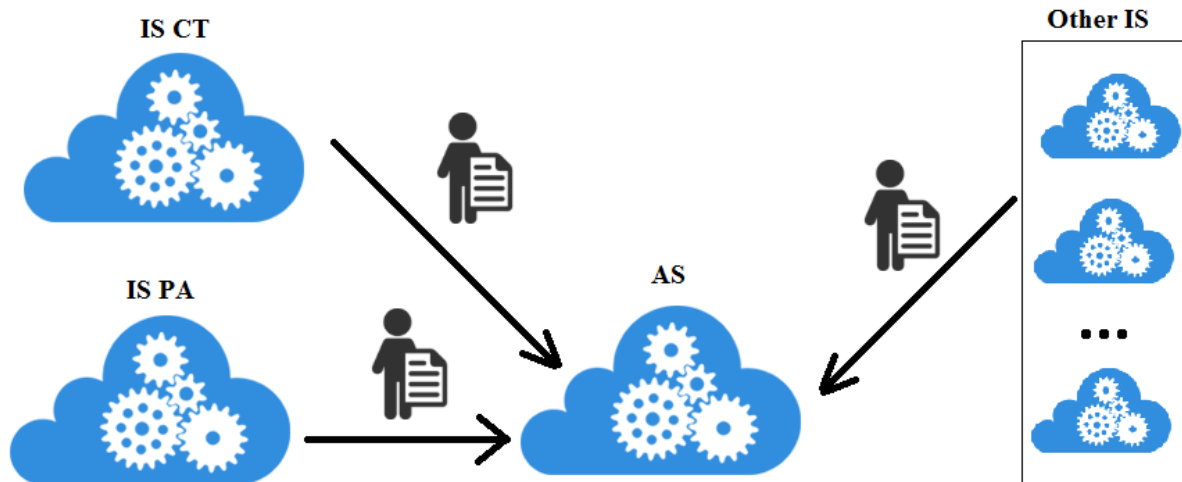

Figure 2: The current interaction of information systems.

There IS CT it's information system, that serving container terminal, IS PA – information system for port's administration, AS – access system of sea port, other IS – different information system's that serving separate organization providing their activities at the port territory. The structure of the cargoes traffic flow and the sources of the permissive documentation are given in Table 3.

Table 3: Percentage of cargoes flows by business unit.

Type of cargo	Source	%
Container	IS CT	73
Oil	Other IS	7
Зерно, шрот	IS PA, Other IS	5
Сера	IS PA	12
Other	IS PA, Other IS	3

Because the largest amount of documentation is accounted for container terminal (73%) and port administration (about 18%), which are serviced by two information systems, it is necessary to adjust their interaction with the IS for passes. Then the interaction scheme will look like it is shown in Fig. 3.

Figure following on the next page

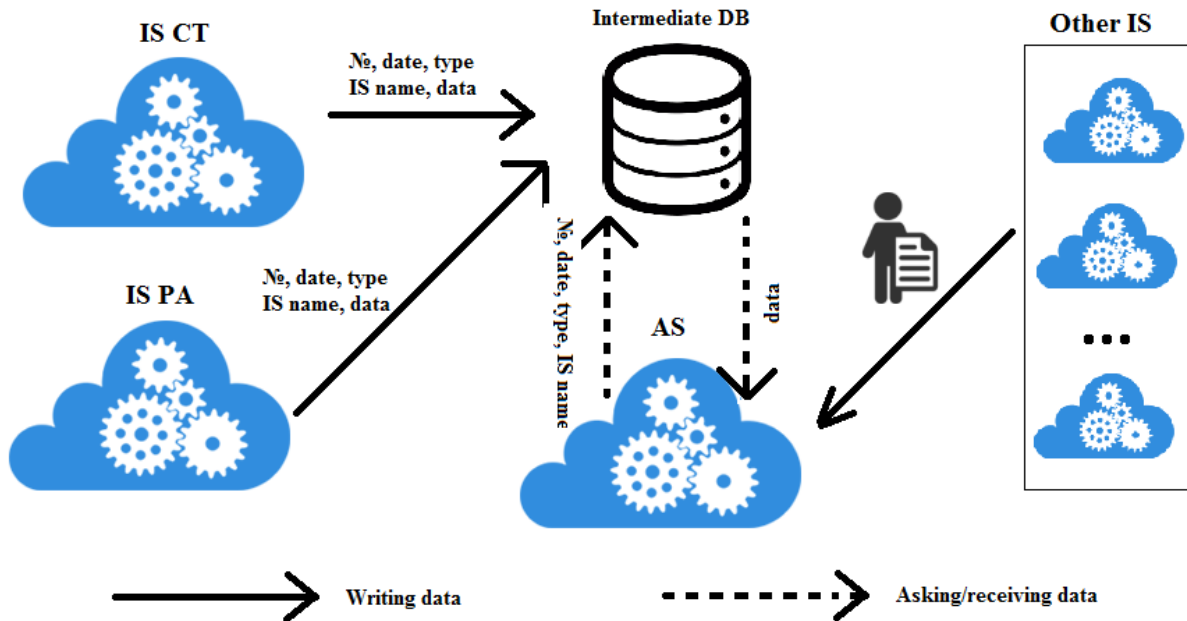

Figure 3: The satisfactory scheme interaction of information systems.

Hence we see that it is necessary to strictly separate the access rights to an intermediate database between information systems. The access system has the right only to request and read data, other information systems have the rights to write objects of a certain structure. At the same time, the data in the intermediate database can be received either at the moment of saving the corresponding document, or accumulated and transmitted in packets. The optimal latency between packet transfers is 10 minutes. As a further development of the access system, can be considered creating of API to access the database of any information system capable of transmitting data in a standardized form.

4. CONSLUSION

In research was:

- considered the structure of the port's port system;
- analyzed the time which spent on servicing the vehicle in the system;
- revealed the distribution by types of resources that ensure the performance of each action;
- made the table of satisfactory expenses on time;
- considered the existing scheme of interaction between information systems;
- proposed upgrade for software to provide automated interaction between IS.

LITERATURE:

1. Goldratt, E. (1997). *Critical Chain*. New York: North River Press.
2. Ramsin, R. (2008). *Process-Centered Review of Object-Oriented Software Development Metodologies*. ACM Computer Surveys, 2008 (ISSN 0360-0300), pp. 35-42.
3. Serrador, P. (2012). *The importance of the planning phase to project success*. Paper presented at PMI® Global Congress 2012—North America, Vancouver, British Columbia, Canada. Newtown Square, PA: Project Management Institute.
4. Аунг, X. (2010). *Моделирование системы массового обслуживания порта Янгон*. Retrieved 30.04.2018 from <https://cyberleninka.ru/article/n/modelirovanie-sistemy-massovogo-obsluzhivaniya-porta-yanhon>.

5. Барская, И, Тесленко, П, Денисенко, В. (2014). *Особенности принятия решения на этапе инициации проектов создания корпоративных информационных систем*. Управління проектами та розвиток виробництва, 2014 (ISSN 2222-8810), pp. 32-39.
6. Боковой, Ю. (2006). *Особенности методологии проектирования информационных систем для малого и среднего бизнеса*. Прикладная информатика, 2006 (ISSN 1993-8314), pp. 3-11.
7. Борисов, С. (2014). *Особенности управления проектами в области информационных систем*. Фундаментальные исследования, 2014 (ISSN 1812-7339), pp. 45-52.
8. Будыльский, А, Квятковская, И. (2014). *Управление командой разработчиков на этапе исполнения ИТ-проекта с использованием метода критической цепи*. Вестник Астраханского государственного технического университета: Управление, вычислительная техника и информатика, 2014 (ISSN 2224-9761), pp. 85-92.
9. Бушуев, С, Бушуева, Н, Бабаев, И. (2010). *Креативные технологии в управлении проектами и программами*. К.: Саммит книга.
10. Денисенко, В, Корнеева, І. (2017). *Визначення вимог до програмного забезпечення для моделі системи масового обслуговування торгового порту*. Науковий вісник Ужгородського національного університету, 2017 (ISSN 2409-6857), pp. 80-84.
11. Денисенко, В, Корнеева, І. (18.12.2017) *Особливості ініціації ІТ-проекту розробки системи масового обслуговування торговельного порту*. Paper presented at international conference Project, Program, Portfolio Management. Odessa: Astra, pp. 42-44.
12. Макаров, Д, Розенберг, М, Шильников, А. (2009) *О факторах риска в процессе разработки программного обеспечения*. Вестник ЮУрГУ, 2009 (ISSN 2076-0493), pp. 85-92.
13. Орлов, А. (2004). *Теория принятия решений*. Москва: Март.
14. Рыженкова, Н. (2017). *Обзор рынка контейнеров в портах Украины в I полугодии 2017*. Retrieved 02.05.2018 from <https://ports.com.ua/articles/obzor-rynka-konteynerov-v-portakh-ukrainy-v-i-polugodii-2017>.
15. Субботин, А. (2013). *Трудозатраты и стоимость портфеля проектов*. Восточно-европейский журнал передовых технологий, 2013 (ISSN 1729-4061), pp. 35-38.
16. Тесленко, П. (2012). *Прийняття рішень в умовах вартісних обмежень проекту*. Управління розвитком складних систем, 2012 (ISSN 2219-5300), pp. 40-43.
17. Тесленко, П., Барская, И., Чумаченко, Е. (12.05.2013). *Особенности проекта разработки и внедрения автоматизированной системы управления контейнерным терминалом*. Paper presented at international conference Управління проектами у розвитку суспільства. К: КНУБА, pp. 248-250.

MARKETING ASPECTS OF URBAN PLANNING AND AGGLOMERATION DEVELOPMENT

Volodymyr Levovich Glazyrin

Odessa State Academy of Civil Engineering and Architecture, Ukraine

Iosyp Volodymyrovych Shkrabyk

Odessa State Academy of Civil Engineering and Architecture, Ukraine

Josef@ukr.net

Mykola Pavlovych Sakhatskyi

Odessa State Academy of Civil Engineering and Architecture, Ukraine

np.sakhatskyi@gmail.com

Pavlo Mykolaiovych Sakhatskyi

Odessa State Academy of Civil Engineering and Architecture, Ukraine

psakhatskyi@readdle.com

ABSTRACT

This article highlights the relevancy of scientific applied processing of marketing aspects of urban planning and agglomerations development. Analysis of researches and publications containing solution of this problem is carried out and generalization of presence of proper theoretical, methodological and methodical basis for application of marketing principles to urban planning and agglomerations development is performed. Part of the researched problem being out of focus of scientists and being unsolved is made more specific. Purpose of the research of marketing aspects of urban planning and agglomeration development is defined. Logics and consequence of conducting scientific applied support of urban planning and agglomerations development on marketing principles is grounded. Odessa agglomeration (Odessa City with its districts and suburbs) is defined as a subject to deeper research. The provisions of Odessa City Development General Plan are estimated for compliance with the basis marketing principles. Compliance of the strategy of social and economic development of Odessa City with general national interests and regional and city specific features is analyzed. Scientific provisions are grounded and practical recommendations concerning implementation of the Odessa City General Development Plan on the materials of Odessa agglomeration. Main priorities of city development on the marketing principles are marked out to solve institutional, social and economic problems of the population, save historical legacy, create natural environment healthy for people, ensure ecological safety of the territory, development of science, education, servicing, recreation and tourism in the city. Importance of scientific consideration of the problem of marketing support of city dwelling construction development is established. Various consumer segments of city dwellers from the point of view of their requirements to quantitative, qualitative, assortment and price properties of dwelling and dwelling-utility services are marked out. Attention is paid to the necessity of satisfaction of the need in dwelling of socially vulnerable groups of population. Marketing commodity policy possible development prospects within the scope of social, economy-class, business-class and elite-class dwelling construction are specified. The importance of keeping balanced commodity, price, distribution and communication policy by developers for effective marketing support of city dwelling construction development is grounded.

Keywords: *Agglomerations development, Marketing aspect, Urban planning*

1. INTRODUCTION

Importance of scientific applied processing of urban planning and agglomerations development marketing aspects is caused by: relevancy of marketing management of economic, social, institutional and ecological areas of agglomerations urban planning as an objecting condition for their long-term balanced development; prospective of application of marketing tools to satisfy the needs of city and suburban settlements dwellers in dwelling-utility comfort and cultural-household facilities in accordance with world standards; turbulence of economic globalization and requiring permanent coordination of interests between commodity manufacturers and consumers, including within agglomerations; increase of competition on investment resources market at which superiority is gained by the agglomerations and territorial societies that actually implement marketing approaches to create favorable environment for business and life of people.

2. ANALYSIS OF RESEARCHES AND PUBLICATIONS CONTAINING SOLUTION OF THIS PROBLEM AND MARKING OUT EARLIER UNSOLVED PARTS

The problem of effective use of marketing attracts attention of a significant number of scientists and practicing persons. Thus, to use logistical and marketing approaches to the development of manufacture-sales infrastructure, I. A. Azhaman refers to the main approaches of scientific-economic support of development of industrial and civil construction [1]. This scientific research reflects both social-economic significance of use of marketing approaches and a wide range of functioning thereof as it includes various sectors of economy and concerns construction in countryside. H. M. Zapsha discloses the theoretical-methodological grounds of development of property relations as an objective condition of market economy existence. It is scientifically grounded that the concept of new economy is reflected by marketing. At the same time, the researched fairly specifies the importance of regulatory policy concerning real estate management that ensures property relations progress [2]. Concerning the urban planning and agglomerations development, it is reasonable to use the conclusion of the scientist concerning marketing as the general idea of market economy and reasonability of formation of state regulatory policy adequate to current requirements. Scientific ground of O. O. Seleznova's processing of theoretical, methodological, analytical, conceptual and project provisions on construction enterprises marketing activity management is based on clear compliance with the research methodology [3]. The monograph underlines that from the point of functional positions the marketing activity of construction enterprises includes a certain list of certain works. The author properly relates market research, discovering necessities, formation of demand, production of construction products, construction goods pricing, distribution, promotion, sales and customer feedback to list of the main of them. Such approach actually enables to take into account the total impact of internal and external factors of microeconomical and macroeconomical environment, to satisfy the consumers' needs in construction goods, to reach social-economical aims by the market actors that is especially important for current agglomerations urban planning. The research by A. Yu. Sobchenko concentrates on methodological approaches concerning the effectiveness of organizational-economical mechanism of countryside dwelling construction renaissance [4]. From the point of view of applied agglomerations urban planning, the author's approach to the necessity of taking into account the interrelations and interdependency of economic, social and natural areas of settlements dwellers life activity is worth special attention. Upon highlighting the preconditions of countryside dwelling construction renaissance by business entities [5], A. Yu. Strenkovska fairly specifies the necessity of systemic approach to solution of the researched problem. The systematic character of agglomerations urban planning also requires systematic approach to determination of scales and structure of production activity of construction enterprises depending on the market demand with simultaneous taking into account of existing market

propositions of competitors. The researches by T. O. Kashchenko state reasonability of making effective architectural decisions in the area of dwelling construction for rational use of energy resources [6]. Such approach should be considered sufficiently prospective due to necessity of decrease of power consumption during urban planning and agglomerations functioning. Solving this problem is conditioned by highly effective construction materials, innovative engineering-technical modules and reliable scientific support of construction. The urgency of increase of energy efficiency of agglomerations buildings is specified in the scientific works by A. M. Prishchenko [7]. Author's argumentation for increase of heat resources saving includes both new construction decisions concerning dwelling buildings external walls and additional warmth-keeping of deepenings from the external side of walls. Complicatedness and uncertainty of run of social-economy and ecological processes in the life of modern city is an objective basis for complex approach to agglomerations urban planning. Namely from such points of view Yu. M. Denysenko [8], H. O. Osychenko, O. A. Pavlenko [9] perform their scientific researches. In his research of problems of brands positioning, Zozulov O.V. indicates the significant influence of state regulatory policy on the effectiveness of marketing activities management [10]. Fairness of this statement is logically explained by the fact that enterprises are parts of opened socio-economic systems, the conditions of functioning of which depend on the environment. The analysis of these and other studies and publications shows the existence of a substantial theoretical base and methodological developments regarding the experience in the marketing activities of economic entities in various sectors of the economy, as well as on urban development and development of agglomerations. However, practice of urban development and development of agglomerations on the marketing basis, as well as scientific grounding of this process from the position of complementarity (ability to be supplemented) remains the unsolved part of the problem under study. In the above studies, there is no systemic link between all components of this comprehensive phenomenon. There is no general generalization of research on marketing aspects of urban development and agglomeration development in the context of specific territorial communities. Issues concerning construction of dwelling real estate and housing and utility services for different groups of consumers are covered in a fragmentary and discrete manner. Based on the relevance and review of publications, the purpose of the study is to substantiate and develop scientific and applied recommendations concerning increase of the socio-economic impact of urban development and development of agglomerations on the basis of marketing. Scientific applied support of urban planning and agglomerations development on the marketing basis involves development and implementation of specific general plans related with respective agglomerations territorial development projects on the basis of detailed planning and implementation of measures on the landscape, architectural, spatial, aesthetic and infrastructure of the territory. It should be borne in mind that in real life urban planning and agglomerations development is carried out entirely specific objects, the study of which serves as the basis for scientific excitability. The final result of urban planning and agglomeration development is the creation of comfortable working, living and recreational conditions, the spectrum of which is able to meet the economic, social and institutional needs of market segments differing by solvency.

3. ODESSA AGGLOMERATIONS DEVELOPMENT PROSPECT ON MARKETING PRINCIPLES

The object of research is Odessa agglomeration that is the city of Odessa with its districts and suburbs. Studies of Odessa General Plan show that its provisions, in general, correspond to the main marketing principles: they have a clear focus on the final socio-economic result, reflecting the priority of long-term interests. They are characterized by complexity of measures to achieve their goals and consumer orientation, which is all the citizens of Odessa and city visitors. In general, adoption and implementation of the General Plan for development of the city, is

consistent with Odessa City Social and Economic Development Strategy up to 2022. At the same time, the means of urban development and architecture, the city's development provides for: compliance with the social-political system of the country; taking into account national interests and regional and urban special features; compliance with market economy requirements; the introduction of modern socio-political, philosophical, religious, institutional, ideological and other ideas into management practice. Thus, in the Territory of Ukraine Planning General Scheme approved in 2001 at the level of the Law, Odessa is assigned the role of the scientific-informational, cultural and tourism center of the country. The idea behind the development of the Master Plan is to develop Odessa as an "Open European City", a multifunctional, oriented to the achievement of the European standard of quality of life, where a high-quality environment of population activity should be created. Development of urban planning on the principles of marketing obliges to see the urban environment, which should include future ensembles of Odessa, where new buildings will be designed using the latest technologies and materials of new generations. They must comply with international environmental and toxicity standards. The historical past and the traditions of creation of the city show that urban planners of the 18th and 19th centuries have already taken care of improving the quality of urban environment in Odessa. The best examples are the gigantic staircases created in conjunction with the two extended, landscaped coastal slopes connected by both sides - parks, in particular the Istanbul and Greek parks. The famous Odessa Opera House is built around two green spaces: the Palais Royal and the square from the side of the Museum of the Navy. Both of these objects are in the number of historical monuments with a unique architecture and a unique organization of urban space. Therefore, the main objective of the new Master Plan is the sustainable development of the city, the solution of social and economic problems, while preserving the historical heritage and increasing the natural resource potential. Another important priority is the creation of a healthy environment for the population and the ecological safety of the territory. According to the provisions of the General Plan, for Odessa the next 20 years shall pass through gradual refocusing to the service economy, which will play an important role in recreation and tourism, will become the main for Odessa. To do this, it is necessary to solve a number of problems caused by low provision of green plantations, sports zones and service enterprises, environmental threats. Extremely sharp problems are those related with transport and road traffic. Intensification as an instrument of urban planning seeks to balance the distribution of density of dwelling development. At present, dwellings take 35% of urban areas, of which more than half is the estate development with an average density of about 45 people per hectare. Therefore, the Master Plan envisages the reconstruction of areas with the oldest manor buildings, where the degree of deterioration is more than 60%. Such districts are Bugaivka, Moldavanka, Blyzhni Mlyny, Sakhalinchik, Tayirove, and Center. Reconstruction allows for freeing up of a total area of up to 190 hectares for development. Also, the Cheryomushki districts of "khrushchevkas" and in the area of the Sehedska Street of total area of nearly 30 hectares are to be reconstructed. Modernization of the industry should be carried out according to the cluster principle. Intra-city transformations will affect existing industrial zones. The general plan is to convert the industrial zones most closely connected to the center, such as "Odessa-Center" in the area of the railway station and "Peresyp" in the north-east of the city. Now in the territory of "Peresyp" there is an environmentally hazardous liquefied gas transfer company. Given the terms of the existing contracts for land lease, the transfer of functions related to gas transshipment beyond the city and the formation of technology parks and logistics in the freed territories as part of environmentally sound knowledge-intensive industries may be completed by the end of the estimated time frame of the master plan. The planned take-over of industrial enterprises located along the Gulf of Odessa will contribute to the improvement of the sea coast and the creation of a fairly large area for recreation and recreation for the city's citizens and visitors.

The general plan provides for formation of a system of new city centers, which allows to significantly free the historical part of the city. The problem of the historic center, which is the most attractive part of the city with the maximum concentration of diverse functions, is a characteristic feature of modern Odessa. The historical core of the city, with its clear regular planning structure, was formed in the first decades of existence. Since then, more than 200 years have passed, but the alternative worthy of it has not been created. New centers are expected to be formed at the expense of reconstructed industrial areas, as well as areas free of construction, and special territories. Each of the centers will have its own specialization. So, at the site of the industrial zones and the prison near the station, it is planned to create a business center "Odessa City". The most radical transformations are waiting for filtration fields located in the northeastern part of the city with access to the Khadzhibeyskyi Liman, and occupy an area of about 1000 hectares. Technopolis Hadzhibeysky will include dwelling (10%), exhibition and fair complex, technopark, landscape park, sports zones. The historic center, with its borders by the Polish descent, Primorska, Preobrazhenska and Deribasivska Streets, is planned to assign the status of a comprehensive protection zone with the prospect of the creation of a historic and cultural reserve "Old Odessa" in the future. A comprehensive approach to the protection of monuments, unlike disperse, allows you to preserve the integrity of the entire historical environment, and not just its individual monuments. Within the city there are two historic areas – "Central" and "French Boulevard", whose priority task is to preserve the traditional environment. Areas provide for building restrictions in height: no more than 18.6 m for the facade, and no more than 21.3 m for in-quarter buildings. Restrictions of development in the historic area are established on the basis of the research work "Historical and Architectural Support Plan, Project of Monuments Protection Zones, Definition of Boundaries and Modes of Use of Historical Areas of Odessa". The planning framework, which defines the structural organization of the city, is formed by the transport highways and landscaped zones. Relatively green areas - the most acute issue is the further development of the coastal slopes. Today, the slopes are built up chaotically, and the public is radically opposed to any construction in these areas. For today, the model of their development is conceptually developed within the framework of the 2012 contest for the project proposal for the use of the littoral area of Odessa from the beach "Lanzheron" to 16 stations of the Great Fontana. In the general plan, the coastal areas from the Park of T. H. Shevchenko to the village Chornomorka are considered an important element of the ecological framework of the city, which appears as a kind of buffer zone between dense urban buildings and the sea. Based on this, coastal slopes are included into the landscape and recreational areas and are allocated to a separate recreational zone. The general plan foresees the further development of transport and road infrastructure. Its important component is the railway connection. In order to unload the existing train station, it is planned to place its new passenger format in the area of the street. Columnar. The key to solving transport problems will be the construction of a system of new highways of the continuous movement bypassing the center, which will liberate it from the freight flow and connect the remote parts of the city. Highway North-South will connect Kotovsky district to the residential areas Cheryomushki and Tairova, and also give a powerful impact for the development of filtration fields. Another highway – West-East - will pass on the M. Hrushevskoho street, through the Leningradske highway and will go on to the Kiev highway. Significant prospects for solving the transport problem of the city are connected with the construction of the subway. According to the new General Plan it is expedient to use a combined scheme of passing metro lines due to the combination of land, underground and overhead sections. Their total length should be 37 km. According to the schedule, the first line of the subway will be along the coast from the district of the same. Kotovsky, crossing the industrial zone "Peresyp", the city center, to the southwestern residential area; the second one - from Fontanska road through the city center to the western industrial area and the new railway station.

In this case, routes along the coast, beloved by Odessa, will be preserved. The plan provides for reconstruction of the existing airport and the development of pleasure sea transport (boats, yachts). In the long run, the length of the city's highway network will increase more than 2 times in relation to the current length of 193 km and will reach 410 km. The primary development of construction should be carried out at the expense of highways of continuous movement, as well as the growth of the length of city and district regulated highways. Further development of the network of bus routes, including the route taxi mode, off-line high-speed transport, improving the network of urban electric transport, in the future increases the overall density of the passenger transport network from 2.17 km / sq. km. to 2.75 km /sq. km. The prospects for city development significantly depend on the use of the city's territory and surrounding areas. In this respect, the joint interaction and combination of resource potentials of the city and suburbs of Ovidiopol, Biliaivka and Liman districts of Odessa region is important. Applied implementation of the Odessa City Development General Plan requires further detailed elaboration of the development of specific areas of the city with the involvement of scientists and practitioners in the field of urban development, architecture, industrial and civil engineering, territorial planning, marketing, economics, management. Establishment of close cooperation between the administrative structures of the city and the Odessa State Academy of Civil Engineering and Architecture directly dealing with relevant scientific researches and training of highly skilled specialists for the construction industry, deserves particular attention. Further development of territorial organization of Odessa agglomeration involves improving the transport and road communication and activating social-economic links of Odessa with such cities as Chornomorsk, Yuzhne, Teplodar. In this context, organizational and economic interaction of all sea and river ports of the region becomes of great importance. The relocation of industrial production outside the city of Odessa requires involvement of the cities of the region – Balta, Izmail, Podilsk, and others. The need for closer cooperation of Odessa with suburban and other village and rural communities of Odessa region is conditioned both by the prospects of structural changes in the city's economy and the importance of solving the problems of the development of region's rural areas.

4. CITY DWELLING CONSTRUCTION DEVELOPMENT MARKETING SUPPORT

The scientific study of the marketing provision of urban housing development involves identifying the needs of specific groups of consumers of residential construction products and identifying measures for a marketing mix that is able to satisfy the investor and enable the developer to carry out extended reproduction in a market economy. Market research shows that housing needs are shaped by different consumer segments of urban dwellers. Their number and ratio in the community for their welfare and social status determine the conduct of the developer of the relevant marketing commodity policy in terms of the scale of construction of housing - social, economy class, business class, elite class. The users of social housing are socially unprotected sections of the population, which include: residents of social dormitories; specialized houses for veterans of war and labor, elderly people and people with disabilities; specialized homes for the poor and homeless; as well as temporary shelters for adult citizens without a definite place of residence; and other persons who enjoy the right to social housing and are in queue for receiving it. Social housing is provided to citizens of Ukraine by local government bodies free of charge and is not subject to sub-lease, reservation, privatization, sale, gift, redemption and pledge [11]. In the construction of social housing, it is worth envisaging its complexity through the addition of the possible construction of specialized buildings, in which the services of medical, domestic, recreational and other nature, which require the above social groups of the population. The effectiveness of marketing a developer in the construction of social housing is to obtain orders for integrated development, free marketing communications in the part of non-commercial advertising, the establishment of strategic

cooperation with local governments regarding the possibility of using their belonging to their main and circulating assets, material, land, organizational and other resources. From the current period, starting with the report for 2015, the state statistical observation on the form No. 4-Housing Fund (annual) "Apartment queue and provision of residential premises" is canceled. Therefore, the official statistics of those who need residential apartments will be submitted for 2014. According to the data of the Main Directorate of Statistics in Odesa Oblast, by the end of 2014, the number of families that were on the apartment account was 34 thousand. During 2014, the number of families who received housing during the year amounted to 78 units. At the same time there is a steady trend of permanent reduction of received housing [12]. Under such conditions, even if we proceed from the assumption that in the future the queue will not be replenished, and the number of families with annual housing received will not decrease, then in this case, in order to fully meet the needs of the inhabitants of the Odesa region in social housing, it is necessary more than 435 years. To avoid this discrepancy and timely fulfill the social housing order from the community of the region, developers should establish close cooperation with local governments on the right to implement residential real estate at the expense of the local budget and in terms of the value of assets, including land plots, the allocation of which is envisaged for future investment contests. Construction of housing economy class is oriented, primarily, to citizens with cash incomes below the average and middle income. Since this category of people belongs to the absolute majority of the population of the country and the city of Odessa, then, accordingly, it is the economy class housing the highest demand and the largest share of the current total construction of residential real estate. Apartments of economy class, by definition, are sold at relatively low prices. Profit is provided by reducing the cost of construction. Therefore, in the construction of housing economy class, for compliance with state building standards and standards, should prevail in typical panel houses without special architectural exploration. In the construction of housing business class should be oriented, mainly, to citizens with average levels of prosperity. Business class apartments should be sold at the most attractive price-quality ratio. Not being located in prestigious and central areas, business-class homes can have a sufficiently high level of infrastructure maintenance for domestic, transport and recreational purposes. It is expedient to increase the additional amenities of the internal house complex, which is a fenced area, security, playgrounds, parking, green zone, flowerbeds, game complexes for school-age children, sports grounds, etc. The highest quality business-class housing is provided by construction in compliance with the state building standards and the existing international quality management system standards. This approach fully meets the marketing requirements. In this case, it is expedient to use high-quality construction material both domestic and foreign manufacturers, and to apply building technologies that allow to receive environmentally safe and energy-efficient housing. The elite-class housing construction is oriented primarily to wealthy citizens who have achieved significant results in life (in trade, management, politics, sports, etc.) due to their own exceptional abilities. That is, the housing of the elite class is a home for the successful. Its location - the central and prestigious areas with a comfortable highly developed infrastructure, the presence of a beautiful view from the window, the proximity of the recreational zone (park, beach, water bodies, etc.). The residential complex benefits from a small total number of apartments, each of which is equipped with modern household appliances and communication systems. In the interior building complex it is necessary to arrange an interesting landscape design with green areas and flower beds, to place sports grounds, playgrounds, playgrounds for school-age children. Obligatory is the enclosure of the territory with access control, round-the-clock video surveillance, the presence of an underground parking, in which one or more parking spaces are located on the apartment. The elite class apartments feature an elevated space that provides comfortable or free planning, or the possibility of redevelopment. An important requirement for elite class houses is the presence of a high ceiling, which is harmoniously

combined with panoramic glazing. Window constructions from floor to ceiling replace wallpapers and wall paintings in picturesque landscapes outside the window, visually expand the space, conventionally combining the room and the street; allow better illumination of the room with sunlight, thereby improving the person. Caring for the vital interests of users of elite-class housing is manifested in the zoning of guest space, recreation area, fitness, spa zone, swimming pool, cozy green area, the presence of at least two bathrooms.

5. CONCLUSION

The main provisions of Odessa City Development General Plan, in whole, respond to the marketing principles as they are focused on consumers, focused on the final social-economic result, priority of long-term interests and complexity of approaches to reach the set aims. Implementation of Odessa City Development General Plan is usually coordinated with Odessa City Social and Economic Development Strategy up to 2022; takes into account the general national interests and regional and city special features; responds to the requirements of market economy; provides for introduction of modern social-political, social-economy, institutional and scientific-technical and other ideas into business practice. The main priorities of stable development of Odessa City are: solution of social and economic problems of population, preserving the historical legacy, increase of natural resources potential, creation of natural environment healthy for people, enrichment of territory ecological safety, structural movements in economy to the development of science, education, servicing, recreation and tourism. Number and proportion of population within the settlers under welfare and social status determines conduction of proper marketing commodity policy by the developer within the terms of the scales of dwelling construction by categories: social, economy-class, business-class, elite-class. The price policy of the dwelling sale must be differentiated and take into account the solvency of population. Effective marketing support of city dwelling construction development provides for keeping balanced commodity, price, distribution and communicative policy.

LITERATURE:

1. I. A. Azhaman. Scientific-Economic Support of Countryside Industrial and Civil Construction: Monography. / I. A. Azhaman. – Odessa: Odessa State Academy of Civil Engineering and Architecture, 2016 – 392 pages.
2. Property Relations Development in Agrarian Sector of Ukraine: [Monography] / H. M. Zapsha. – Mykolaiv: Dyzain ta polihrafiia 2014 – 337 pages.
3. O. O. Seleznova. Construction Enterprises Marketing Activity Management Development in Ukraine: [Monography] / O. O. Seleznova. – Odessa: Odessa State Academy of Civil Engineering and Architecture, 2017. – 356 pages.
4. Sobchenko Ann Methodological support evaluating the effectiveness of organizational – economic mechanism revival housing in rural areas // *British Journal of Science, Education and Culture*, 2014, No.1. (5) (January-June). Volume IV. P.153–161.
5. A. Yu. Strenkovska. Preconditions for Countryside Dwelling Construction Renaissance by Business Entities // *Economics. Finances. Right : scientific magazine*. 2017. No. 3. Pages 4-7.
6. T. O. Kashchenko. Energy Saving Architecture // *Modern Architecture and Urban Planning Problems: Scientific and Technical Collected Book*. Number 1. – Kyiv: KNUBA, 1997. Pages 122-127.
7. A. M. Prishchenko. Increase of Buildings Energy Efficiency by Use of New External Walls Design Decisions / A. M. Prishchenko // *Scientific-Technical Collected Book “Energy Efficiency in Construction and Architecture”*. – Kyiv: KNUBA, 2013. – Number 5. – Pages 221-225.

8. Yu. M. Denysenko. Classification of City Problems from the Point of View of Architecture Integral Nature // Modern City – Problems and Solutions Thereof. – Odessa: ODABA, 2017. Pages 69-71.
9. H. O. Osychenko, O. A. Pavlenko. Natural and Artificial Environment Integration Techniques in Organic Architecture of XX Century // KhDADM Reporter. – 2009. – No. 4. – Pages 80 - 89.
10. O. V. Zozulov. Brands Positioning: Ukrainian Problems / O. V. Zozulov // Marketing in Ukraine, 2002. – No. 3 – Page 38.
11. Law of Ukraine “On Social Designation Dwelling Fund”
<http://zakon5.rada.gov.ua/laws/show/3334-15>
12. Head Administration of Statistics in Odessa Region <http://www.od.ukrstat.gov.ua/>

THE DEVELOPMENT OF THE TOURIST PRODUCT OF THE CITY AND THE INFORMATION NEEDS OF TOURISM ENTITIES

Marzena Wanagos

*Gdynia Maritime University, Poland
m.wanagos@wpit.am.gdynia.pl*

Tomasz Studzieniecki

*Gdynia Maritime University, Poland
t.studzieniecki@wpit.am.gdynia.pl*

ABSTRACT

The possibilities of information transfer, and in particular the dissemination of the Internet and the recognition of information as valuable and important development factor, have led to the increase of the importance of monitoring in recent years. A specific problem is not only the access to information, but verification of the information. The development of regional tourism products requires a special interdisciplinary approach in the field of development policy, its programming and planning, taking into account economic, spatial and administrative aspects. The aim of this study is to show the importance of access and verification of information in the development of regional products in tourism. An important aspect is to present the problem based on the opinion of entities that shape such products related to the development of tourism. Therefore, this study presents the results of a survey carried out among the creators of the tourist offer on the example of the city of Gdynia. The main objective of the study was an attempt of the respondents to assess access to information, information and the willingness to have market information at particular stages of the tourist product development of the area. It was assumed that the information chaos and the lack of a monitoring system and data presentation shows significant weaknesses in the harmonious development of the tourist function of the city. The results of the study clearly indicate the need to intensify activities for the acquisition and processing data that broadens knowledge about the market. This will significantly increase the quality of tourist products in Gdynia and increase the tourists' satisfaction.

Keywords: *city development, market information, tourism product*

1. INTRODUCTION

Effective development, both on a local and regional scale, depends on the response to factors and phenomena determining the activity of business entities in a given area. An effective development policy should take into account the needs of entrepreneurs. Knowledge about the socio-economic environment of enterprises is essential for the sustainable development of the area. It seems to be a necessity to conduct activities, which include (Czochański, 2013, p. 2013):

- diagnosing the state of socio-economic, environmental and pre-spatial situation,
- monitoring changes in states, phenomena and processes,
- analysis of development trends and detection of their creation mechanisms,
- forecasting of development directions,
- inference, evaluation and reconsideration for subject policies,
- directing, introducing corrections and verifying phenomena and accomplishing tasks,
- forecasting changes and achieving effects (factual, financial, social and other).

All these issues require access to a wide range of information. Information is usually disordered and their scope is very wide. In the era of general access to the Internet, we can gain a whole lot of knowledge that is difficult to transform into useful information (Smalec, 2014a).

The implementation of planned tasks related to the acquisition, processing and sharing of socio-economic information, based on a uniform comparable methodology and systematic, allows much more effective and economically justified activity. In the literature, we can find studies on the relationship between obtaining market information and creating products. They refer mainly to the activities of enterprises. Noteworthy is the study by S. Hart, N. Tzokas and M. Saren (Hart, Tzokas, Saren, 1999, p.30). The authors proposed a conceptual model in which many general elements combine in the aspect of developing new products. These elements include, among others: the use of market information, perceived usability of information, types of created products, organizational solutions related to the process of building products and others. D. Dąbrowski (2009, p.7) wrote about the essence of market information in the construction of products, noting that the method of acquiring market information depends mainly on the development stage of the product. In the empirical context, the work of Ch. Moorman, who noticed that the excess of market information flowing into the company may affect the result of the research (information overload). (Moorman, 1995, p.329). The quality of the process of obtaining this information is also very important for the value of acquired information and the opportunities of using it. The low quality of this process may also lead to wrong organization decisions. In the context of proper acquisition and use of information, one should also take into account the specificity of the competitive environment and the risks of obtaining data. Individual business entities operating in given area, operating under competitive conditions, usually do not cooperate with each other in obtaining and exchanging information. The data may be incorrectly processed. Acquiring data regarding competition may also limit innovation, as it leads to duplication of solutions and limits creativity. (Frishammar, Horte, 2005, p.259, Dąbrowski, 2009, p.7, Kotylak, Małachowski, 2017, p.759). The tourist product of the area has its specificity (Holloway, Robinson, 1997, p.118-119, Altkorn, 2000, p.11). Many features, such as network connectivity - products are created on the basis of many related activities of various entities (Wanagos, Smalec, Małachowski, 2017, p.701) make the task of acquiring market information in the product context usually rest on non-governmental organizations or local government organizations (Sołtysik, 2013, p. 8). System solutions in this area are taken very rarely because they are expensive. However, due to the development of the market and the growing information needs, they are becoming more and more appropriate. Process of creating tourist products is based on the specificity of the area (Smalec, 2014b, p.43). Identifying the potential of a place is the basic step of strategic development decisions. Possibilities for the development of diversified functions, relying on forecasting changes is the basis for creating effective solutions and successes of individual entrepreneurs, and thus the entire city.

2. PROCESS OF THE TOURIST CITY PRODUCT CONSTRUCTION AND INFORMATION ABOUT MARKET

In the literature a tourist offer related to a specific city, region or other geographical unit (eg a national park) is referred to the tourist product of the area. Such a product is closely related to the place where it is made. Literature usually lists such features of the product as complexity, complementarity, diversity, synergy (many entities, different relationships, different standards, etc.) (Kaczmarek, Stasiak, Włodarczyk, 2005, p.110, Panasiuk, 2006, p.18). In addition, many specific features appear in various stages of product development, which becomes extremely important in the context of obtaining and using market information. The following stages can be mentioned in the process of creating the tourist product of the area: phase 1 - preparation of the product concept, phase 2 - transformation of the concept into a product, phase 3 - launching the product and its commercialization, phase 4 - quality and efficiency control, phase 5 - product improvement. It is worth mentioning that, according to Deming's concept, the 4th and 5th phase is usually inscribed in the product development and the activities related to these stages should

be implemented in a continuous mode - be repeated (Deming, 1982, p.2). The main groups of market information at each stage are presented in Table 1, which were proposed in accordance with the results of the study (cf. Chapter 3).

Table 1: Main groups of information at individual stages of the tourism product development of the area (own study)

Development stage	Types of information
Preparation of the product concept	<ul style="list-style-type: none"> - information about the entities involved in the creation of the product (their functions, capabilities) - information about the resources of the area and entities shaping the product - information about complementary products - information about potential buyers (mainly needs and preferences) - information about competitive products, including substitution products - information about social conditions (mainly concerns the acceptance of residents)
Transforming a concepts into a product	<ul style="list-style-type: none"> - information about legal conditions - information about financial conditions - information about social conditions (residents) - information about technical conditions (infrastructure)
Launching the product and its commercialization	<ul style="list-style-type: none"> - information about the costs of entering the market - information about the impact on the environment - information about benefits for local entities - information about channels and communication techniques
Quality and efficiency control of the product	<ul style="list-style-type: none"> - information about benefits for residents (social and economic) - information about the opinions of tourists - information about benefits for the industry - information about the impact on the natural and cultural environment
Product improvement	<ul style="list-style-type: none"> - information about the possibilities of the participating entities - information about the competition - information about the impact on the environment - information about the acceptance of residents

The general division of the market of information proposed in the literature is described as information on buyers, information on competition, general market information (Dąbrowski, 2009, p.12). In the context of a tourist product, the information is described as:

- information about buyers - should be interpreted as information not only on tourists, but also hikers and residents, who make up a small part of customers,
- information about competition - these may be other products and entities in a given area, but also products with similar functions in other areas and those that constitute substitute products,
- other market information - constitute a wide range of data, e.g. about the natural environment, about the social and cultural environment, about organizational aspects, etc.

In the spatial approach (product of the area) in relation to the shaping of a specific function of the area, a very important role should be attributed to information on residents who are the main beneficiaries of benefits (infrastructure development, a wide range of services also available to residents - recreation, gas supply, raising living standards, higher income local government, etc.). On the other hand, residents can also bear the costs of developing a specific tourist function (transforming space - investments, environmental pollution - including noise, etc.) (Ahn, Lee, Shafer, 2002, p.18, Kizielewicz, 2015, p.188). Information about the residents' acceptance is important at every stage of the tourist product development of the area (Markowski, 1999, p. 60, Wolska, Kizielewicz, 2015, p.148).

3. THE ESSENCE OF MARKET INFORMATION IN THE ASSESSMENT OF GDYNIA'S TOURIST ENTITIES - METHODOLOGY AND ANALYSIS OF THE STUDY

The aim of the study was to identify the information needs of tourism entities in the development of tourism in the city of Gdynia. The results illustrate the respondents' opinion regarding the access to information, the state of having information and the desire to have information in the process of developing the tourist product of the area. The survey was carried out from August 2017 to April 2018 in Gdynia. Gdynia is a city on the Gulf of Gdansk, inhabited by about 200 thousand people (Statistic Yearbook of Gdynia City, pp.126-142) with a dominant industrial and commercial function (mainly related to the seaport) (Urbanyi-Popiołek, 2014, p.344). The tourist function of the City is a complementary function. It is not apparent from any City documents that the tourist function should be made a leading function. This City is an example of use the tourist potential to increase the importance of recreational, gastronomic and business services, as well as culture and sport. The members of tourist industry comes together as part of the Tourism Council Established by the City. At these meetings, problems relevant to the development of tourism are discussed. In the period from August 2017 to May 2018, five meetings were held with the tourist industry of the city, in which 52 entities (both commercial and not-for-profit) participated in total. These meetings were used to implement the research objectives analyzed in this study. As a method, a diagnostic survey was carried out using a questionnaire technique. The structure of the surveyed entities can be equalized: 34% of hotel enterprises, 21% of catering enterprises, 6% of travel agencies, the remaining 38% are other entities. 81% are commercial entities and 19 are non-profit entities. In the first stage, respondents were asked to indicate groups of the most important information according to their opinions in the various stages of the tourism product development of the area. Respondents were to assign weight to specific information groups (on a scale of 1 to 10, where 1 was the least important group and 10 the most important). Those groups, where score exceeded the average score of 5 were accepted for further investigation. In the second stage of the survey respondents expressed their opinion indicating 1-10 to individual groups of information (1- lowest grade, 10 highest grade).

The assessment concerned three problems: the assessment of access to information in a given area, the assessment of knowledge in a given area, the assessment of the willingness to have knowledge of a given area.

Table 2: Opinion of respondents on different groups of information at various stages of development of the tourism product of the area in terms of access, possession and willingness to own (own study)

Development stage	Types of information	Access to information	The status of having information	The desire to have information
Preparation of the product concept	information about entities participating in the creation of the product (their functions, possibilities)	8,3	4,5	5,6
	information about the resources of the area and entities shaping the product	7,1	6,5	9,5
	information about complementary products	5,3	4,5	7,4
	information about potential buyers (mainly needs and preferences)	4,4	3,5	9,4
	information about competitive products, including substitution products	5,5	3,4	8,3
	information about social conditions (mainly concerns the acceptance of residents)	7,5	4,4	9,7
Transforming concepts into a product	information about legal conditions	8,4	7,6	9,5
	information about financial conditions	5,7	8,3	9,8
	information about social conditions (residents)	4,8	5,6	8,5
	information about technical conditions (infrastructure)	8,2	8,5	8,7
Launching the product and its commercialization	information about the costs of entering the market	7,3	8,5	9,8
	information about channels and communication techniques	5,4	6,5	9,1
	information about the benefits for the entities shaping the product	6,5	6,4	9,3
	information about the impact on the environment	6,4	5,2	8,5
Quality and efficiency control of the product	information about the benefits for residents (social and economic)	8,5	4,3	8,8
	information about the opinions of tourists	8,3	3,8	9,4
	information about the benefits for the industry	5,2	4,7	9,8
	information about the impact on the natural and cultural environment	6,3	3,4	7,4
Product improvement	information about the possibilities of participating entities	7,6	8,3	9,7
	information about the competition	4,3	5,4	8,8
	information about the impact on the environment	6,5	4,3	7,6
	information about the residents' acceptance	8,4	4,3	7,7

Analyzing the results of the study, it can be noticed that the highest values of respondents' assessment appear with the 'willingness to have information', slightly lower ratings were given for 'available to information', and the lowest for 'information possession'. Unfortunately, it results from the fact that the state of knowledge of the entities is not considered very high. Despite the fact that they recognize that access is quite large, the state of having information is relatively low. The most desirable information (on average over 9 points) includes: information on the resources of the area and entities shaping the product, information on potential buyers, information on social conditions (residents). In the product verification stage, the most anticipated are: information about costs of entering the market and information on the opinions of tourists and benefits for the industry. What is quite surprising, is the fact that the surveyed entities have very little assessment of their knowledge. Despite the wide access to various sources of information, entities do not fully use it. They assess knowledge about buyers very low (3.5). At the same time, it should be emphasized that this is information that is highly regarded as desirable (9,4). Respondents also lowly assess the state of their knowledge in the field of information on competing products. Undoubtedly, knowledge about the market, its elements and condition is a very valuable resource for entities shaping the tourist product of the area. The research shows that all entities declare the will to expand it.

4. CONCLUSION

The development of the tourist product of the area requires the cooperation of many entities and use of a lot of information. The specificity of such product - its complexity and complementarity, the involvement of various entities (commercial and non-profit), creates unique conditions for the process of obtaining market information. Organizing the scope of obtaining information usually depends on the specificity of the place and the product itself. Entities shaping the tourism product of the area use market information to achieve the desired effects. From the research conducted on the example of Gdynia, it can be seen that the knowledge of entities building the city's tourist sub-region and obtaining information is insufficient. The evaluation regarding the state of knowledge is low in research. However, the assessment of the desire to possess the information is on high level. It follows that entities express a desire to have a much larger range of information than they have. The most valuable information for the surveyed entities is information about the client and financial aspects. The knowledge about the market is needed for entities shaping the product at every stage of product development. The scope of information obtained and used depends primarily on the activity of these entities, indication of the desired knowledge and their organization.

LITERATURE:

1. Ahn, B. Y., Lee, B. K., Shafer, S. C. (2002). Operationalizing sustainability in regional tourism planning: an application of the limits of acceptable change framework. *Tourism Management*. vol. 23. no. 1. pp. 1-15.
2. Altkorn J. (2000). *Podstawy marketingu*. Kraków: Wydawnictwo Instytucji Marketingu.
3. Czochoński, J.T. (2013). *Monitoring rozwoju regionalnego. Aspekty metodologiczne i implementacyjne*. Warszawa: Polska Akademia Nauk.
4. Dąbrowski, D. (2009). *Innowacje rynkowe w rozwoju nowych produktów*. Gdańsk: Wyd. Politechniki Gdańskiej.
5. Deming, W.E. (1982). *Quality. Productivity and Competitive Position*. Cambridge, Massachusetts: MIT Press.
6. Frishammar J., Horte S.A. (2005). Managing external information in manufacturing firms: the impact on innovation performance. *Journal of Product Innovation Management*. Vol. 22. No. 3. pp. 251-266.

7. Hart, S., Tzokas, N., Saren M. (1999). The effectiveness of market information in enhancing new product success rates. *European Journal of Innovation Management*. Vol. 6. No. 1. pp. 20-35.
8. Holloway, J.Ch., Robinson, Ch. (1997). *Marketing w turystyce*. Warszawa: PWE.
9. Kaczmarczyk J., Stasiak A., Włodarczyk B. (2004). *Produkt turystyczny. Pomysł. Organizacja. Zarządzanie*. Warszawa: PWE.
10. Kizielewicz, J. (2015). Ethical Standards for Regional Authorities in the Creation of Strategy for Regional Development [In:] *Proceedings of the 11th European Conference on Management Leadership and Governance – ECMLG 2015 (ECMLG)*, Lizbona. Academic Conferences and Publishing International Limited. UK. pp. 186 – 193.
11. Kotylak, S., Małachowski, K. (2017). The impact of infrastructural development on the sector of creative and cultural industries. [In:] *6th Central European Conference in Regional Science – CERS*. Banska Bystrica: Matej Bel University. pp. 756-767.
12. Markowski, T. (1999). *Zarządzanie rozwojem miast*. Warszawa: Wyd. Naukowe PWN.
13. Moorman, Ch. (1995). Organizational market information processes: Cultural antecedents and new product outcomes. *Journal of Marketing Research*. Vol. XXXII. pp. 318-335.
14. Panasiuk, A. (ed.). (2006). *Ekonomika turystyki*. Warszawa: Wyd. Naukowe PWN.
15. Smalec, A. (2014a). Trade shows and exhibitions as a form of promotion of regional, local and traditional Products. [In:] *Conference: International Scientific Conference on Economic Science for Rural Development*, Location: Latvia Univ Agr, Fac Econ & Social Dev, Jelgava, Latvia.
16. Smalec, A. (2014b). Economic science for rural development: marketing and sustainable consumption. Rural development and entrepreneurship. *Home Economics Book Series: Economic Science for Rural Development*. Issue: 35. pp. 43-51.
17. Sołtysik, M. (2013). *Uwarunkowania i modele międzysektorowej polityki turystycznej w podmiejskich gminach Legnicy i Wrocławia [Determinants and models of inter-sector tourism policy in the suburban municipalities of Legnica and Wrocław]*, Studia i Monografie Akademii Wychowania Fizycznego we Wrocławiu. No 116. Wrocław.
18. *Statistical Yearbook of Gdynia City*, Statistical Office in Gdańsk, Retrieved 15.05.2018 from file:///C:/Users/Asus-R558U/Downloads/RocznikGdyni2016.pdf
19. Urbanyi-Popiołek, I. (2014). Cities Cruise industry in the City of Gdynia, the implications for sustainable logistic services and spatial development. [In:] *1st International Conference Green Cities 2014 - Green Logistics for Greener*. Procedia - Social and Behavioral Sciences 151. pp. 342-350.
20. Wanagos, M., Smalec, A., Malachowski K. (2017). Local Government Activities Relating to Local Entrepreneurship By Tourism Entities in The Pomeranian Voivodeship. [In:] *20th International Colloquium on Regional Sciences Location: Kurdejov, Masaryk Univ, Fac Econ & Adm, Dept Reg Econ & Adm Czech Republic, JUN 14-16*, pp. 700-706.
21. Wolska, G., Kizielewicz, J. (2015). Corporate social responsibility in Poland – theory and practice, [In:] *Innovation, Leadership & Entrepreneurship Challenges of Modern Economy*. DIEM – Dubrovnik International Economic Meeting. University of Dubrovnik. Dubrovnik: University of Dubrovnik. pp. 143-155.

INTEGRATED EDUCATIONAL BRANDING AS SOURCE OF MARKETING COMMUNICATIONS OF HIGHER EDUCATIONAL INSTITUTION

Svitlana Yermakova

*Odessa State Academy of Civil Engineering and Architecture, Ukraine
ermakova.s2011@yandex.ua*

ABSTRACT

The integration of Ukraine into the international economic environment meets the general principles of civilization that dominate at the present stage of the world economy. Globalization as a systemic geoeconomic and geopolitical phenomenon leads to increased risks for Ukraine considering its inadequate competitiveness, and therefore the search of a vector for own path of development, an effective management format for the domestic economy is the guarantee for successful integration into the global economy. Education, considered as an element of the innovation economy, plays a fundamental role in preparing the intellectual resources of the country not only for producers, but also for the social sphere, that is the role of education extends beyond the triad: education, science and production. The economic success of development of a higher educational institution depends directly on its competitiveness in the education market, on the chosen development strategy, the diversification of commercial efforts – all areas of activities specific to the brand of a higher educational institution. Brand in the field of education is the guarantee of quality of an educational service or a scientific product obtained, its reputation, image, associations that arise in the minds of people when they see the attributes of an educational institution. The brand in current environment is also a part of all the processes in activities of the higher educational institution, and such marketing communication tools as advertising, public relations, introduction of educational start-ups, educational fairs or conferences, training seminars, trainings, coaching intensities, direct mailing, supporting materials, etc. play an important role in the educational and informational brand of a higher educational institution. Considering these tools as brand translators is a good way to understand their role. They allow to transfer the educational drivers of a higher educational institution. The process of creation and promotion of brands of higher educational institutions corresponds to the modern market conditions of development of society, which have inherent characteristics such as globalization and chaotic nature. In such conditions, the brand has certain advantages which enable it to remain competitive and to achieve commercial success. However, modern educational modernizations do not always contribute to the rapid response of higher educational institutions to numerous changes. From an organizational point of view, branding is a set of consistent measures aimed at creating a holistic and consumer-friendly image of a higher educational institution, whose algorithmization allows to visualize this process and to simplify the construction of the brand as much as possible. Consequently, all integration processes of higher education are aimed at getting out of a tight framework taken as a "start". Nowadays the integrated educational branding is offered as an ideological adjustment for educational marketing.

Keywords: *brand, branding, brand translators, higher education, integrated educational branding*

1. INTRODUCTION

System modernization of the domestic economy as a dominant mechanism for increasing its profitability is capable of integrating the powerful potential of the country and externalizing it into general national enrichment (Makashev M. O., 2004). Increasing the economic potential of Ukraine to the level of developed countries will provide an additional impetus from

integration with other countries on a parity basis by attracting additional external resources – financial, innovative and intellectual into the economic turnover (Rotov A.S, 2010). The innovative economy needs advanced technologies and equipment, a new educational system that will provide updates of intellectual potential. The determining role in training specialists and establishing scientific and technical, cultural and educational ties which form the educational system belongs to the institutions of higher education. The use and dissemination of new knowledge becomes the basis of national competitiveness and the basic pre-condition for the intensive growth of the country's economic potential. The fundamental scientific research offers new knowledge to people which transforms into technology and products of knowledge-intensive production, stimulates the productivity growth, the reduce of material and energy consumption, the increase of the competitiveness of social production, accelerating the pace of accumulation of social income, changing the motivation of labour, improving the general welfare of citizens in the country. (Abalmazova M. E., 2013). Scientific potential as the component of innovation potential is determined by the aggregate of resources and organizational, managerial forms for productive realization of opportunities not only in the sphere of science, but also in education, production of any system (of an enterprise, territory, industry, country). Thus, the relationship between science, education and production creates the preconditions for the development of scientific potential. In turn, the state acts as a key investor in the Ukrainian educational system, since such costs are of social benefit. Therefore, the economic success of the development of a higher education institution directly depends on the competitiveness of the higher educational institution in the education market (not only domestic but also international), on the chosen strategy of development, diversification of commercial efforts – all areas of activities inherent in the brand of the higher educational institution. A brand in the field of education is a guarantee of the quality of the educational service or scientific product obtained, its reputation, and image.

2. CONCEPTUAL AND METHODOLOGICAL BACKGROUND OF THE BRANDING THEORY OF HIGHER EDUCATIONAL INSTITUTION

The process of creation and promotion of brands of a higher educational institution complies with the modern market conditions of the development of society with inherent characteristics such as globalization and chaotic nature (Makasheva Z.M., 2010). In such conditions, it is the brand that provides certain advantages to a higher educational institution which enable it to remain competitive and to achieve scientific, educational and commercial success (Serkova E.V., 2010). The conceptual and methodological basis of branding theory was laid in the fundamental works of scholars such as D. Aaker, G. Armstrong, B. Vaneken, S. Davis, F. Kotler, S. Kumber and others. The main models and branding tools are presented in the studies of foreign and domestic experts (A. Bayle, S. Van Gelder, A. Dilgach, S. Kumber, V. Pertsiiia, E. Popov, K. Seriohina, O. Serebrennikova, A. Tsvetkov, P. Chernomaz). Although the provision of basic branding tools creates productive preconditions (Zavhorodnia T.V., 2010) to achieve certain positions in the market of educational services and to ensure decent competition, the important theoretical and practical problems of generalization and analysis of the essence and classification of brands of higher educational institutions, the problem of formation of an educational brand of a higher educational institution as a source of marketing communications and as an effective factor for increasing competitiveness of the national higher education are still unattended today.

2.1. Peculiarities of Formation of Integrated Educational Brand of Higher Educational Institution as a Source of Marketing Communications

Nowadays, the most powerful countries of the world in terms of economy have the status of an information society, in which the primary importance belongs to the educational sphere.

Similar problems are faced by the national system of higher education. In order to fully meet the latest requirements, modern higher education institutions should actively use innovative marketing tools in their activities including advertising and public relations. At the same time, the aggregate of methodological marketing tools actively used by educational institutions is characterized by the absence of a holistic concept of branding, innovative activities directed at the formation and development of a brand. This significantly make actual the need for a comprehensive scientific study of the theory and practice of the brand formation of a higher educational institution. Meanwhile, the brand is considered an effective tool that helps to better orient in the diversity of educational services and is one of the most important factors for increasing the competitiveness of a higher educational institution. In other words, owing to the brand of a higher educational institution, consumers, on the one hand, receive a certain range of guarantees regarding the quality of educational services, and on the other hand, the brand ensures loyalty of the audience and raising the level of consumer awareness. In general, brand building begins with the establishment of a higher education institution that will be its embodiment. In case of the need to build a brand for an existing institution of higher education, the step of "establishment" is skipped. In the study, the branding of a higher educational institution is defined as the process of creating, developing and managing the brand, the main way to identify the higher educational institution, the tool for its introduction into the market and establishing a long-term communication with consumers. From an organizational point of view, branding is a set of consistent measures aimed at creating a holistic and consumer-friendly image of a higher educational institution, whose algorithmization enables to visualize this process and as much as possible simplify the building of the brand. While developing the brand, it is important to take into account that the main consumer of educational services are students obtaining higher education – those studying or having a desire to study at the higher educational establishment in order to obtain the appropriate degree and qualification. However, it is worth not neglecting another group of consumers, which includes the parents of future students who take part in the decision making as to the choice of a higher educational institution as well as companies that are interested in obtaining higher education by their employees. This will help to identify the sources of marketing communications with all consumer groups and increase the productivity of this dialogue. All processes of the branding algorithm must be consistent with the philosophy of the object which essentially prompts other people to act in accordance with their goals and is considered as a system of guiding principles that is the basis of action taken by the employees in relation to each other and to the consumer (students, post-graduate students, etc.). In the course of the study, it was determined that algorithmization of branding characterizes the process of branding of a higher educational institution in one plane, but in fact the process of branding develops in a spiral way, otherwise, further development and promotion of the brand would be blocked because its "life journey" is very short. The idea of a spiral form of the development of history appeared on the principles of dialectics. In the light of the "negation of negation" law, the development of history splits into separate, relatively independent stages, where each subsequent stage is associated with the previous negation – a necessary and essential element of development. At the beginning of the last century, academician V. Vernadskyi formulated the role of human intelligence as a productive force of global scale and linked the further development of mankind with science, intelligence and humanism, that is, with "noospherization," so it is no coincidence that the structure of the integrated brand of a higher educational institution in this study symbolizes a solar system which naturally holds the brand of a higher educational institution, the brand of organization, the brands of its services, the brand of territory, the brand of events, the brand of intellectual property products and even the brand of personality in the orbit. Each of the "planets" rotates in its own orbit, so it has a strategy for development and promotion, has specific tasks which in aggregate are consistent with the general strategy of the higher educational institution and are

focused on the general consumer. Take into account the specific features of educational services, the integrated educational brand of a higher educational institution can be defined as the process of forming a set of techniques and methods that can bring the developed brand of a higher education institution to the consumer of educational services and form the image of an educational institution in his mind and thereby providing effective assistance for an entrant in the perception and analysis of the distinctive features and advantages of one or another higher education institution. That is, in this context, the brand of a higher educational institution represents the expectation of consumers of educational services in terms of obtaining a specific benefit as a result of education, taking into account not only obtaining a particular specialty, but also further career development. Thus, the strategy of the "spiritual" leadership is clearly defined as the vector of success of a higher educational institution in general and branding in particular. It is this strategy which makes potential consumers interested in high-quality, emotional values of the brand of a higher educational institution.

2.2. The Role of Integrated Marketing Communications in the Context of Successful Functioning of Higher Educational Institution

Productive application of integrated marketing communications by higher educational institutions and the introduction of new methods of their management require, first of all, the definition and understanding of the essence of such concept as "integrated marketing communications" (Siniaieva I.M., 2012). Depending on the tasks set out by individual scientists and researchers in their works, there are different approaches to the interpretation of the term "integrated marketing communications" (Krasnyuk I.M., 2013). It is believed that the concept of "integrated marketing communications" combines all the tools of marketing communications, from creating an image to the formation of a picture, from advertising to a system of appeals or creating a separate slogan (Becker E.G., 2012). In general, the specificity of integrated marketing communications is made actual in the use of all means of marketing communications, whose task is to transmit the value message to the target audience. Nowadays, the successful management of a higher educational institution requires full orientation towards a specific consumer of goods and services with long-term relationships, and not to segmental consumer markets (Sharkov F.I., 2006). Therefore, a stable competitive position of a higher educational institution in the market is ensured by the integrated marketing communications as the only functional area where all means of marketing communications are coordinated and based on the use of a single logo (Schultz D.E., 2004). This is a new way of understanding branding from the standpoint of consumers. For a modern institution of higher education, taking into account all factors of the educational environment, such an approach is extremely relevant, in particular, the orientation towards a particular consumer of educational services. Focusing on the use of integrated marketing technologies when building the brand of a higher education institution, it was noticed in the study process that their peculiarities should be taken into consideration, namely, paying more attention to consumers of intellectual property products (or educational services), their users and potential clients, rather than the main tasks of the educational institution to increase sales or profit. Thus, the essence of integrated marketing technologies lies in the coordinated communications with the needs of consumers in focus and in order to create the value of intellectual property products which differentiate it from products of competitors in the minds of consumers. However, the productive use of integrated marketing technologies for the successful communication of a higher educational institution with a potential consumer of educational services is preceded by their "modelling", which primarily involves identifying a target audience and developing a well-coordinated program (concept) for promoting an intellectual property product or educational service in order to get the desired reaction of consumers. The concept of integrated marketing communications is the development of a single program for a marketing campaign, personal sales, sales promotion

and public relations (Sharikov F.I., 2006). However, in our opinion, this approach only partially reveals the elements of the integral marketing communications complex of the higher educational establishment, since the means and techniques used by the indicated communications are much wider and go beyond the scope of the use of the presented means only. Modern institutions of higher education currently have the opportunity to use integrated marketing communications which combine advertising, direct marketing, promotion, personal sales, public relations, marketing publications, exhibition marketing, interactive marketing, corporate identity, sponsorship, unplanned communications, and others (Kotler F., 2011). Thus, there is a need for higher educational institutions to conciliate and coordinate all efforts in the field of promotion of educational services, namely the use of integrated marketing communications, their "modelling" which is a system of elements of marketing communications. It enables to integrate individual messages in order to ensure consistent and targeted impact on different groups of communications recipients. In this case, the values, contained in the brand of the higher education institution and transferred to a consumer, form the fundamental part of the integrated educational branding platform of a higher educational institution.

3. MODELLING THE PLATFORM OF INTEGRATED EDUCATIONAL BRAND IN MARKETING COMMUNICATION SYSTEM OF HIGHER EDUCATIONAL INSTITUTION

Proper development and application of the concept of integrated educational brand of a higher educational institution is one of the important strategic tasks for the heads of higher educational institutions. At the same time, any activity regarding the positioning of a higher educational institution in the minds of consumers of educational services should be based on the understanding of the importance of both educational goals and objectives by the administration as well as on the building of a platform for the formation of the brand (Hryshchenko I.M., Krakhmalova N.O., 2012). The platform of an integrated educational brand of higher educational institution is built and structured on the basis of in-depth monitoring carried out at different decision-making levels. The place of the platform in the general scheme of building an integrated educational brand of a higher educational institution and its detailed structure are modelled according to educational goals, needs and tasks of occupational training of future specialists at a higher educational institution. The values contained in the integrated educational brand of the higher education institution for the consumer of educational services form the fundamental part of the platform of the integrated educational brand of a higher educational institution.

3.1. Platform of Integrated Educational Brand of Higher Educational Institution

The functional benefits identified at the stage of the object creation (individual educational programs of the higher educational institution, training courses, providing of educational innovations, special professional staff of the higher educational institution, etc.) are the primary internal identifiers, according to which the consumer of educational services determines conformity of the values of the integrated educational brand of the higher educational institution with his own attitudes. As for the secondary benefits, they arise for consumers in direct contact with a higher educational institution, but they should be realised and recognized before establishing this contact, because this understanding will be the pivot for building the external identification of a higher educational institution. Secondary advantages include the social, mental and spiritual benefits, the understanding of which helps to create a brand code, a DNA of a higher educational institution, which ensures the unique nature of the integrated educational branding of a higher educational institution in the modern world. In turn, social benefits provide consumers with the ability to identify themselves with a particular social group (self-

identification), to express own educational mission. Thereafter, mental benefits support a person's confidence, inspiration, good mood, pleasure, psychological rest, the intense perception of authenticity. This measurement really penetrates into the personality. In this case, the brand affects what most of us would call a soul. Mental benefits influence the personal transformation, so they can change or contribute to the development of a new understanding of oneself, and we firmly believe that some of the best integrated educational brands of higher educational institutions of tomorrow will play the role of a personal coach that will contribute to the mental development of branding consumers. Spiritual benefits are perception of global or local responsibility, a sense of belonging to the solution of global problems of society, the introduction of further cultural development, innovation of higher educational institution. Thus, the platform of the integrated educational brand of a higher educational institution is an instrument for forming a unique set of elements of an integrated educational brand of a higher educational establishment that will enable it to differentiate in difficult market conditions. An important key element of the brand platform is its legend and mission. The legend of the integrated educational brand of a higher educational institution is the history of its origin presented in the form of interesting facts and based on historical components. The legend defines "the age of brand", describes its history and largely determines its further development. The mission of the integrated educational brand of a higher educational institution is the purpose for the brand to exist, which is presented in the most general brief form and often expresses the main reason for its existence, it is a fundamental program statement that defines the most important principles of functioning and development, gives a message to the external environment about its aspiration and promotes the formation of a certain image of an educational institution and the creation of a corporate spirit. The final element of the platform of the integrated educational brand of a higher education institution is the appearance of a higher educational institution, which includes elements enabling to create a visual identity of the brand and to make it distinct from competitive brands. The external elements for the identification of the platform of the integrated educational brand of a higher educational institution are as follows: name, logo, graphic, slogan, form, colour or colours, sounds (anthem), movements – all constituents forming the final image of a higher educational institution that involves work over the formation of elements of corporate culture and corporate identity, the search for a productive strategy, own identity and the benefits of educational activity, which in the future will turn into stable values which will provide a long-lasting stable associate perception by the target audience (Lavlok K., 2005). Promotion of the integrated educational brand of a higher educational institution involves the use of traditional marketing tools, the complex of which is aimed at creating own favourable image in order to form the competitiveness of a higher educational institution. The system of marketing tools in this context is considered as educational marketing. The sphere of application of educational marketing is extremely wide. In general, it can be defined as the educational market where there is a production, demand and supply of a special type of product – educational programs, courses, textbooks, etc. There is a difference between the marketing tools of the economic and educational environment, but in general the channels of promotion are traditional. When forming a complex of elements of an integrated educational brand of a higher educational institution, such an important direction of communication activity should be taken into consideration as definition and satisfaction of the informational needs of teachers, employees, current students and other persons in the internal environment because in turn they are also channels for the transmission of information to the target audiences (Kotler F., 2011). So, it can be concluded that in order to achieve the goals, the higher educational establishments are productively employing various communication means and their combinations, which ensure the simultaneous disseminating and obtaining a wide range of diverse and necessary information. In the process of studying the communication activities of higher education institutions, the "deep treasure" of the peculiarities of integrated

marketing communications was also focused on. Thus, it has been established that the distinctive features of integrated marketing communications at a higher educational establishment are:

- a conscious marketing activity of an educational institution in a competitive environment (which, accordingly, has its own goals and nature of persuasion and aims at achieving tactical and strategic objectives);
- definition of not only educational goals and strategic tasks, but also forms and tools used both simultaneously and consistently in the process of communication and are mutually agreed;
- provision of the ways to receive feedback and its availability (in which the response of the recipient of information is simultaneously a signal for further actions of the higher educational institution);
- multilevel nature of communication, the implementation of which includes successive stages (levels);
- the possibility of calculating the economic effect of communication activities (which is a distinctive feature associated with the economic nature of marketing communication);
- economy of the communication budget due to a thorough approach to the selection and coordination of elements of integrated marketing communications.

Thus, given the distinctive features of integrated marketing communications in the "modelling" process of the platform of the integrated educational brand of a higher education institution, it is finally appropriate to use only those combinations of integrated marketing communication tools that are best suited for productive achievement of strategic goals; the choice and intensity of the use of a complex of communication elements are important not only for the higher educational establishment, but for all other members of the communication process.

Using a systematic approach in selecting the channels for promoting a brand of educational service or a brand of a higher education institution as a resource in consumer competition, the integrated educational brand of a higher education institution will strengthen the authority and trust to this higher educational institution.

3.2. Research of Introduction Productivity of Integrated Marketing Communications in Activities of Higher Educational Institutions

The integrated educational message within the platform "modelling" for the integrated educational brand of a higher education institution will enable to achieve the goals with greater productivity by providing accurate and understandable information to the target audience. In terms of promoting an integrated educational brand with advertising tools, the brand acts as an agent of influence on consumers. It is the carrier of psychological, cultural, ideological characteristics that make it possible to consider the capital of an integrated educational brand of a higher educational institution as a source of innovation in the field of education management. The development of an integrated marketing communications system in the context of the platform "modelling" for the integrated educational brand of a higher education institution is one of the final stages of creating a brand that includes:

1. Media planning (provides the contact of the target audience with an advertising message).
2. Production of advertising products.
3. Placement of advertising products in communication channels.
4. Integrated "loyalty programs".

It should be noted that consumer loyalty to a higher educational institution has certain features related to the length of repeated addressing to it (in Ukraine, this is actually connected with the periodicity of the admission campaign to higher educational institutions).

The formation of a loyalty vector by a customer of educational services is the first impression on the contact with a higher educational institution which has credibility. Such a situation should be supported throughout the whole period of cooperation with a higher education institution. It stimulates a potential consumer of educational services to choose one or another institution of higher education and promotes the advice to other consumers of educational services. Loyalty of consumers of educational services at a higher educational institution is supported by the "modelling" of a holistic concept of the integrated educational brand of a higher educational institution. There are currently around two dozens of approaches to assessing the value of a commercial brand in the world, but based on a variety of techniques, there is a number of similar indicators: brand history; stability of situation in the market; coverage share of domestic markets; costs for support of advertising; legal protection, etc. (Sharkov F.I., 2006). However, the brand is an intangible asset of a higher educational institution (Rudelius V., 2005). Creating and promoting an integrated educational brand of a higher education institution is an educational innovation that helps to create and maintain the brand value through the use of integrated marketing communications, which increases the productivity of its promotion. Therefore, the creation of a powerful integrated educational brand of a higher education institution is not simply a combination of a combination of technologies, but the systemic advancement of the educational services at the market and the permanent impact on potential consumers of educational services. Scientific and educational activities of the higher educational institution in conjunction with the "modelling" of the integrated educational brand of the higher educational establishment creates its unique image, which promotes its strengthening and effective promotion in the market. In addition, there is a direct correlation between the integrated educational brand of a higher educational institution, commercial and academic success. That is why the modelling and continuous improvement of the platform of the integrated educational brand of a higher educational institution in the systems of marketing communications of a higher educational institution also have a strategic importance. In addition, it is important to distinguish the categories of "brand identity" and "brand image" because the image is how the brand is perceived, and identity is how it should be perceived. Associative perception is crucial for both concepts, and it is the basis for the communication process, the relationship between the brand and the consumer of educational services (Sharkov F.I., 2006). The difference is in the degree of coincidence between the expected and received perceptions, the task of the brandologists is to make this difference minimum that can be achieved through continuous monitoring of the market environment, conducting a consumer survey, audit and correction of the brand (Serkova E.V., 2012). Thus, the concept of identity of an integrated educational brand of a higher educational institution is related to its subjective perception by consumers of educational services. The positioning of a higher educational institution in the market of educational services also takes into account the geographical location of the target segment (finding and occupying a free niche of educational services, or competing in the existing one) and the presence of a competitive advantage. The task of positioning is to create competitive advantages for a higher educational institution. The geographic segmentation of the modern market is also a productive resource in the platform "modelling" of the integrated educational brand of a higher educational institution and is characterized by the emotional congeniality of the group of consumers, which provides general psychographic features and becomes a distinctive feature of modern segmentation. Therefore, the presence of a working platform of the brand and its clear positioning in the market create conditions for developing a strategy for managing the integrative educational brand of a higher educational institution. Thus, if the content of the strategy concept changes under the influence of the economic development of society, then the traditional approaches to understanding the strategy of platform "modelling" for the integrated educational brand of a higher educational establishment must constantly change and improve.

The specific feature of integrated educational branding of a higher educational institution, the strategy of "modelling" its platform, development, advancement in the market of educational services, its advantages (as the main tool for creating its stable associative perception) make up its content, and the external identifiers of the platform of the integrated educational brand of the higher educational institution (which make it possible to distinguish a brand by external features among its competitors) make up its content load and external appearance. The process of constructing a platform for the integrated educational brand of a higher educational institution and directly the very brand of a higher educational institution as the main source of marketing communications at a higher educational institution is the key element in achieving the strategic goal of commercial success by an educational institution during its operation in market conditions.

4. CONCLUSION

At the current stage of development of the market for educational services in Ukraine and abroad, the successful functioning of national higher educational institutions requires the full orientation to a specific consumer of educational services with long-term relationships, rather than to individual segmented consumer markets. Improving the level of educational services and the competitiveness of higher education institutions in modern conditions is largely possible due to the detailed study and implementation of innovative branding technologies for the effective management of its potential in practice in the educational sphere. The stable competitive position of the institution in the market of higher education is provided by integrated marketing communications as the only functional area where all means of marketing communications are coordinated, which is based on the use of a single integrated educational brand of a higher educational institution. It should be noted that the productive integrated marketing communications play a crucial role in the successful administration of an educational institution and significantly affect the importance of its competitive position in the domestic market of educational services and in other countries. The application of the integrated approach to marketing communications will make it possible to make the "economical" marketing activities of the higher educational institution actual. Despite the fact that branding technology has not been massively introduced in Ukraine, there are already competitive brands in the market for educational services, and not only on domestic scale, but also in the scope of the world educational space. The integrative educational brand of a higher educational institution ensures the efficiency in the implementation of important educational tasks. The platform "modelling" for the integrative educational brand of the higher educational institution promotes the consumers of educational services to make their choice balanced and correct, and what is most importantly, comfortable and productive. Moreover, the formation of an integrative educational brand of a higher educational institution adds the confidence in the future to the educational institution by stabilizing all business flows, minimizing the probable financial and other risks and costs for the development and further implementation of new projects. The need for an integrative educational branding of a modern higher education institution is due to competition between higher education institutions for qualification staff, consumers, and public funding. The integrative educational brand is the source of marketing communications for a higher education institution and is a kind of "subject" in the educational market which offers and promotes its "intellectual property product" in the form of educational services and educational product, brand-persons, brand-events, brand-organizations and others through the establishment of communications with consumers by using the optimal system of integrated marketing tools and technologies. The "modelling" of the platform for the integrative educational brand of a higher educational establishment provides the country with innovative development, economic independence and security of the country, develops its great economic potential.

LITERATURE:

1. Abalmazova, M. (2013). Branding in Sphere of Banking Services and Formation of Brand-Oriented Product. *Marketing and Finance*, No. 1, pp. 4-11.
2. Bekker, E., Burdelova, T., Yudanov, A. (2012). *Brand and Economic Sustainability of Higher Educational Institution: Monograph*. Moscow: KNORUS.
3. Hryshchenko, I., Krakhmalova, N. (2012). Tools and Forms of Marketing Communication in the Market of Educational Services. *Effectiveness of Organizational and Economic Mechanism of Innovative Development of Higher Education in Ukraine*. Kyiv: Bulletin of KNUTD, No. 4, pp. 298-307.
4. Zavorodnia, T. (2010). *Global Brands in Modern Marketing Technologies: Abstract of Thesis*. Kyiv.
5. Kotler, F., Karen, F., Fox, A. (2011). *Strategic Marketing for Educational Institutions* [translated from English]. Kyiv: UAM, Khimgest Publishing House.
6. Krasnyuk, I. (2013). *Marketing Communications: Textbook*. Moscow: INFRA-M.
7. Lovelock, K. (2005). *Marketing of Services: Personnel, Technology, Strategy*, 4 th ed. [Translated from English]. Moscow: Williams Publishing House.
8. Makashev, M. (2004). *Brand: Study Guide for Universities*. Moscow: UNITY-Dana Publishing House.
9. Makasheva, Z., Makashev, M. (2010). *Branding: Textbook*. St. Petersburg: Piter.
10. Rotov, A. (2010). *Formation and Use of Personal Brand in Marketing System: Abstract of thesis*. St. Petersburg.
11. Rudelius, V., Ozarian, O., Vynohradov, O. et al. (2005). *Marketing. Textbook*. Kyiv: Educational Centre "Consortium for Improvement of Management Education in Ukraine".
12. Serkova, E. (2012). Branding in Higher Professional Education. *Materials of the XV All-Russian Forum of Young Scientists with International Participation in the Framework of the III Eurasian Economic Forum of Youth*. Ekaterinburg, pp. 189-192.
13. Sinyayeva, I. (2012). *Integrated Marketing Communications: Textbook for University Students in Specialties of Marketing, Advertising, Public Relations*. Moscow: UNITY-DANA.
14. Tsipurynda, V. (2013). Factors of Formation of Intellectual Capital. *Bulletin of KNTEU*, No. 2, pp. 18-28.
15. Schultz, D., Tannenbaum, S., Lauterborn, R. (2004). *New Paradigm of Marketing. Integrable Marketing Communications* [Translated from English]. Moscow: INFRA-M.
16. Sharkov, F. (2006). *Modern Marketing Communications. Reference Dictionary*. Moscow: Alfa-Press Publishing House.

MONITORING OF ARCHITECTURAL MONUMENT CONTINUES

Yurkovsky R.G.

Ph. D. in Engineering Science, Professor at Odessa State Academy of Civil Engineering and Architecture, Ukraine

Nakhmurov O.N.

Ph. D. in Engineering Science, Professor at Odessa State Academy of Civil Engineering and Architecture, Ukraine

Shishkalova N.Y.

Senior lecturer at Odessa State Academy of Civil Engineering and Architecture, Ukraine

Zakharchuk V.V.

Assistant at Odessa State Academy of Civil Engineering and Architecture, Ukraine

Kolomiets N.P.

*Assistant at Odessa State Academy of Civil Engineering and Architecture, Ukraine
geodesy.odaba@gmail.com*

ABSTRACT

In the center of the city Odessa at the intersection of Deribasovskaya and Preobrazhenskaya streets there is an architectural monument of the XIX century - "Passage". Due to changing technogenic and natural factors, the "Passage" building was constantly undergoing minor deformations. However, since 2009 the intensity of deformation of the building has increased. To study deformation processes, geodesic monitoring was organized to study the draft of the building. To quantify the sediment of the Passage building, a method of high-precision geometric leveling with the beams of the second class program with a precision electronic level Dini 12 and a bar-code strip was used. Analysis of the results of observations served as the basis for an objective identification of the alleged causes of sediment. The main cause of the deformations was the local soaking of the soil of the base of the building as a result of water leakage from the damaged (spoiled) water-bearing communications that pass from Deribasovskaya street through the entrance to the "Passage". After the reconstruction of water-bearing communications, deformation processes ceased. This made it possible to give recommendations on eliminating these causes and ensuring the normal operation of the building in the future. During the reconstruction of the street Preobrazhenskaya in 2017, the road surface was lifted to a depth of 1-1.5 meter, and the work was carried out by heavy road machinery and jackhammers. At the same time, reinforced concrete was started to reinforce the foundations of the "Passage" interior, also with the use of jackhammers in conjunction with existing foundations. The appearance of new cracks is presumably a consequence of these vibrational processes. Recent observations of the sediments of the building, carried out in March 2018, found discrete subsidence of up to 12-30 mm for almost half a year. Simultaneously, the electronic total station Nivo measured the roll of the outer walls of the main facades of the building. Calculation of the rolls was carried out by the method of coordinates. Roll in the direction of Preobrazhenskaya street reaches 311 mm.

Keywords: *water-bearing communications, geodetic monitoring, geometric leveling, deformation processes, roll, building sludge*

1. HISTORICAL AND CULTURAL VALUE OF THE ARCHITECTURAL MONUMENTS

The ancient building of the Odessa "Passage", was built in 1898-1899, located in the city centre (on the corner of Preobrazhenskaya and Deribasovskaya streets) and one of the most beautiful buildings in the city. Persist the postcards (pic. 1.2), published before 1901, which are eloquently evidencing that the Passage became the pearl of the Odessa.



Pic. 1: The building of the "Passage" on postcards until 1901



Pic. 2: General view of the "Passage" building in the early 19th century

Pictures taken before the fire in 1901, as there a central tower on the roof. In the result of the fire, this tower on the roof was burnt and was not restored (pic. 3)

Picture following on the next page



Pic. 3: Building "Passage" after the liquidation of the consequences of the fire

On the building have a large number of sculptures and stucco (pic. 4-5), the main of them sculpture of Mercury protector of the trade and two sculpture of Fortune. Talented Polish architect L.L. Vlodek balanced harmoniously combined several architectural styles: modernized eclecticism, mixed style of Baroque and Renaissance, eclecticism and late modernity (interiors) and even the Moorish style (arches). At the time of commissioning, "Passage" was equipped with the most modern standards for that time - electric lighting, which was provided by own power station, steam heating, telephones, elevator.



Pic. 4: Opened cracks on the facade of the "Passage"

The inner courtyard of the hotel is closed by glass roof and creates a unique atmosphere of the European city with the refinement of architecture and sculptural compositions, inside of the hotel there is a whole street with shopping rows (pic.5)

Picture following on the next page

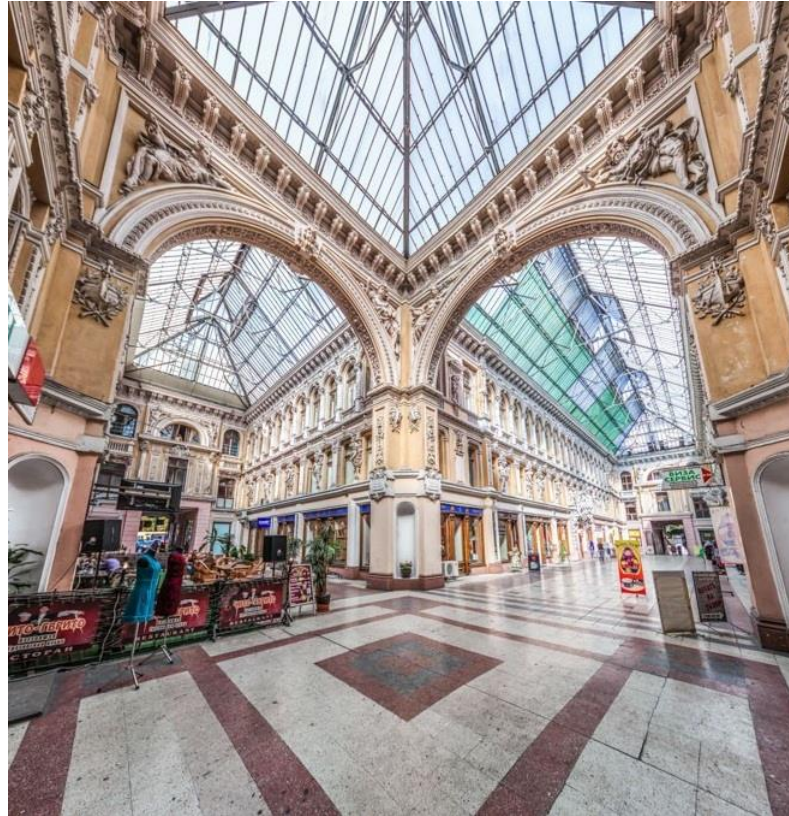

Pic. 5: The modern view of the gallery "Passage"



Pic. 6: Sculptural groups symbolizing abundance

Before the revolution in "Passage" were the most solid shops of the city: jewelry, perfume and haberdashery, gramophones and musical instruments, gastronomic, crockery, book and postcards. Besides, "Court Passage" Passage" was in the building of "Passage". In the years of the NEP, apart from the hotel and shops, the building housed various Soviet institutions. One of the most famous and the longest (about 100 years) that existed without changing the profile of the "Passage" element was the "Central Gastronome" (located in the premise on the first floor at the corner of Deribasovskaya and Preobrazhenskaya streets). The profile of the retail space store was changed only at the beginning of the 21st century. Nowadays, there is jewellery store and located in the hotel complex and shopping rows.

2. ARISEN PROBLEMS

In 2017, in the old building of the Odessa's "Passage", after reconstruction of water-bearing communications and foundations in 2015, reappeared the cracks. Presumed cause is soaking the loess-like soil of the base of the building and arising due to their uneven precipitation. [3]

3. ANALYSIS OF RECENT ACHIEVEMENTS AND PUBLICATIONS, IN WHICH PRINTED THE SOLUTION OF THESE PROBLEMS

The first visual deformation cracks of the "Passage" walls were detected in 2009. By the department of engineering geodesy of Odessa State Academy of Civil Engineering and Architecture on the perimeter of the building were laid deformation sedimentary marks (pic. 7) and were made 4 cycles of high-precision geometric levelling with short beams of sighting by the electronic level DINI 12 according to the program of II class of accuracy. From the analysis of the results, it was concluded that significant local sediments (20-22 mm) of grades 12, 13, 16, 17 are caused by soaking the soil of the foundation of the building from obsolete damaged water-bearing communications, which run from ul. Deribasovskaya through the entrance to the "Passage" After their reconstruction, the fourth leveling cycle showed no further build-up of the building, and a mathematical-statistical analysis of the results confirmed that, in the absence of additional aggressive influences, the sediment would end in May 2019, increasing by 1 mm. However, in 2016-2017 years the capital reconstruction of the road surface and communications of the street of Preobrazhenskaya with excavation up to 1.5 m (pic. 8-9), which probably influenced condition of the building. [4-7]

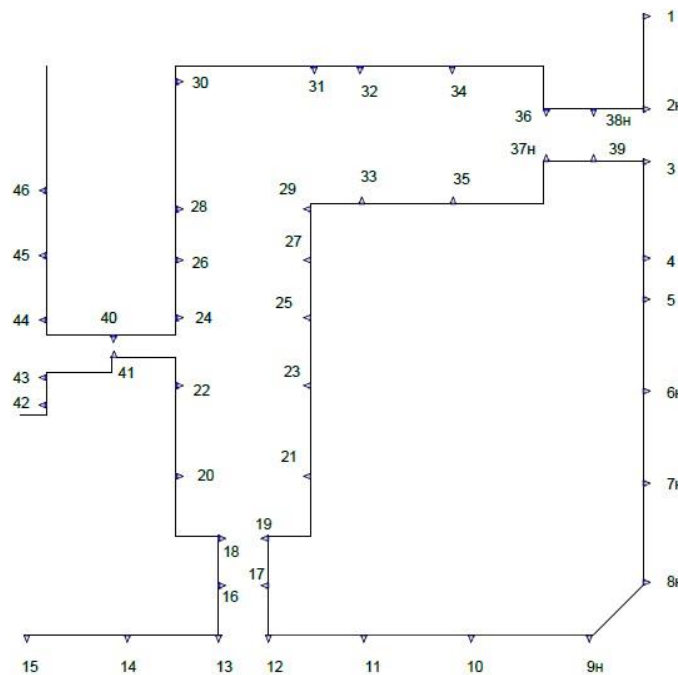

Pic. 7: Deformation marks arrangement

Picture following on the next page



Pic. 8: Reconstruction of the Transfiguration Street in 2017

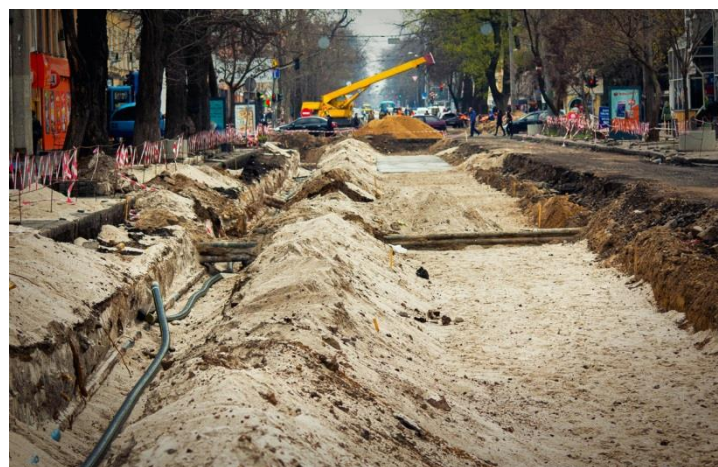

Pic. 9: Replacement of engineering networks near the "Passage"

4. PURPOSE OF RESEARCH

For a qualitative assessment of new deformations, finding out their causes, sources, and making recommendations for the elimination of possible disruptions, continued geodetic monitoring performed in 2009-2017.

5. SUMMARY OF THE BASIC RESEARCH MATERIALS

Geodetic monitoring continued with the observation of sediments of deformation marks and rolls of the exterior walls of the building. The measurement accuracy of the sediment was established in accordance with requirements with an average square error not exceeding ± 2.0 mm. This value is the starting point for selecting the observation method, the instruments and calculating the accuracy of determining the excess at the station. To determine the building sludge with an average square error of $m_n \leq \pm 2,0$ mm, the method of high-precision geometric levelling by short beams of sight up to 25 m was used in accordance with the program of II class of accuracy using the high-precision electronic level DINI 12 and bar-code strip. Three base-points were used as a fixed base [4-9]. From the obtained results it follows that from August 26, 2017 to 07.03.18 the building sludge was practically absent with the exception of grades 12, 13, 16, 17, 18, 19 from 3 to 9 mm, M37 and M38 - 12 mm and M29 - 30 mm. There are no regularities in the development of precipitation, except that the first two grades are in the sensitive structures of the building-arches, and the M29 sediment is probably associated with reinforced concreting to strengthen the foundations of the "Passage's" interior with the use of jackhammers in conjunction with existing foundations [14-15].

6. DETERMINATION OF THE SLOPE

Building tilt were measured instrumental by electronic tachymeter series Nivo. The rolls of the walls were calculated by the coordinate method. The technical task was to determine the roll of the walls of the main facades from the Deribasovskaya street and Preobrazhenskaya street. In connection with a significant number of architectural elements, the challenge was to the determine the plane of the walls in terms of both height and height. The definition of roll of the building was carried out in height and in four levels. Due to the lack of measurement drawings, the distance between points along the length of the building was taken in such a way that the plane of the wall was designated. From the results obtained, it follows that the deviation of the walls from the side of Deribasovskaya ranges from 0 to 125 mm. At the same time, there are no regularities in the deviation of the building walls. The maximum deviation of the wall along the vertical is 125 mm. A significant variation in the deviation of the walls in the planned position takes place along the facade from the side of the Preobrazhenskaya Street. The deviation of the wall varies from 0 to 311 mm in the level of the fourth floor. Part of vertical deviations the middle of the building wall from the Preobrazhenskaya street in pictures 10.

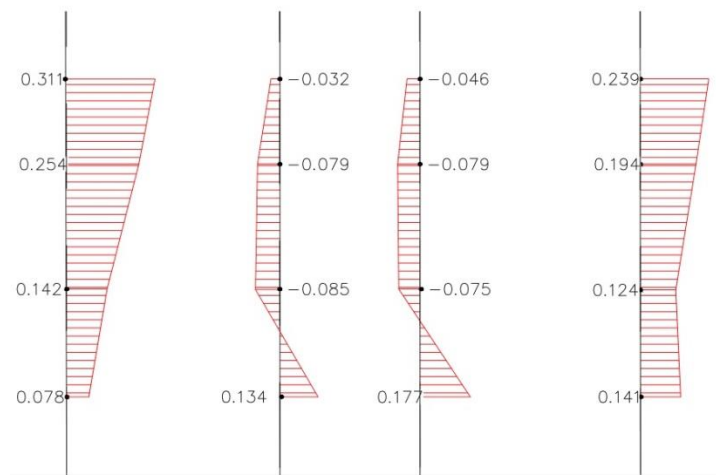

Pic. 10: Part of vertical deviations the middle of the building wall from the Preobrazhenskaya street

7. CONCLUSIONS AND RECOMMENDATIONS

1. Precipitation of the building during the last cycle of geodetic observations in the period from 26.08.2017 to 07.03.2018. develops unevenly and is the range from 0 to 30 mm. There is no possibility to establish the reasons for the development of the uneven deformation of the "Passage" building. At the time, the development of uneven deformation can be influenced by:

- change in groundwater level including under the influence of reconstruction of the street of Preobrazhenskaya;

- the impact of technogenic dynamic processes;
- the influence of dynamic processes in the process of reinforcing foundations.

2. Due to the fact that the interval between the penultimate and the last cycles of geodetic measurements is 6 months, it is not possible to establish the development of deformation in time. In this regard, and it is necessary to perform at least three more cycles of geodetic measurements with an interval of 1 month, in order to reveal the regularity in the development of the draft of the building in time.

3. The maximum deviation of the roll from the side of the Preobrazhenskaya Street is 311 mm. In addition, the value of the roll is within the limits permitted by regulatory documents. [8]

4. It is advisable to install deformation marks inside of the building as an arch and as an along the perimeter of the exterior wall of the building from the east side.
5. The building of the "Passage" requires constant geodetic monitoring during the whole period of its reconstruction.

LITERATURE:

1. Gubar Oleg. (2014). Architecture of Odessa: History. Passage. Received on 05/17/2108 <http://archodessa.com/all/passage/>
2. Paramonov Yuri. (2012). About Odessa with love! / Articles' Catalog: Passage. Received: 05/17/2018 of <http://picasaweb.google.ru/vonomarap/mHNNH02?feat=directlink>
3. Nakhmurov Oleksandr, Kolomiets Natalia. (2016) Providing geodetic monitoring of the draft of buildings and structures erected on loess subsidence soils. Materials of the All-Ukrainian Scientific Conference: Geodesy and Land Management in the Southern Region: Current Status and Development Prospects. Odessa, 2016, 22-24 p.
4. Stukalsky Vladimir, Shargar Elena. (2011). Fundamentals of engineering geodesy. Tutorial. Odessa, 2011, 236 p.
5. Voitenko Stepan. (2012) Engineering Surveying. Textbook: 2nd edition., Revised and enlarged. Kiev. Knowledge, 2012, 574 p.
6. Yurkovsky Rostislav. (2006) Engineering geodesy. Tutorial. Odesa, 2006. 202 p.
7. Tretenkov Valery. (2016) Mathematical processing of geodetic measurements. Part 2, Fundamentals of the application of the method of least squares: A manual for students in higher educational institutions training direction: Surveying and land management. Odesa.
8. Gladkikh Igor, Nakonechny Vitaly, Nakhmurov Oleksandr, Pinul Ekaterina, Rostislav Yurkovsky. (2016). Geodetic monitoring of the architectural monument. Bulletin of the Odessa State Academy of Construction and Architecture, issue No. 61, Odessa, 2016, pp. 79-88
9. Demchenko Vlad, Zakharchuk Vita, Nakhmurov Oleksandr, Shyshkalova Nataliia, Yurkovskyi Rostislav. (2018) Monitoring architecture monument. International periodic scientific journal: A scientific look into the future! Issue No.9, 2018, Volume 1, Engineering Sciences, Odessa, Kuprienko SV, 2018, pp. 64-70.
10. Zakharchuk Vita, Nakhmurov Oleksandr, Shyshkalova Nataliia, Yurkovskyi Rostislav. (2017). Geodesy on guard of the monument of architecture. Problems of theory and history of architecture: ISSN 2519-4208. Collection of scientific works, vypusk 17. Odesa, 17 p. 194 -200
11. Zakharchuk Vita, Nakhmurov Oleksandr, Shargar Elena, Shyshkalova Nataliia, Yurkovskyi Rostislav. (2017). Building Settlement Prediction. International periodic scientific journal: A scientific look into the future! Issue No. 6, Volume 5, Geography, Agriculture, Biology Medicine, Veterinary Medicine and Pharmaceuticals Safety Legal and Political Sciences Art, Architecture and Construction Physics and Mathematics, Odessa, Kuprienko SV, 2017, pp. 76-80
12. State building standards in Ukraine. (2010). System for ensuring the accuracy of geometric parameters in construction, SBS V.1.3-2: 2: 2010, Geodetic works in construction. Kyiv, Minregionstroy of Ukraine, 2010.
13. State building standards in Ukraine. (2009). Construction objects and industrial products for construction purposes. Foundations and foundations of buildings and structures. Foundations and foundations of structures. Basic design points. SBS V.2.1-10-2009, Kiev, Ministry of Regional Development of Ukraine, 2009. 90 p.

14. Zakharchuk Vita, Kolomiets Natalya, Nakhmurov Alexander, Natalia Shyshkalova, Rostyslav Yurkovsky, (2017). Monitoring in dense buildings. International periodic scientific journal: Scientific view to the future! Issue # 14, Volume 1, Minsk, Belorussia, pp. 44-51.
15. Voitenko Stepan (2005) The use of the concept of uncertainty in the processing of the results of geodetic measurements. Collection of scientific works: Modern achievements of geodesic science and production. Lviv, Publisher of the University of Lviv Polytechnic, 2005.

DEVELOPMENT OF DEVICE TECHNOLOGY ANTI-FILTRATION SCREEN WITH USE SCREW EQUIPMENT

Alexander Meneyliuk

Odessa State Academy of Civil Engineering and Architecture

Anatoly Petrovsky

Odessa State Academy of Civil Engineering and Architecture

Alexander Borisov

Odessa State Academy of Civil Engineering and Architecture

Stanislav Kyryliuk

Odessa State Academy of Civil Engineering and Architecture
kirilstani@ukr.net

ABSTRACT

The problem of protecting territories from flooding is relevant for many decades. An effective way to protect buildings and structures from groundwater is to install vertical anti-filtration screens. But not always waterproof is at the reach of depth, and the construction of a horizontal screen will create additional difficulties. The arrangement of a horizontal screen under an existing building will require a large area of production, the implementation of labor-intensive soil development or the use of expensive horizontal directional drilling. It will also require the interface of the horizontal and vertical parts of the anti-filtration shield to provide protection from groundwater. The technology of the device of the conjugate anti-filtration screen under existing buildings and structures, which are located in areas subject to flooding, has been developed. In the article, the use of well boring under the slope and the device of conjugate anti-filtration screens using the developed screw equipment are considered. Drilling of inclined guide holes is carried out under the existing building at an angle, which ensures further coupling of the anti-filtration elements of the screen. Screw equipment is usually used for the arrangement of vertical wells and the auger is directed along the well being developed. In the developed technology the auger is located perpendicular to the guiding wells and is used for the development, transportation and mixing of soil with solutions. Anti-filtration screens, made with auger equipment, are formed due to intersecting elements, in the form of panels, which are formed by mixing the soil with cement mortar. A technological plan for the production of works to protect against flooding of existing buildings according to the developed technology is developed. The main technological processes, materials and equipment for the production of works are presented.

Keywords: *anti-filtration screen, auger equipment, flooding of territories, drilling of wells*

1. INTRODUCTION

Industrial, urban, hydraulic engineering and meliorative construction caused an increase in the level of groundwater. As a result, underground water floods the sites of industrial enterprises, territories of cities, large settlements. The construction of anti-filtration screens is effective for protecting buildings and structures from groundwater. Vertical screens, join with the water repellent, overlap the filtering area [1]. If the water retainer is in inaccessible depth, then the construction of a vertical anti-filtration shield to protect existing buildings and structures from flooding is not appropriate.

2. ANALYSIS OF RECENT RESEARCH AND PUBLICATIONS

Screw drilling is a type of rotary drilling of wells, in which the destroyed rock is delivered from the well to the surface by a screw, a drill pipe with a steel band wound on it. The destruction of the rock at the bottom of the well during auger drilling occurs by cutting and loosening the rock with a paddle drill bit [2]. The screw of the drilling rig (Figure 1) is directed along the developed well and is used for development with transportation of soil. Modern technologies allow feeding a hardening solution through a screw into the well cavity [3].



Figure 1. Drilling rig

The construction of an anti-filtration screen along the building using the above drilling rig is labor-intensive. Drilling wells one after another with mating is done with many repetitions of operations or an increase in the number of installations. More efficient is the drilling of wells of rectangular cross-section. An alternative design of a drilling tool with a curved working surface is proposed at the Kazakh Polytechnic Institute. The bit is made in the form of a truncated sector of a flat disk (Figure 2).

Figure following on the next page

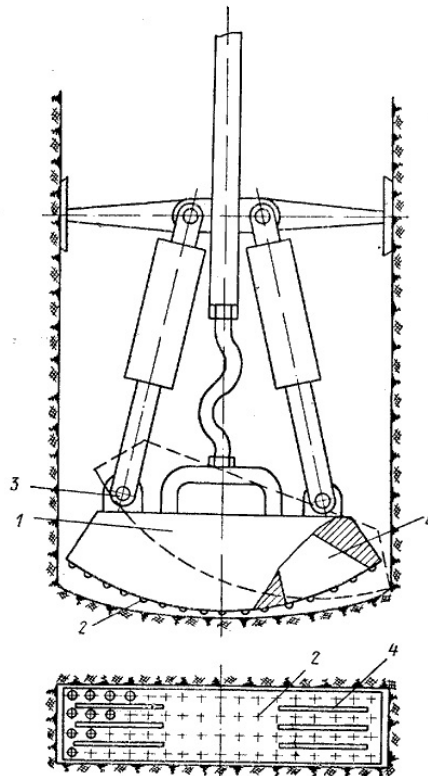

*Figure 2. Drilling tools for the formation of wells of rectangular cross-section:
1 - body; 2 - teeth; 3 - hinges; 4 - slits for flushing liquid*

The working surface of sector 1 is equipped with carbide-tipped teeth 2. On the truncated part of the sector there are hinges 3 connecting the bit with a mechanism of cyclic action, for example an eccentric type rotated by drill pipes. The destruction of the rock at the bottom of a rectangular well occurs with periodic rolling of the bit along the face. In the bit body, slots 4 are provided for passage of the washing liquid [4]. The drilling tool is designed to form vertical wells of rectangular cross-section that can be used to construct a vertical screen with a water seal. In the absence of waterproof at an accessible depth, the use of this tool is not advisable.

3. RESEARCH RESULTS

To protect existing buildings and structures that are subject to flooding, a technology has been developed for constructing a conjugated anti-filtration screen using screw-type equipment. In the developed technology the auger is located perpendicular to the guiding wells and is used for the development, transportation and mixing of the soil base with hardening solutions. Drilling technological wells is done in two stages with minimal impact on the foundation of the existing building. In the first stage, wells are drilled at an angle along an existing building or structure (Figure 3). The required slope of the wells is determined taking into account the depth of foundation and the width of the section, which is possible for deflection. The number of wells depends on the width of the element and the geological conditions of the anti-filtration screen and varies from 1.5 to 2 meters.

Figure following on the next page

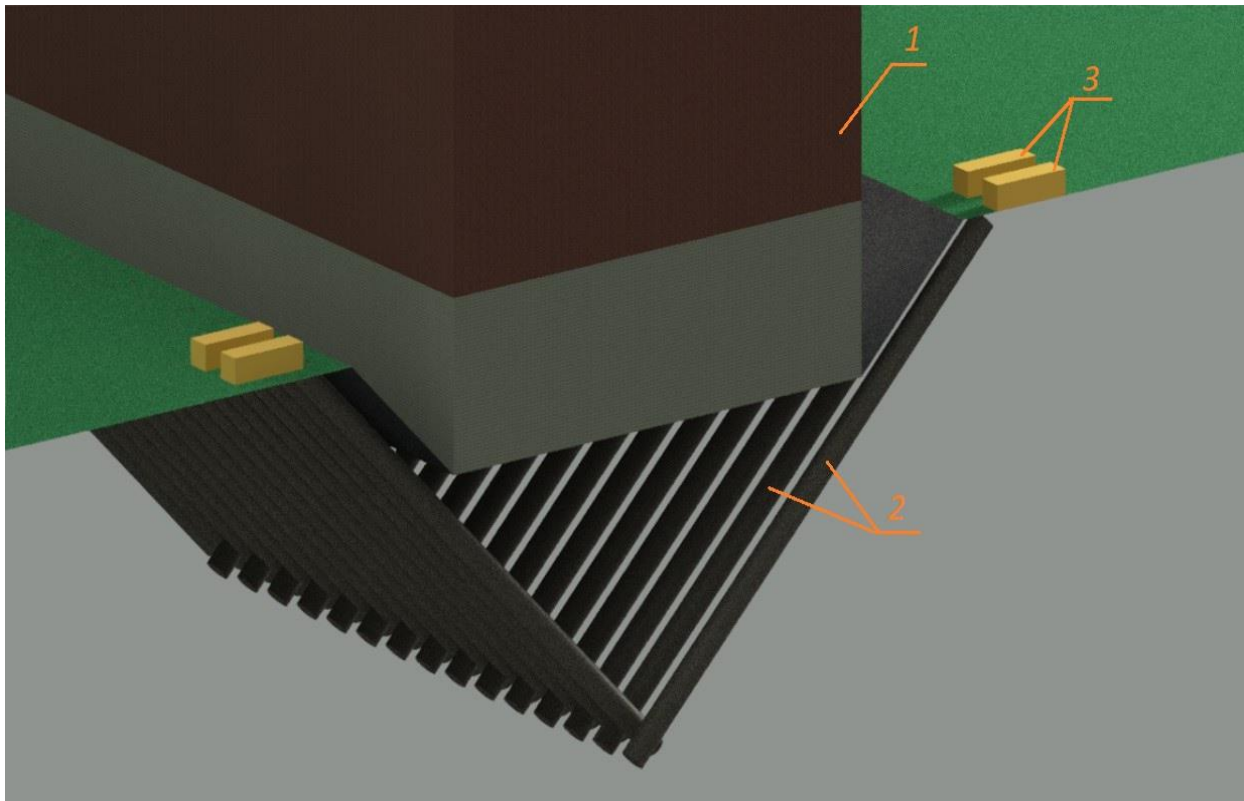

*Figure 3. Construction of an anti-filtration screen:
1- existing building; 2- inclined wells;
3- drilling rig*

The depth of the technological wells is determined taking into account the intersection of two opposite planes in the lower level of the anti-filtration screen and their mutual interfacing. The arrangement of the wells of the two inclined planes, relative to each other, is expediently performed with ligation to ensure their monoliting when crossing. At the ends of building, the anti-filtration screen is arranged with the help of vertical screens, which are interfaced with the inclined planes described above. Vertical screens complete the creation of a continuous anti-filter screen, which takes the form of a triangular prism. Anti-filtration screens are formed due to intersecting panels obtained as a result of mixing of the ground with hardening solutions (bentonite, cement, liquid glass, etc.). With direct drilling, the developed soil is transported by a bi-directional screw (Figure 4a) from the center to the guide wells and pumped to the surface by pumps. As a result, a flat slit is formed between the guide holes. The hydraulic motor rotates the auger, which is attached to the rig shafts. After reaching the depth of drilling, a hardening solution is fed through the rods through the rods, which fills the formed slot during the backward drilling (Figure 4b). The hydraulic motor rotates the bidirectional screw in the opposite direction and mixes the developed ground with the solution. The drilling rig evenly raises the rotating auger, using the guide rods.

Figure following on the next page

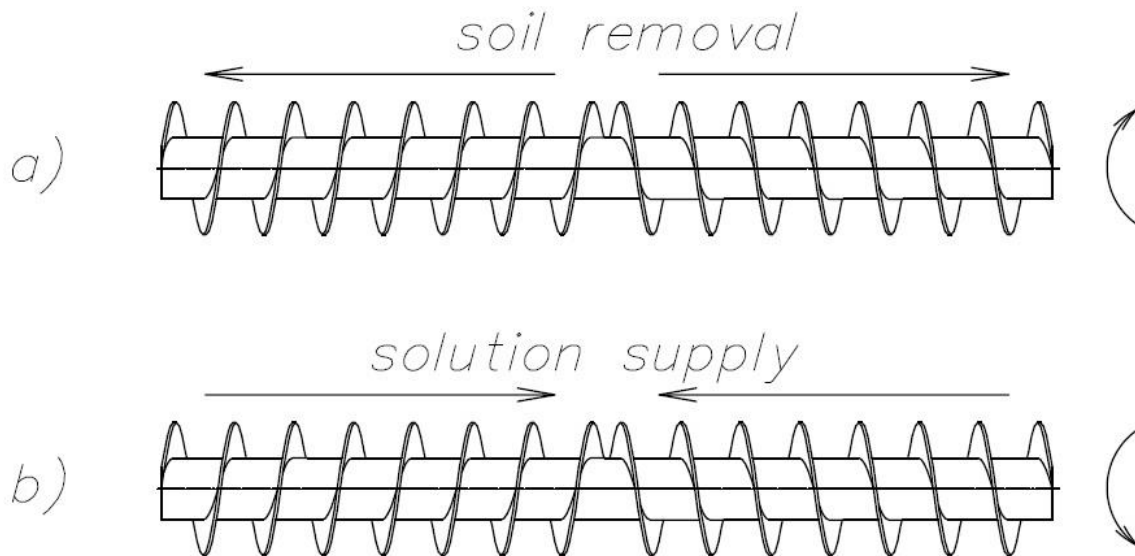

*Figure 4. Bi-directional screw:
a – soil removal; b – solution supply*

Next, the installation moves to the next design position and the operations for the construction of the screen element are repeated. The site for the construction of the next element is passed through one well to the design strength of the element. The second stage of the construction of the anti-filtration screen follows after the hardening of the solution of the first stage. This is necessary to transfer loads from the foundation of the existing building. The drilling rig is moved to the position of the missing element and the operation for drilling a rectangular well and filling with a solution is repeated. The transition time to the second stage with the use of cement mortar does not exceed 6 hours after setting [5] to prevent cold seams and ensure the monolithic nature of the screen. After solidification of the solution of the second stage, a monolithic construction with an average thickness of about 15-20 cm is formed. In parallel, work is underway to build two sloping screen planes along the building and vertical screens along the ends of the building in order to minimize the possibility of cold seams of the anti-filtration screen. Work on the construction of the first end vertical screen begins with the beginning of work on the construction of inclined planes, and work on the construction of a second end vertical screen begins before the end of the work on the construction of inclined planes of the anti-filtration screen. The construction of vertical face-to-face anti-filtration screens is carried out according to the developed technology, but without the inclination when drilling rectangular wells. Technological wells are performed vertically to the depth of intersection with the inclined planes of the anti-filtration screen. Creation of anti-filtration elements is performed in turn with passes to minimize the effect of loads from the existing building. Drilling with a bidirectional screw is performed in two guide wells. This creates a cavity for the hardening solution, which is supplied after drilling and creates an anti-filtration element. A set of end elements create an anti-filter screen in the form of a triangle. Ultimately, according to the developed technology, the anti-filtration screen has the form of a prism consisting of two longitudinal inclined and two vertical triangular planes. The planes of the anti-filtration screen are connected monolithically with the holding of temporary technological interruptions. To increase the strength and waterproofness of the screen, the dispersed reinforcement with basalt fiber is used.

4. CONCLUSION

1. Advantages of the developed technology:

- elimination of the need for preliminary excavation, construction of water depletion, maintaining the stability of the walls of excavation, preliminary strengthening of the foundations of neighboring buildings and structures;
- Absence of impact loads, strong noise effects, significant sedimentation of foundations and ground surface elevations;
- the possibility of performing construction work under the foundations of buildings and structures, in weak and water-saturated soils, in cramped conditions, at depths of up to 30 m;
- during the construction of anti-filtration screens, ensure the monolithic joining of adjacent sections - due to their crossing.

2. The developed technology will allow to build a monolithic anti-filtration screen under existing buildings or structures, to protect them from flooding, in soils with unattainable waterproofing.

LITERATURE:

1. Zarubina LP, Protection of territories and construction sites from groundwater flooding / M.: Infra-Engineering, 2017. 212s.
2. Kantovich LI, Khazanovich G.Sh., Machines for mining works / Textbook. - M .: Publishing house "Mining book", 2011. 445p.
3. Badin GM, Sychev SA, Modern technologies of building and reconstruction of buildings / SPb: BKhV-Petersburg, 2013. 288p.
4. Lysenko VM, Sitnikov VD, Sitnikov EV, Drilling tool for the formation of rectangular cross-section / patent № 400699, 1973.
5. Statsenko AS, Technology of concrete works: training. allowance / Minsk: Vysh. shk., 2009. 239c.

ENERGY-SAVING AS A NECESSARY FACTOR OF THE MODERN DEVELOPMENT ON THE EXAMPLE UKRAINE

Kateryna Tiulkina

Odessa State Academy of Civil Engineering and Architecture, Odessa
katetulkina@gmail.com

ABSTRACT

The degree of socio-economic development of any country and the living standard of its population are directly related to the amount of energy consumed. The task of the state economic policy is to form an effective energy saving strategy and to intensify the processes of updating the fixed assets with high-tech energy-saving equipment and technologies. Currently, the ecological situation in Ukraine is difficult. Excessive anthropogenic impact and a high level of technogenic load on its territory testify to this. The situation regarding energy efficiency in the housing and communal services complex remains the most complicated. The energy intensity of GDP in Ukraine is higher than in European countries. The conditions of the EU-Ukraine Association Agreement provide for the introduction of sustainable economic development and the mechanisms of "green" economy. The article presents different approaches to the definition "ecologization of the economy", the essence of energy saving and directions of energy-saving technologies. The study considers the assessment of Ukraine's environmental sustainability through various indicators (Environmental Performance Index, Energy Architecture Performance Index) and its comparison with other countries. The legislative framework and existing state programs on energy saving in Ukraine are considered. In conclusion, on the basis the energy saving potential and of foreign experience in the implementation of energy-saving measures, the main directions of implementation of energy efficiency in Ukraine were identified.

Keywords: *ecologization, energy intensity, energy-saving, environmental sustainability*

1. INTRODUCTION

World experience shows that high energy intensity of the economy combined with the scarcity of its own power base causes numerous problems lowest price competitiveness, the additional burden on the state budget, strengthening of inflation etc. Therefore, today the energy efficiency of industrial production and reduce energy consumption in the housing and communal services is not an issue of economic expediency for Ukraine, but a matter of survival. The works of many Ukrainian and foreign scientists devoted to the study of energy efficiency and energy saving in a market economy: A. Prachovnik, L. Antonenko, V. Rosen, M. Voznyuk, Yu. Bakalin, G. Bagiev, A. Zlatopolsky and other. At the same time, work on identifying directions and ways of optimizing energy supply to stimulate the development in Ukraine should be permanent in view of new types of resources and new program activities.

2. ANTHROPOGENIC IMPACT AND ENERGY INTENSITY

2.1. Anthropogenic impact

Excessive human impact and high anthropogenic impact on the territory of Ukraine due to the presence of complex mining, chemical and energy facilities, a large number of industrial-urban agglomerations and the high population density in industrial and developed regions of the state. For a long time, about 60% of export earnings were provided on the basis of extraction and processing of mineral resources. This leads to the formation of large amounts of waste, polluting emissions to air and discharges into surface water objects. For example, in 2015 emissions of air pollutants in Ukraine made up 4.5 mln.tons. About 63% of it refers to stationary sources of pollution industries.

The density of air pollutants emission on average per 1 sq. km of the territory in Ukraine was 7.8 tons, and per capita - 105.5 kg. [4]. A significant amount of waste from production and consumption and the inadequate level of reuse, recycling and utilization creates real risks for the population and the environment, taking into account the increasing level of pollution of surface and groundwater waste. In 2015 according to the State Statistics Service of Ukraine, the 13,544 enterprises that are covered by statistical observation and households formed 312.3 mln. tons of waste. 98.1% of generated waste (306.2 mln. tons) was formed as a result of the economic activity of enterprises and organizations, and 1.9% (6.1 mln. tons) in households. The peculiarity of the waste structure in Ukraine, due to the raw material orientation of the economy, is the high proportion of mining waste (overburden and mineral products - slimes, tails, etc.) , over 75%. The largest amount of waste is formed at the enterprises of mining and metallurgy, coal, chemicals and energy. In Ukraine, during 2015, 94.4 mln. tons of waste was utilized (recycled), which is 30.2% of the total generated waste, and 1.13 mln. tons was burned. According to the state statistical reporting, 12.5 billion tons of waste has been accumulated in specially designated places or objects and in the active enterprises by the end of 2015. The technogenic load on the territory of Ukraine in 2015 amounted to 21.7 thousand tons per 1 sq. km. Currently, there is no system of effective treatment of industrial and domestic waste in Ukraine, therefore there is a risk increasing their accumulation (7.2 billion tons, or 20-25% by 2030) and increasing surface area required for their storage. The waste management situation is complicated by the lack of necessary infrastructure for the separate collection, sorting and utilization of solid household wastes. In Ukraine, GHG emissions occur in the following sectors set by the IPCC: Energy; Industrial Processes and Product Use (IPPU); Agriculture; Land Use, Land Use Change and Forestry (LULUCF); Waste. The GHG emission structure is shown in Figure 1.

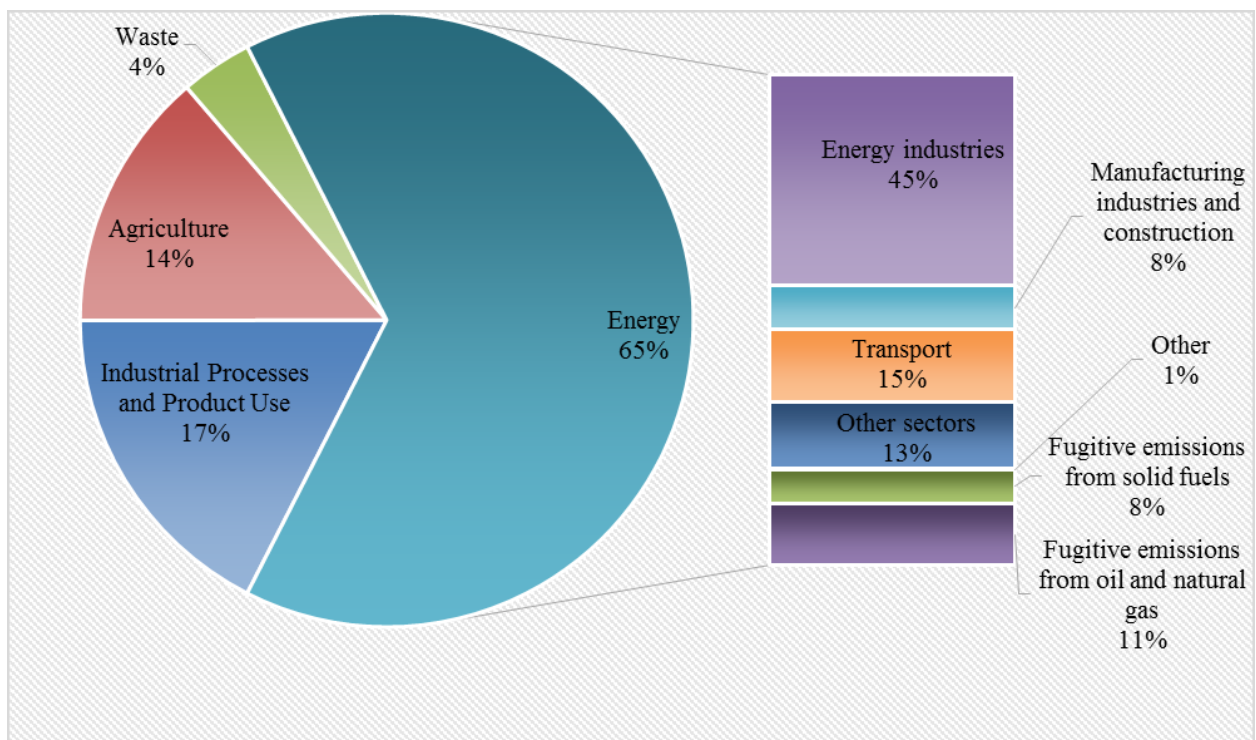

Figure 1. The GHG emission structure in 2016 [5]

The largest GHG emissions in Ukraine take place in the Energy sector. In 2016, the share of this sector accounted for around 65% without the LULUCF sector. About 80% of emissions in this sector account for emissions in the Fuel Combustion category, which include the categories

of Energy Industries, Manufacturing Industries and Construction, Transport, Other Sectors, and Other, as well as 20% - emissions in the category of Fugitive Emissions from Fuels. The share of the Agriculture sector in total GHG emissions without LULUCF was 13.9% in 2016. The major sources of emissions in the Agricultural sector are enteric fermentation and agricultural soils, 24.7 % and 64.4 % of the total emissions in the sector in 2016, respectively. The contribution of the Waste sector in 2015 in total emissions is 3.7%. The main source of CH₄ emissions is landfills of municipal solid waste (MSW), and that of emissions of N₂O - human sewage.

2.2. Energy intensity

Energy efficiency is one of the integral indicators of the economy, science and socio-cultural development of the nation. By this indicator Ukraine is among those states where stagnation of the existing situation can provoke a serious economic crisis with subsequent massive social upheavals. The most complicated energy efficiency is the situation in the housing and communal services complex, where worn-out heating and water supply stations operate with low efficiency and deliver through the same worn-out networks. As a result, energy losses reach 45-50%. For example, in Ukraine the efficiency of thermal power plants with steam turbines is 35% (and in some stations even 25%), the world actively implemented combined-cycle plants with an efficiency of 50-60%. Significant energy costs take place in industrial production, especially in such industries as metallurgy, chemical and petroleum refining industry. Here the energy share in product value is 30-50% and sometimes up to 60%. For the country as a whole, the energy intensity of gross domestic product is almost 3 times higher than in European countries and the world and exceeds the energy intensity of the closest neighbors (table 1). This means that goods manufactured in Ukraine have considerably higher costs compared to the same foreign model.

Table 1: Energy use (kg of oil equivalent) per \$1,000 GDP (constant 2011 PPP)

	2007	2008	2009	2010	2011	2012	2013	2014	2015
World	139.8	137.8	137.4	137.8	134.5	132.6	130.0	126.5	..
European Union	101.1	100.0	98.5	100.3	94.7	94.4	93.1	88.0	86.8
Ukraine	352.6	333.0	332.5	369.0	334.3	322.9	306.2	298.1	..
United States	152.1	148.6	145.3	145.0	141.2	136.0	135.3	134.0	128.2
Belarus	215.5	195.8	185.6	178.6	180.4	184.4	163.2	163.2	..
Bulgaria	180.2	171.5	156.9	158.1	166.9	159.4	145.6	152.0	..
Moldova	261.5	241.7	244.3	251.8	232.0	231.2	189.9	194.9	..
Poland	129.2	125.8	117.7	121.3	116.1	110.5	108.9	101.6	98.4

Source: created of author on base World Development Indicators, Series: Energy use (kg of oil equivalent) per \$1,000 GDP (constant 2011 PPP) [8]

Ukraine's high energy intensity is a consequence of the peculiarities of the structure in the national economy shifted towards more energy-intensive industries, the substantial technological lag of most industries from the level of developed countries, as well as price distortions in the internal energy markets. In terms of the country's dependence on imported energy sources such as gas and oil high energy intensity limits the competitiveness of domestic production and leads a significant burden on the economy.

3. ECOLOGIZATION OF THE ECONOMY, ENERGY SAVING AND ITS DIRECTIONS

3.1. Ecologization of the economy

The conditions of the Association Agreement Ukraine and the EU provide for the introduction of sustainable economic development and the mechanisms of "green" economy that meets the principles of the sustainable development strategy adopted at the UN Summit "Rio + 20". The ecologization of the economy means the purposeful process of its transformation, aimed at reducing the integral eco-destructive impact of production and consumption of goods and services on the unit of the aggregate social product [3, p.171]. The process of ecologization the economy has two dimensions: ecological modernization of the economy and creation of new "green sectors" of the economy. The detailed analysis of ecologization by sectors of the economy is given in Table 2 [7].

Table 2: Detailed analysis of ecologization by sectors of the economy

Sectors of economy	New «green» directions	Ecological modernization
Energetic	- small energetics; - wind power; - solar power; - bioenergy	- use of coal bed methane; - cleaning equipment in power plants; - use of secondary energy resources
Resource	- wind, solar, hydro and bio-energy	- extraction of shale gas; - use of local sources.
Food	- introduction of eco-labeling; - development of organic agriculture	- control over the cultivation, production, sale and consumption of genetically modified organisms
Social	- adaptation of the households and the population to climate change; - increasing energy efficiency of housing; - forming a system of sustainable consumption	- systemic measures for the prevention of emergencies of technogenic origin
Regional economy	- development of the "green" economy in the regions	- rehabilitation of radiation-polluted areas as a result of the Chernobyl accident; - water management; - recreation of forests and protected areas
Industrial	- "green" building, energy saving technologies and materials produced with minimized environmental damage; - development of green tourism; - introduction of "green" technologies	- energy saving in production; - «more clean production»; - joint implementation projects under the economic mechanism of the Kyoto Protocol
Transport	- development of "green" transport - trolleybuses, trams, electric cars, bicycles	- limitation of emissions of auto transport, air transport; - logistics
Financial	- formation of the carbon market; - green purchases; - "green" tariffs for electricity	- calculation of losses from emergency situations

Ecologization of technologies is the development and introduction into production processes that, with the maximum possible receiving of high-quality products to satisfy the specific needs of consumers, should ensure the preservation of ecological balance [2, p.20]. At the same time, the main conditions are: scientifically grounded extraction of natural resources does, that not lead to irreversible consequences of environmental changes, the maximum possible processing of initial natural raw materials, minimize waste and losses of all materials and energy with the possibility of adapting the substances that go into an environment. The policy of ecologization the economy is an instrument of modernization and attraction of new technologies that will create new jobs and reduce the negative impact on the environment. Implementation of the mechanisms of the "green economy" can become a tool for redistribution of capital from old low-tech and resource-intensive industries into new high-tech industries, new products of export to EU countries.

3.2. Energy saving and its directions

Energy Conservation (or a more accepted term in Ukraine “Energy Saving”) refers to a reduction in energy consumption by using less quantity energy services [11]. Energy savings are different from energy efficiency, which refers to the use of less energy for the same service. Though energy saving reduces energy service consumption, its result may be an increase in the quality of the environment, national security, and personal financial security. Energy conservation is at the top of a sustainable energy hierarchy. Implementation of energy-saving technologies in the economic activity of enterprises and households is one of the important steps in solving many environmental problems - climate change, atmospheric pollution, resource depletion and others. Energy saving is the efficient use of energy resources through the application of innovative solutions that can be technically implemented, economically justified, environmentally and socially acceptable, and do not change the habitual way of life. The main directions of energy-saving technologies can be subdivided into several categories: thermal energy saving in production, transport and consumption; saving of electric energy; saving water at intake, transportation and consumption; fuel savings in the production of electricity and heat; accounting of water, gas, heat and electricity; energy audit, energy surveys, creation of energy passports; renewable sources of heat and electric energy. Conditional, modern energy-saving technologies can be divided into several types depending on the fields of using: energy-saving technologies in production, transport, individual consumption, general consumption. The main directions and methods of energy saving:

1. Save electric energy (lighting, electric drive, electric heating and electric cookers, refrigeration units and conditioners, consumption of domestic and industrial devices, reduction of losses in the power grid).
2. Heat savings (reducing heat losses, improving the efficiency of heat supply systems).
3. Water saving (water intake, consumption in the home and at work, reducing losses and improving the efficiency of water supply systems).
4. Gas savings (consumption in the household and at work, reducing losses and improving the efficiency of gas supply systems).
5. Fuel saving (reduction of consumption in internal combustion engines, alternative types and hybrid systems, reduction of losses and increasing the production efficiency of electric and heat energy).

4. ASSESSMENT OF ENVIRONMENTAL SUSTAINABILITY UKRAINE

4.1. Environmental Performance Index

The assessment of the current state of the ecological component of Ukraine's economy represents the results of the international environmental ranking started by analysts Center for Environmental Policy and Law at Yale University and Columbia University and the World

Economic Forum in the 2000 year. Environmental Performance Index (EPI) is a method of quantitative assessment and comparative analysis of environmental policy indicators in the countries [12]. EPI ranked countries by effectiveness in several categories, which are combined into two groups: human health protection and ecosystem protection. The index is published every two years. The first place by the level of environmental efficiency in 2018 received Switzerland (EPI=87,42). The top ten also included leaders: France, Denmark, Malta, Sweden, United Kingdom, Luxembourg, Austria, Ireland, Finland [14]. Ukraine in the rating of environmental efficiency in 2018 significantly deteriorated its results compared to 2016 and dropped from 44 positions (EPI = 79.69) to 109 positions (EPI = 52.87) from 180 countries surveyed. The countries in the rating are distributed on the basis of criteria, united in 10 categories, the detailed analysis of which allows to identify the country's strengths and weaknesses in the field of environmental efficiency (Fig.2).

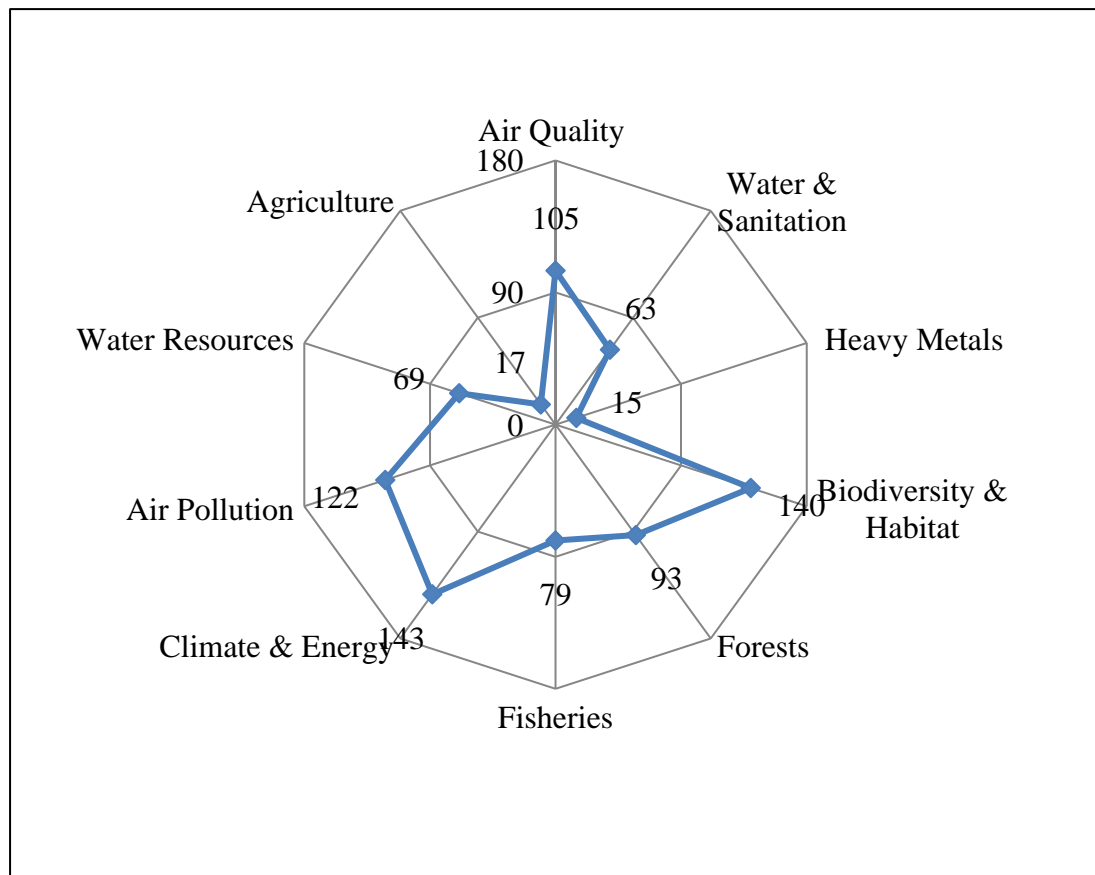

Figure 2: Positions of Ukraine in terms of criteria for assessing EPI
Source: created of author on base [14]

Thus, with 109 positions in EPI, Ukraine occupies 143 positions from 180 countries by criterion «Climate and Energy», that related N₂O Emissions Intensity (168 positions), Methane Emissions Intensity (141 positions) and Total CO₂ Emissions Intensity (134 positions); 140 positions by criterion «Biodiversity and Habitat», that related Biome Protection (Global) (148 positions), Biome Protection (National) (148 positions) and Species Protection Index (133 positions); 122 positions by criterion «Air Pollution», that related PM_{2.5} Exposure (133 positions) and PM_{2.5} Exceedance (129 positions) [14]. Minimization of the nature consumption indicator is based on the possibilities of reducing the volume of natural resources through the improvement of technologies, the introduction of low-waste and resource-saving technologies and production, the use of secondary resources. To ensure this process is possible under condition sustainable development as prerequisite transformational changes in Ukraine.

4.2. Energy Architecture Performance Index

The World Economic Forum published an annual study of the energy systems efficiency in the world – Global Energy Architecture Performance Index Report 2017 or Energy Architecture Performance Index [13]. The index is calculated on the basis of 18 indicators grouped in three directions, which give an assessment of how much energy systems of the studied countries contribute to their economic growth and development, environmental sustainability, energy security and access to energy sources. Rating in 2017 covered 127 countries, the first place as last year, took Switzerland. The top ten also includes Norway, Sweden, Denmark, France, Austria, Spain, Colombia, New Zealand and Uruguay. Last ranking occupied Yemen (126) and Bahrain (127). Ukraine this year took place 73 to 72 last year. Energy Architecture Performance Index of our country is 0.58 points as last year. Figure 3 shows Ukraine's positions in three directions, which are evaluated for EAPI.

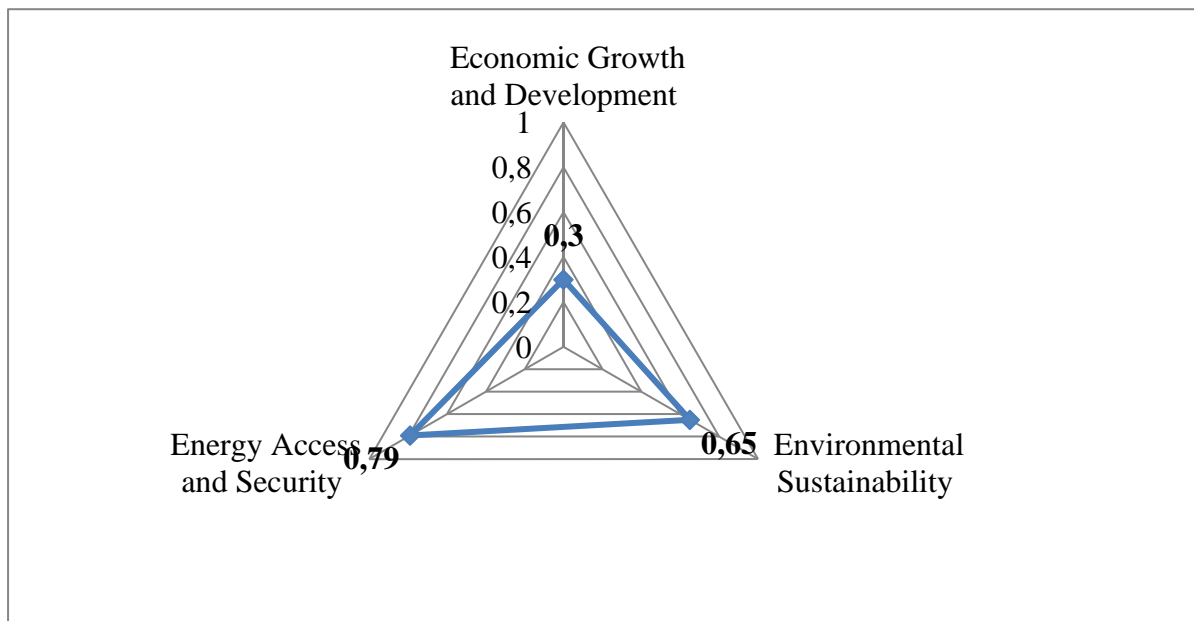

Figure 3. Positions of Ukraine in the Energy Architecture Performance Index (0→1 better) [13]

Ukraine has best places by criteria of Electrification rate (1 position) and Diversity of TPES (Herfindahl index) (25 positions). Experts note that every country has the potential to provide the population with safe, affordable and sustainable energy, regardless of the development level of its economies and geographical location. However, the development of power systems requires constant effort and cooperation between the state and private sectors in the long term.

4.3. Legislation and state program directions for energy saving in Ukraine

In September 2015, 193 world leaders adopted a new sustainable development program and concluded a new global climate change agreement. As a result, new Goals for Sustainable Development have emerged, that based on the eight Millennium Development Goals. The New Sustainable Development Goals (CSRs), which today all countries and Ukraine adhere, set development indicators and include 17 goals and 169 specific tasks. The list of CSRs was officially approved by the UN General Assembly at the end of September 2015. In CSRs by 2030, much emphasis is placed on ecologization of the economy [9]. So, Goal 7 "Affordable and clean energy" involves ensuring everyone's access to reasonable price, uninterrupted, sustainable and modern energy supply. Goal 8 "Decent work and economic growth" envisages an increase in the total efficiency of consumption and production of resources, and also

promoting to economic growth, taking as an example the experience of developed countries in order to counter environmental degradation. Goal 9 “Industry, Innovation and Infrastructure” involves modernizing the infrastructure and modifying the industry, ensuring their sustainable development, increasing the efficient use of resources and environmentally sound technologies and production processes. Goal 11 "Sustainable cities and communities" promotes integration, security, adaptability to changing conditions and urban sustainability. Goal 12 "Responsible consumption and production" substantiates the task of implementing the principles of sustainable consumption and production. According to the Strategy of the State Environmental Policy of Ukraine for the period up to 2020, sustainable development can be defined as the process of ecologization not only the economy, but also public life in general, the harmonization of productive forces through the introduction of bioeconomic principles of management, satisfaction of necessary social needs with conditions preservation and phased reproduction of the environmental integrity, ensuring a balance between the natural potential and the population requirements [10]. In 2017, the Government approved the Energy Strategy of Ukraine for the period up to 2035 "Security, Energy Efficiency, Competitiveness" aimed at ensuring energy security and sustainable development of the energy sector [6]. The State Target Economic Energy Efficiency Program aims at forming conditions for approaching the energy intensity of gross domestic product of Ukraine to the level of developed countries and the standards of the European Union, reducing the level of energy intensity of the gross domestic product during the Program by 20% compared to 2008 (3.3% annually), increase of efficiency of use of fuel and energy resources and strengthening of competitiveness of the national economy [1].

The main directions of the Program:

- introduction of the latest production and consumption technologies of energy resources;
- use of solar and geothermal energy;
- production and use of biofuels;
- development of wind energy, small hydropower and bioenergy;
- modernization of the gas transportation system, heat and water supply systems, heat power plants;
- implementation of measures to reduce consumption energy resources by institutions financed by the state budget;
- reducing environmental pollution;
- restructuring of enterprises with aims of reducing material and energy intensity of production, etc.

5. CONCLUSION

The study of energy efficiency policy of energy saving countries-leaders shows that it is based on three basic principles: energy saving incentives; coercion to energy saving; educational programs in the energy saving sphere. The energy saving potential in Ukraine consists of technical and structural components. The technical (technological) component can be realized by increasing the efficiency of production (extraction), transformation, transportation and consumption of energy resources and, accordingly, reducing the energy intensity of products and services through the introduction of the latest energy-efficient technologies and energy saving measures. The structural component implies a change in macroeconomic proportions in the economy in order to reduce energy consumption; reducing the proportion of energy-intensive sectors, industries and transport through the development of high-tech sectors and industries with low energy and material intensities. Also, need to pay attention to measures by an implementation of energy efficiency in the housing sector: energy audit and energy modernization of buildings, energy certification of buildings, modernization of heat supply systems, and others. Ensuring energy security and competitiveness is impossible only at the expense of energy saving measures.

Therefore, it is necessary to introduce advanced producing energy technologies from renewable sources in parallel. In addition to economic and environmental feasibility, an increase in energy efficiency is necessary for Ukraine to strengthen national energy security, as well as for joining the European and world energy markets.

LITERATURE:

1. Cabinet of Ministers of Ukraine. (2018). *Resolution "On Approval of the State Target Economic Program for Energy Efficiency and Development of the Energy Sector for Renewable Energy Sources and Alternative Fuels for 2010-2020"*. Retrieved May 3, 2018 from <http://zakon5.rada.gov.ua/laws/show/243-2010-%D0%BF/paran14#n14>
2. Grechanovskaya, I. (1997). *Economic and ecological regulation of business activities*. Odessa: AOZT IRENTT.
3. Melnik, L. (2001). *Ecological economics*: Sumy: University Book.
4. Ministry of Ecology and Natural Resources of Ukraine. (2017). *National Report on the State of Environment in Ukraine in 2015*. Retrieved May 12, 2018 from <https://menr.gov.ua/news/31768.html>.
5. Ministry of Ecology and Natural Resources of Ukraine. (2018). *Ukraine's Greenhouse gas inventory 1990-2016 Draft: Annual National Inventory Report for Submission under the United Nations Framework Convention on Climate Change and the Kyoto Protocol*. Retrieved May 12, 2018 from https://menr.gov.ua/files/docs/Zmina_klimaty/Ukraine_NIR_2018%20project.pdf
6. Ministry of Energy and Coal Industry. (2017). *Energy Strategy of Ukraine*. Retrieved May 3, 2018 from <http://mpe.kmu.gov.ua/minugol/doccatalog/document?id=245239554>
7. National Institute for Strategic Studies. (2017). *State policy of sustainable development on the principles of "green" economy*. Retrieved May 8, 2018 from <http://www.niss.gov.ua/articles/1237/>
8. The World Bank. (2018). *World Development Indicators*. Retrieved May 12, 2018 from <http://databank.worldbank.org/data/reports.aspx?source=2&series=EG.USE.COMM.GD.PP.KD&country=#>
9. United Nations Ukraine. (2017). *Sustainable Development Goals*. Retrieved May 1, 2018 from <http://www.un.org.ua/ua/tsili-rozvytku-tysiacholittia>
10. Verkhovna Rada of Ukraine (2011). *The Law of Ukraine "On the Basic Principles (Strategy) of the State Environmental Policy of Ukraine for the Period until 2020"*. Retrieved May 3, 2018 from <http://zakon5.rada.gov.ua/laws/show/2818-17>
11. Wikipedia. (2018). *Energy saving*. Retrieved May 1, 2018 from <https://uk.wikipedia.org/wiki/Енергозбереження>
12. Wikipedia. (2018). *Environmental Performance Index*. Retrieved May 1, 2018 from https://uk.wikipedia.org/wiki/Індекс_екологічної_ефективності
13. World Economic Forum. (2017). *Global Energy Architecture Performance Index Report 2017*. Retrieved May 3, 2018 from <https://www.weforum.org/reports/global-energy-architecture-performance-index-report-2017>
14. Yale Center for Environmental Law & Policy (2018). *2018 Environmental Performance Index*. Retrieved May 1, 2018 from <https://epi.envirocenter.yale.edu/>

GROSS AND NET ASSETS IN THE EUROPEAN UNION COMMUNITY IN 2006 - 2016 (CASE STUDIES)

Urszula Banaszczak-Soroka

The Faculty of Law, Administration and Economics, University of Wrocław, Poland
urszula.banaszczak-soroka@uwr.edu.pl

ABSTRACT

In economic theory, a household is one of the basic business entities next to the enterprise and the state. Gross (non-financial and financial) assets as well as net assets (gross assets reduced by the size of debt) collected by the household have been studied by economists in terms of their impact on the growth of the society's wealth and economic development. The presented article includes the study of the countries belonging to the so-called "old" and "new" (ten countries that joined the EU after 2004) European Union, taking into account such values as: gross wealth, indebtedness and net assets per capita (per adult) as well as the dispersion of these values. The main source of output data was the Global Wealth Databook report prepared by the Credit Suisse Bank A.G. The gross per-capita assets in the audited period (2006-2016) increased in all EU countries by 108.9%, debt by 12.50%, and net assets 8.72%. Analysing the group of "new" EU countries that we were interested in, they recorded an increase in gross assets by 23.60%, debt by 38.00%, and net assets by 7.00%; and in the case of other EU countries adequately (gross assets – 7,60%, debt by 10.00%, net assets by 7.00%). Although the countries that joined the EU after 2004 recorded a higher increase in gross and net assets per adult in relation to other countries, their position did not improve and they remained in the least prosperous zone during the entire period considered. In the analysed period, in the examined group of 27 countries, the discussed per capita figures of countries from the first quartile (only the countries from the "new" EU) exceeded the median by 10-15%, while the third quartile countries (only the "old" EU countries) exceeded the median by several times. This indicates huge disproportions in the wealth of citizens of the "old" and "new" EU countries.

Keywords: *gross asset, GDP, household, net assets, UE*

1. INTRODUCTION

In economic theory, a household is one of the basic business entities³ next to the enterprise and the state. This micro-entity is an active participant in economic processes, functioning both in the sphere of consumption and for consumption (Zalega, 2012, p.81-87 ; Bywalec, 2017, pp. 15-18; Milc-Czeraniak, 2009, p 110- 119) In the context of this article, the household will be perceived through the prism of natural persons aged 20 and over. This approach to the examination of wealth (assets) and indebtedness for one adult was applied in the Global Wealth Databook⁴ (hereinafter GWD), a report whose data regarding the studied phenomenon will be used in this publication. In the opinion of the authors of the report, this approach is supported by the fact that adults are both property and income disposers. It was considered that even if people under 20 earn a living, the money is usually passed on to adult household members (GWD 2017, p.5).

³ Increasingly, this micro-entity is treated as a central element in the structure of the economy in both economic literature, for example (Bywalec, 2012) as well as in EU documents, e.g. Commission Communication 2010/2020 final version: EUROPE 2020 A strategy for smart, sustainable and inclusive growth EUR-lex. 52010DC2020 http://ec.europa.eu/eu2020/pdf/1_PL_ACT_part1_v1.pdf if Regulation (EU) No 254/2014 of the European Parliament and of the Council of February 26, 2014 on the multiannual consumer program for 2014 - 2020 and repealing Decision No. 1926/2006/WE (Official Journal of EU, L 84/42 of March 20, 2014).

⁴This report has been prepared for several years by Credit Suisse Bank A.G file:///C:/Users/ubs/Downloads/global-wealth-databook.pdf (access April 10, 2018).

The aim of the study is to analyse the size of gross assets, indebtedness and net assets of adult natural persons of the “new” EU countries (11 countries that joined the EU after 2004⁵) in relation to the “old” EU countries (16 countries⁶) both in terms of the absolute size of the indicated attributes and the rate of their growth in the period 2006–2016⁷. Taking into account the availability of data as of the end of each calendar year, the analysis is of a microeconomic. The issue of financial assets of natural persons is analysed from various points of view. This topic appears in many books and scientific articles. We can mention several authors from Poland: eg Korenik (2003), Milc-Czerniak (2016) or Bywalec (2017). A wider approach: net gross wealth and household debt (natural persons) are met with increasing interest not only by economists but also politicians or social activists, e.g. Pikett (2014) or in research carried out for several years by the European Central Bank - Household Finance and Consumption Survey (ECB JEL2017), in which the National Bank of Poland participates, preparing and publishing the second consecutive report entitled Households' wealth in Poland (NBP 2017). Hypotheses: between adult natural persons from countries that joined the EU after 2004 and others, there are significant inequalities in property (gross, net) as well as in the value of debt in terms of value. The growth rate of assets and indebtedness of adults from CEE countries in the analysed decade is higher than the increase in the surveyed values of adults from other countries. The respondents are subject to strong cyclical influence in the entire surveyed population of EU countries. In the preparation of the article, the following research methods were used: analysis of economic literature and quantitative statistical analysis.

2. BASIC CONCEPTS

One of the main factors determining the basic financial behaviour of a household (or of an adult) is the level of disposable income (the sum of monetary and non-monetary⁸ income of a household will be reduced by advances on taxes as well as social and health insurance premiums). The generated financial surplus (disposable income reduced by consumption expenditure), by the decision of households, may be directed to the financial market or the non-financial market. There are numerous objective reasons (independent of the household) and subjective reasons on the distribution of disposable income – apart from income. In the economic literature, the subjective group includes, among others: prudence, foresight, calculation, independence, entrepreneurship, and even the motive of avarice, phase of life, down payment, prepayments and others. (Keynes, 2003, p.75; Owsiak, 2016, p. 222; Milic-Czerniak, 2016, pp. 108-109) Objective ones include, among others: changes in fiscal policy, interest rates, changes in stock markets, inflation, political changes, etc. In temporal terms, financial surpluses (savings) build wealth (assets) of the household, consisting of non-financial (material) and/or financial assets. Wealth only covers those assets and liabilities that are private property of the household and are subject to market valuation. The material side of the property is represented, among others, by: real estate (including the main residence), vehicles (e.g. cars, boats, airplanes, motorcycles), valuables and other valuable items or property components resulting from running a business activity on the basis of self-employment.

⁵ The Czech Republic, Estonia, Latvia, Lithuania, Slovakia, Slovenia, Hungary and Poland joined the EU in 2004, followed by Bulgaria and Romania in 2007 and Croatia in 2013 respectively.

⁶ Great Britain was excluded from the study due to the withdrawal from the EU.

⁷ It should be emphasized that the correctness of the argument should take into account a number of other aspects of the discussed problem, including such issues as: disposable income, consumption, structure of financial and non-financial assets, structure of income and liability debt to GDP, distribution of assets, price changes, interest rates, loan costs, dollar exchange rate and many more. However, taking into account the volume of the publication, the focus was on three variables: gross assets, debt and net assets, in order to meet the objective indicated in the article at the general level. The author's plans include exploring the presented issue in subsequent publications, which will take into account further aspects of the studied problem.

⁸ The basic components of household income are listed e.g. in Regulation No. 549/2013 of the European Parliament and of the (EU) Council of May 21, 2013 on the European System of National and Regional Accounts ESA 2010 in the part: Institutional sectors – households S 14 (Official Journal, L 174/1 z 26.6.2013).

On the other hand, the structure of financial assets includes, among others, such items as: deposits, investments in bond funds, shares listed on stock exchanges, funds entrusted to management, derivatives, voluntary pension funds, life insurance or financial claims e.g. due to loans, promissory notes, etc.⁹ In the initial phase of their creation, on the one hand gross assets stem from savings, on the other hand from income from previous savings and redistribution of assets accumulated by previous generations. Wealth may also be depleted due to a decrease in the value of fixed assets, taxes paid, unrest in financial or political markets, and the fact that the maintenance of tangible assets is costly (due to insurance, maintenance, repairs, management, etc.). Growth of wealth in the long term can be supported by loans, especially mortgage loans. In the short term, the loan has to be repaid, which reduces the savings. In contrast, the use of loans for the purpose of expanding consumption (unpaid debt on credit cards, credit lines, arrears with repayment or loans) reduces irretrievably the savings of a natural person and even generates additional costs. Any liability arising from the use of an external payment must be repaid in a shorter or longer period. Therefore, from the point of view of the wealth of households, an important issue is not only the size of gross assets but, above all, the net assets (gross assets lessened by financial liabilities). This issue is important because the assets possessed not only testify to the wealth and financial stability of the society but, in particular in the case of financial assets, they are a source of capital for other economic entities. This capital (financial assets), as stated by Owsiak (2015, p. 222), Dorosz (2016 p. 77-80) “enables the economy to make physical investments, which in turn provide the basis for economic growth and general development of society.” The presented statistical data on the issues of gross assets, debt and net value are presented in nominal terms, without taking into account the inflation rate. Such an approach may slightly falsify the real states, but it allows to capture some general tendencies. The observation of the economic environment proves, in general terms, that the increase in prices affects the increase in the value of numerous material and financial assets: an increase in prices of shares, gold, real estate, works of art, etc. A decrease in prices has the opposite effect. Reducing the interest rate encourages taking loans, while the increase of the interest rate discourages from it. The course of business cycles has a major impact both on the change in the prices of tangible and financial assets, as well as on the behaviour of people with assets. In each country, business cycles are usually different, although crises on a global, regional or even local scale may have very similar effects in a narrower or wider spatial layout. An example is the global crisis of 2007 or, locally, the Greek, Spanish, Portuguese or Italian crisis, which had an impact, on a smaller or larger scale, on other EU countries for many years. Apart from business cycles and other factors mentioned above, the value of the analysed features is also influenced by currency exchange rates. Gross assets per one adult in all EU countries were valued in 2006 at USD 4.044.689 and ten years later at USD 3.711.332 which gives slightly more than 8,98% increase. The indebtedness amounted to USD 659.517 in 2006 and in 2016 to USD 742.089 (increase by 12.50%), while the net assets in 2016 were valued at USD 3.314.368 and ten years earlier at USD 3.064.011 (increase by 8,20%). Between the first and the last of the researched years, there are both significant increases and significant decreases in the analysed volumes. Good economic situation in the half of the first decade of 21st century and the beginning of the next decade supported a strong increase in gross and net assets, but also indebtedness (e.g. 2006-2007 or 2012-2013), while deterioration (caused by numerous crises) resulted in a significant reduction in the value of assets and giving up on loans (2007-2008 or 2013-2014)¹⁰. Analysing the discussed values in the division on CEE countries and other EU states, the following should be noted: first of all,

⁹ After: Central Bank Report of the European Household Finance and Consumption Network (HFCN), 2017, p.63 https://www.ecb.europa.eu/home/pdf/research/hfcn/HFCS_Statistical_Tables_Wave2.pdf?58cf15114aab934bcd06995c4e91505b (access April 15, 2018).

¹⁰ The economic situation affected not only the size of the property, but its structure as well, e.g. financial assets Banaszczak-Soroka (2018, p. 141-163)

that the CEE countries were characterised by a faster growth in gross assets in the studied decade (CEE countries 23,6 % others – 7,5%), indebtedness (respectively 38,00% and 10,00%) and net assets (respectively 18,90 % and 7,20 %) compared to other EU countries, and secondly, that both groups were also, to a significant extent, subject to the same cyclical inflows. If we take a gross assets, debt or net assets from 2016 to 2007 (the beginning of the crisis), the picture is not very satisfying. Gross assets in the CEE countries have decreased by 5,1% net by 7.2% and debt by 4.2%. Adequate in other EU countries: gross assets 7,8% net wealth at 7.5% and indebtedness by 9.3%. Conclusion - until 2016, adults in total from both the CEE and other EU countries have not recovered from the crisis when gross and net assets were in crisis. On the other hand, greater aversion to drawing loans by adults from the countries of the "old" EU and the "new" EU was observed (Fig.1 end 2).

3. GROSS ASSETS OF ADULT NATURAL PERSONS IN EU COUNTRIES

By ranking EU countries according to gross assets per capita (from the lowest value to the highest), there is an evident division into the countries of Central and Eastern Europe (CEE) that joined the EU after 2004 and others that are much longer in the structures of the organisation. Twenty-five percent of the population (seven countries) designated by the first quartile (countries with gross value per capita at most equal to the first quartile we will call first quartile countries) recorded the assets of adults from the following countries in alphabetical order: Bulgaria, Croatia, Lithuania, Latvia, Poland, Romania and the four CEE countries: the Czech Republic, Estonia, Hungary, and Slovenia were all located above the first quartile. The first quartile determined gross assets of adults, inhabitants of Slovakia and in two years, adults living in Poland. The gross value of real estate belonging to adults in Slovakia was in the range of USD 25.189 in 2006 to USD 33.417 in 2012, whereas adults in Poland range from USD 31864 in 2010 to USD 37.324 in 2013. In the group of countries included in the first quartile, there was a slight rotation of positions within the group. The reduction of gross assets per adult person or its increase, in different years of the examined period, resulted in shifting particular countries by one place up or down the table. In the years 2006-2016, the countries above the first quartile were in the same configuration: Hungary, Estonia, the Czech Republic and Slovenia. The least wealthy adults in 2006-2010 lived in Bulgaria, and in the following years in Romania. The lower limit of gross assets per one adult in the CEE countries was recorded in Bulgaria in 2006 at 14.127, and the upper limit was set by the adults of Slovenia – 84.985 in 2007. The characteristic feature of gross assets per adult of the first quartile countries is the relatively small variation in the size of gross assets (short line on the box chart).

Figure following on the next page

Figure 1: Gross assets, debt end net assets per adult in the CEE and in other countries EU (2006 -2016 USD)

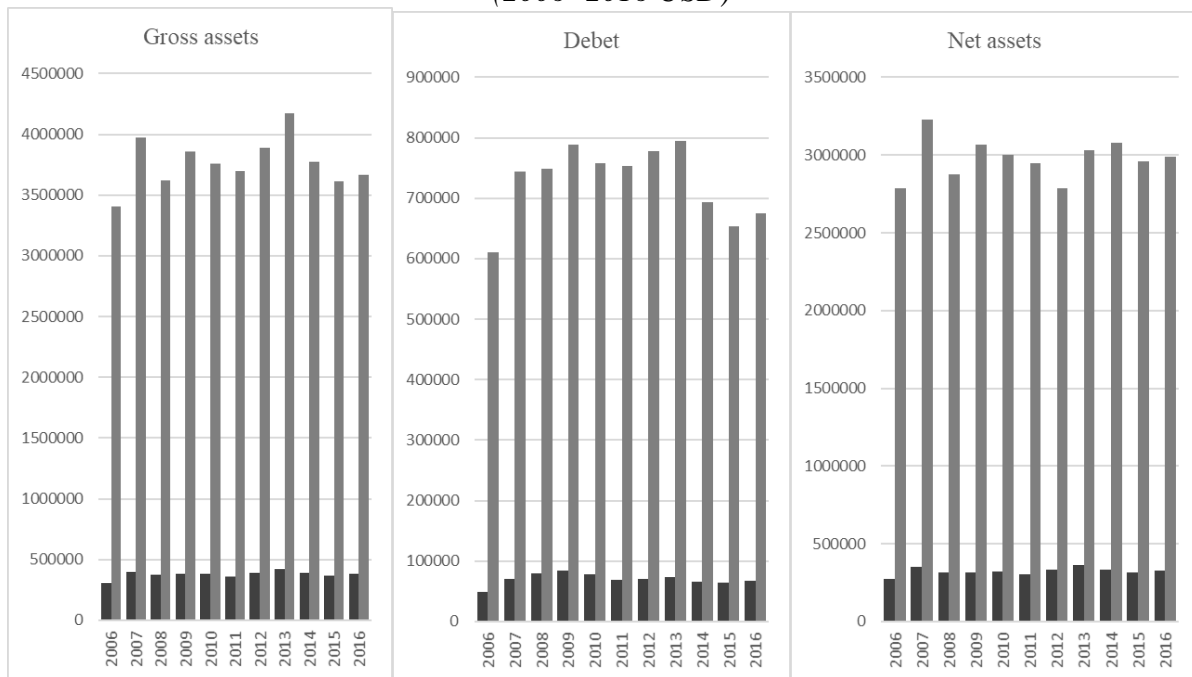

■ other countries EU ■ CEE countries

Source: own elaboration based on CDB 2017, Table 2-4, pp.55-98

Figure 2: The box chart - gross assets , debt and net assets per adult in 2006-2016 in EU countries.

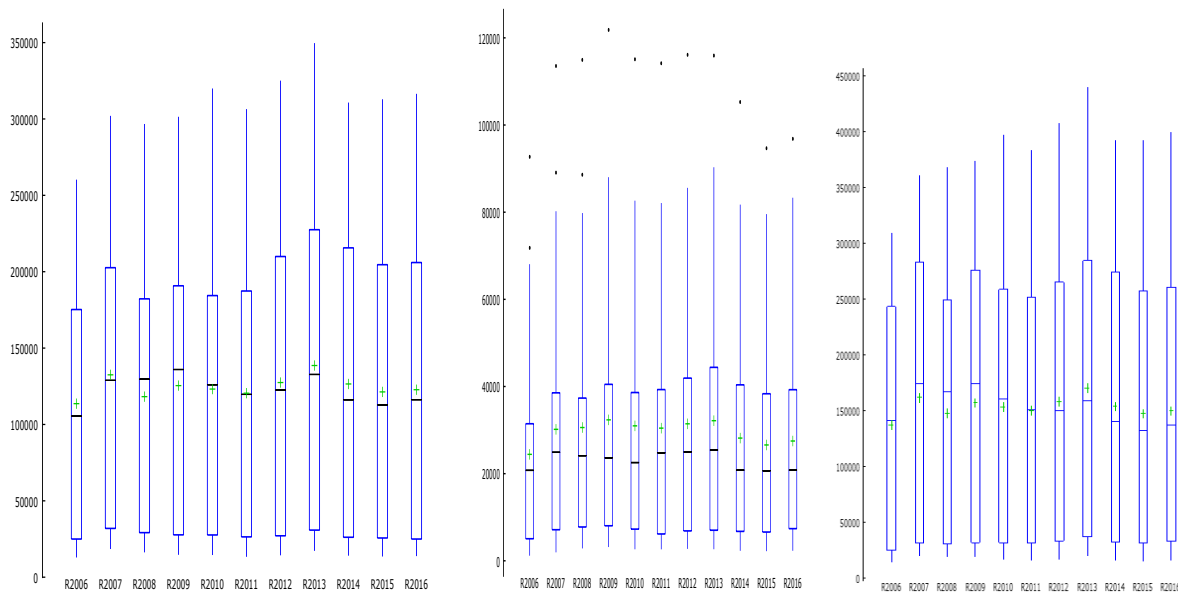

+ arithmetic average - median

Source: own elaboration based on CDB 2017, Table 2-4, pp.55-98

In the decade under review, there has been noticed a disturbing phenomenon of the progressive stratification of gross assets per adult between Bulgaria / Romania and Slovakia. In 2006, it was about 11.00 thousand dollars and in 2013 - just over 175,000 dollars (an increase of around

64%). If, however, we take into account the entire population of CEE countries, these differences are greater – from USD 43.000 in 2016 to a maximum of USD 58.900 in 2009 (relation Romania – Slovenia). Throughout the period considered, adults living in the “new” EU countries did not exceed the gross assets of the least well-off citizens of the “old” EU – the Portuguese. Slovenians, the richest among the adults of CEE, was behind the Portuguese population by around USD 20.000. Twenty-five percent of the surveyed population (seven countries), designated by the third quartile (countries with assets equal and higher to the third quartile we will call the third quartile countries) have the highest gross assets per adult in the entire EU. The lower limit of the examined feature (third quartile) was determined by the following countries: the Netherlands in 2006-2008; Austria in 2009, 2011, 2013 and 2016, and Italy in 2014-2015. Gross assets of their citizens ranged from USD 175.000 in 2006 (the Netherlands) to a maximum of USD 209.000 in 2012 (Austria). On the other hand, the upper limit of the third quartile is marked by Luxembourg’s gross assets, which remain the highest during the period considered. Between the lower and upper limits of the surveyed variable, the persons with the highest gross assets per adult lived, in various configurations, in the following countries: Belgium, Denmark, Ireland, France and Sweden. The gross amount of assets at Luxembourg’s disposal in 2006 was USD 260.000, to reach the highest level in 2013 at USD 349.700. The characteristic feature of gross assets per capita in the countries of the third quartile was the significant spread of the examined variable (long line on the box chart). These differences were between USD 90.000 (in 2014) and USD 135.000 (in 2010). While assessing the spread between the adults from Luxemburg and the second wealthiest country in the order (most often Belgium or France), it should be noted that in 2006 the difference was only USD 4.800. In subsequent years, the stratification of gross property of adults from these countries grew rapidly, arriving in 2012-2016 at over USD 50.000. The analysis of the above-mentioned values (gross property per adult) leads to the conclusion that between the inhabitants of Luxembourg (the wealthiest) and Romania (the poorest in the entire population), a huge property gulf is drawn. Residents of Romania have only about 5% of Luxemburg’s gross assets, and the inhabitants of Slovenia (the wealthiest among the least well-off countries) are within one-fifth of those. Referring gross property per adult of selected countries to the median (distribution of assets shows right-sided asymmetry, which means that in the surveyed population there is a country, due to which the average is perceived as higher than it actually is in the population – and it is Luxembourg), it is noticeable that Romania’s gross assets were usually seven to eight times less than the median, while Luxembourg’s gross assets were two to 2.7 times the median value. The median value was determined successively by Cyprus in the years 2006-2007, Spain in 2008-2013, again Cyprus in 2014, then Malta in 2015-2016, and these were values in the range of USD 105.000 in 2006 (Cyprus) to USD 135.000 in 2009 (Spain). Only when we compare the gross assets of adults of all CEE countries to the median, we receive a result similar to the richest inhabitants – the Luxembourgers. The size of gross assets per person in all CEE countries was greater than the median within 2.3 times in 2009 to 2.9 times in 2014. This data confirms the thesis about low gross assets of adults in the CEE countries, when in relation to the median, “new” EU countries together achieve a level of property close to one richest adult Luxembourger. (GWD 2017, Table 1-4, pp.55-98; Fig 2)

4. INDEBTEDNESS OF ADULT NATURAL PERSONS IN EU COUNTRIES

By juxtaposing, similarly to gross assets per adult, the debt in EU countries, we receive a similar basic arrangement in the table. Adults living in the CEE countries occupy positions in the lower debt levels – the least indebted, whereas adults from the “old” EU in the upper states – the most indebted. Twenty-five percent of the population surveyed – seven countries designated by the first quartile – shows the indebtedness of adults from the following countries listed alphabetically: from Bulgaria, Croatia, the Czech Republic, Hungary, Lithuania, Latvia,

Poland, Romania, and Slovakia. However, above the first quartile, there are people living in the following countries, in alphabetical order: Croatia, the Czech Republic, Estonia, Latvia, Slovakia and Slovenia. It is worth noting that the variability of the indebtedness of adults from the “new” EU countries (increase or decrease in debt) in each year built their variable positioning not only within the first quartile but within all eleven CEE countries. On the list of CEE countries, only two occupy the same places in the entire analysed period: Slovenia is the tenth in terms of indebtedness of adults and Estonia is eleventh. These are two countries where adults are the most indebted in the population of the CEE countries. The first quartile (the seventh country) determined the indebtedness of the adult inhabitants of Slovakia in 2006, Latvia in 2009 and 2011, and the indebtedness of the citizens of Croatia in the remaining years. The value of indebtedness of adults from first quartile countries was in the range from USD 5.000 in 2011 (Slovakia) to USD 8.000 in 2009 (Latvia). The least indebted adults came interchangeably from Romania or Bulgaria. The lowest indebtedness in these countries was recorded in 2006 – USD 1.200 (in Bulgaria), the highest in 2009 – USD 3.200 (in Romania). On the other hand, the debt of adults from Estonia was set in the range between USD 9.000 (2006) and USD 14.000 (in 2008 and 2009). A characteristic feature of the indebtedness of the countries of the first quartile is its relatively small diversity (short line on the box chart). The smallest difference occurred in 2011 – USD 3.500, the largest in 2007 – USD 5.200. Considering all CEE countries, the stratification is twice as large, from USD 7.900 in 2011 to USD 10.200 in 2010. It is interesting to note the persisting difference in debt between the most indebted and the least indebted in the group of CEE countries on a stable level since 2011, which is about USD 8.500. There also occurs a similar phenomenon here as in the case of gross wealth in property. The indebtedness of adult citizens of the “new” EU countries did not exceed the indebtedness of the least indebted adults in the “old” EU – for Malta in 2006-2011 and for Greece in 2012-2016. However, the distance between Estonians and the least indebted people from the “new” EU was not as significant as in the case of gross assets (about USD 20.000), it stayed in the range between USD 4.500 in 2016 and nearly USD 9.700. Twenty-five percent of the surveyed population (seven countries), designated by the third quartile, is the most indebted. The lower limit of the examined feature (third quartile) was determined by two countries – in the years 2006-2012 by Spain, and then Finland. The indebtedness of the inhabitants of the countries designating the third quartile remained in the range of USD 31.000 in 2006 to USD 44.300 in 2013. By contrast, the maximum was the debt per one adult in Denmark throughout the period considered. The lowest indebtedness of adult Danes was recorded in 2006 – USD 92.000, the highest – 121.000 in 2009. As in the case of CEE countries, there were observed numerous movements of the “new” EU countries up or down the list. The characteristic feature of gross assets per person in the third quartile countries was the relatively high spread of the examined variable (long line on the box chart). These numbers amounted to as much as USD 75.000 in 2007. The debt of the Danes had an impact on such significant spans. When assessing the scale of indebtedness of adult residents of Denmark in relation to the next country on the list of the most indebted adult residents, Ireland (in 2006-2008) and then Luxembourg (2010-2016), there is a significant dissonance of the examined variable. Differences in debt amounted to as much as USD 30.000. In recent years, this disproportion was reduced, mainly due to the decreasing debt of the Danes. In 2016, the difference was about USD 13.000. The total debt of all adults from the CEE countries was the lowest in 2006 – USD 48.8000, and the highest in 2009 – USD 83.800. If we refer these amounts to the Danish debt in the same years, the share of CEE countries was 53% in 2006 and 69.0% in 2009, respectively. This data confirms the thesis about low gross debt of adults in the CEE countries, since the “new” EU countries together contribute to half of the debt of people from just one country – Denmark. Referring the indebtedness of the selected countries to the median (the distribution of assets shows right-sided asymmetry, which means that there is a state in the study population, due to which the

average is perceived as higher than it actually is in the population, in this case Denmark), it is possible to notice that the debt from the minimum position (alternately Bulgaria and Romania) was even 22 times smaller than the median (in 2007), only to stabilise at the level of about nine times smaller in the following years, with the median which, throughout the researched period, fluctuated between 20.000 and 25.000. In the following years, the median was determined by the indebtedness of an Italian adult (2006-2013) and further on by the Portuguese, the Maltese and the Finns. On the other hand, the debt of adult Estonian residents accounted for approximately 50% of the median. The Danes' debt was as much as five times higher than the median. (GWD 2017 Table 1-4, pp.55-98; Fig 2)

5. NET WEALHT OF ADULT NATURAL PERSONS IN EU COUNTRIES

Assuming a similar formula as in the case of the two identifiers discussed above, i.e. gross assets and debt for an adult person in EU countries, the same basic location was noted for them. In the lower part, for countries with the lowest net assets per one adult, there are located all the countries of the “new” EU. The other group is populated by the countries of the “old” EU. In the twenty-five percent of the population (seven countries) designated by the first quartile (countries with a net worth of assets per adult equal to the first quartile we will call the first quartile countries) there are, alphabetically, the following countries: Bulgaria, Croatia, Lithuania, Latvia, Poland, Romania; and above the first quartile, there are, in alphabetical order: the Czech Republic, Estonia, Hungary and Slovenia. The first quartile in 2006-2010 was determined by the net assets of adults, inhabitants of Croatia; in 2011 - 2015 – the inhabitants of Poland and in the rest (2016), the residents of Slovakia. The value of net assets of adults who designated the first quartile fluctuated around 25.000 USD. In the group of countries included in the first quartile, there was a rotation of positions within the group in each year. The reduction of net assets per one adult or its increase, in different years of the examined period, caused shifting individual countries up or down the list, even by a few positions, e.g. Poland, Croatia. Poland has moved one place up and Croatia even four, while Slovakia has moved two places down. Adults from two countries, the Czech Republic, Estonia, Hungary and Slovenia, kept the same position above the first quartile throughout the entire period. The lower limit of net assets of adults per one person in the CEE countries was recorded in Bulgaria at USD 12.015 per person, and the upper limit was set by the Slovenians in 2007 at USD 75.914. The characteristic feature of nett assets per adult of the first quartile countries is the relatively small variation in the size of gross assets (short line on the box chart). It oscillated around USD 12.000 in each year of the period considere. If, however, we take into account the entire population of CEE countries, these differences are greater – from USD 43.000 in 2016 to a maximum of USD 58.900 in 2009 (relation Romania – Slovenia). Throughout the period considered, adults living in the “new” EU countries did not exceed the net assets of the least well-off citizens of the “old” EU – the Portuguese. Slovenians, the richest among the adults of CEE, was behind the Portuguese population by around USD 20.000. Twenty-five percent of the surveyed population (seven countries), designated by the third quartile (countries with assets equal and higher to the third quartile we will call the third quartile countries) have the highest net assets per adult in the entire EU. The lower limit of the examined feature (third quartile) was determined by the following countries: the Netherlands in 2006-2008; Austria in 2009, 2011, 2013 and 2016, and Italy in 2014-2015. Net assets of their citizens ranged from USD 175.000 in 2006 (the Netherlands) to a maximum of USD 209.000 in 2012 (Austria). On the other hand, the upper limit of the third quartile is marked by Luxembourg's net assets, which remain the highest during the period considered. Between the lower and upper limits of the surveyed variable, the persons with the highest net assets per adult lived, in various configurations, in the following countries: Belgium, Denmark, Ireland, France and Sweden. The gross amount of assets at Luxembourg's disposal in 2006 was USD 260.000, to reach the highest level in 2013 at USD

349.700. The characteristic feature of net assets per capita in the countries of the third quartile was the significant spread of the examined variable (long line on the box chart). These differences were between USD 90.000 (in 2014) and USD 135.000 (in 2010). While assessing the spread between the adults from Luxemburg and the second wealthiest country in the order (most often Belgium or France), it should be noted that in 2006 the difference was only USD 4.800. In subsequent years, the stratification of gross property of adults from these countries grew rapidly, arriving in 2012-2016 at over USD 50.000. The analysis of the above-mentioned values (gross property per adult) leads to the conclusion that between the inhabitants of Luxembourg (the wealthiest) and Romania (the poorest in the entire population), a huge property gulf is drawn. Residents of Romania have only about 5% of Luxemburg's net assets, and the inhabitants of Slovenia (the wealthiest among the least well-off countries) are within one-fifth of those. Referring gross property per adult of selected countries to the median (distribution of assets shows right-sided asymmetry, which means that in the surveyed population there is a country, due to which the average is perceived as higher than it actually is in the population – and it is Luxembourg), it is noticeable that Romania's gross assets were usually seven to eight times less than the median, while Luxembourg's gross assets were two to 2.7 times the median value. The median value was determined successively by Cyprus in the years 2006-2007, Spain in 2008-2013, again Cyprus in 2014, then Malta in 2015-2016, and these were values in the range of USD 105.000 in 2006 (Cyprus) to USD 135.000 in 2009 (Spain). Only when we compare the net assets of adults of all CEE countries to the median, we receive a result similar to the richest inhabitants – the Luxembourgers. The size of net assets per person in all CEE countries was greater than the median within 2.3 times in 2009 to 2.9 times in 2014. This data confirms the thesis about low gross assets of adults in the CEE countries, when in relation to the median, “new” EU countries together achieve a level of property close to one richest adult Luxembourger. (GWD 2017 , Table 1-4, pp.55-98; Fig 2)

6. CONCLUSION

The analysis of data contained in the Credit Suisse report, divided by the author into two groups – the “old” EU countries (16 countries) and the “new” EU countries (11 countries), allows to articulate several basic conclusions. CEE countries were characterised by a slightly higher growth rate of both gross assets in relation to other countries (CEE – 123%, others – 107.50%) as well as net ones (respectively 118% and 107%). In comparison to other countries, adults from CEE are more and more willing to use external sources (respectively 138% and 110%), which is probably associated with the desire to increase consumption and to own a household. This increase in debt is perceived as lower due to the amount of net assets in the CEE countries compared to other countries. The examined values in the entire analysed period were subject to cyclical changes, which were caused mainly by crises. Their effects affected entire economies and, therefore, households, thus lowering the value of assets and discouraging indebtedness. Overcoming the crisis results in an increase in assets and the willingness to be indebted. In the entire analysed period, the population of CEE countries, taking into account the examined values per adult, was in the group of countries situated from the first to the eleventh place in the table arranged from the lowest gross and net assets and the lowest debt. None of the CEE countries in the entire decade has changed its position in relation to other EU countries, while numerous upward or downward movements within the group have been observed. The lowest gross assets belonged to adults residing in Bulgaria in 2006 – 14.127, the highest belonged to the Luxembourgers – USD 439.997. A similar disparity exists in net assets – the lower limit was determined by Bulgarian assets – USD 12.915 in 2006 and the upper one by the Luxembourgers – USD 349.670. The smallest indebtedness concerned Slovaks in 2011 – USD 1.200, the largest belonged to Danes – USD 121.000.

Adults from all CEE countries do not have such allowances as one adult resident in Luxembourg, taking into account gross and net assets. Between the inhabitants of countries located at both ends of the spectrum, there is a significant wealth gap

LITERATURE:

1. Banaszczak-Soroka, U. (2018). *Wielkość i struktura oszczędności gospodarstw domowych krajów Unii Europejskiej w kontekście planu inwestycyjnego dla Europy. Wybrane aspekty*. In E. Pancer-Cybulska, K. Biegun, *Czym żyje Unia Europejska? Wybór zagadnień* (p.135-166). Wrocław: Uniwersytet Ekonomiczny
2. Bywalec, C. (2012). *Ekonomia i finanse gospodarstw domowych*. Warszawa: PWN
3. Bywalec, C. (2017). *Gospodarstwo domowe. Ekonomia. Finanse*. Kraków: Wydawnictwo Uniwersytetu Ekonomicznego w Krakowie.
4. *Central Bank Report of the European Household Finance and Consumption Network* (2017) Retrieved 15.05.2018 from https://www.ecb.europa.eu/home/pdf/research/hfcn/HFCS_Statistical_Tables_Wave2.pdf?58cf15114aab934bcd06995c4e91505b
5. Milic – Czerniak, R. (2016) *Oszczędzanie oraz inwestowanie w gospodarstwach domowych*. In R. Milic- Czerniak, *Finanse osobiste. Kompetencje. Narzedzia. Instytucje* (p. 110- 119). Warszawa:Difin
6. Dorosz, A. (2016) *Majątek polskich gospodarstw domowych na tle innych krajów Europy Centralnej i Wschodnie*. Retrieved 15.04.2018 from <http://www.i.vistula.edu.pl/media/docs/CA719I7z9SWG2f1YDnErQ3LDP.pdf>.
7. *Europe 2020. A strategy for smart, sustainable and inclusive growth. Communication from the Commission* COM(2010) 2020 final 52010DC2020
8. *Global Wealth Databook 2016. (2017) Credit Suisse Research and the world's foremost experts*. Nowember 2017. Retrieved 15.04.2018 from <https://www.businessimmo.com/system/datas/92488/original/global-wealth-databook-2016.pdf>
9. Keynes, J.M. (2003). *Ogólna teoria zatrudnienia procentu i pieniądza*. Warszawa: PWN.
10. Korenik, D. (2003). *Oszczędzanie indywidualne w Polsce. Produkty różnych pośredników i ich atrakcyjność*. Wrocław: Wydawnictwo Akademii Ekonomicznej we Wrocławiu
11. Owsiak, S. (2016). *Finanse*. Warszawa: PWE.
12. Piketty, T. (2014), *Capital in the Twenty First Century*. London: The Belknap Press of Harvard University
13. *The Household Finance and Consumption Survey Wave 2 Statistical tables* (2017.)Frankfurt: European Central Bank, Eurosystem. Retrieved 25.04.2018 from https://www.ecb.europa.eu/home/pdf/research/hfcn/HFCS_Statistical_Tables_Wave2.pdf?58cf15114aab934bcd06995c4e91505b
14. Zalega, T. (2012). *Konsumpcja, Determinany –Teorie- Modele*. Warszawa: PWE.
15. *Zasobność gospodarstw domowych w Polsce Raport z badania 2016 r.* (2017) Warszawa: NBP. Retrieved 10.04.2018 from https://www.nbp.pl/aktualnosci/wiadomosci_2018/Raport_BZGD_2016.pdf

SOURCES OF ECONOMIC GROWTH IN THE AFRICAN, CARIBBEAN AND PACIFIC COUNTRIES

Wioletta Nowak

*University of Wrocław, Poland
wioletta.nowak@uwr.edu.pl*

ABSTRACT

The paper presents the scale of and trends in economic growth in the African, Caribbean, and Pacific (ACP) countries in the years 2002-2016. The study covers 48 African, 16 Caribbean and 15 Pacific countries and is based on the data retrieved from the World Bank Database. During the analysed 15 years, five African countries and Cuba had average annual GDP per capita growth rates higher than 4.0%. On the other hand, more than twenty ACP countries recorded negative or very low average annual GDP per capita growth rates. GDP in the fastest growing ACP countries has been primarily generated through services and industry sectors. Services and agriculture sectors have contributed the most to GDP in the slowest growing ones. The poorest countries were highly dependent on agriculture which provided a living for the vast majority of their population. On the demand side, domestic private consumption was the main source of growth in the analysed countries. Many countries experienced a decline in the share of exports of goods and services in GDP. Several ACP countries sustained growth mainly because of foreign aid. Resource rich countries managed to attract foreign direct investment. In some fast growing ACP countries, economic growth resulted from the implementation of market-based economic policies and improvement of investment framework and in other countries, government's interventionist policies enhanced it. The slowest growing ACP countries have been affected by conflicts, internal political turmoil and suffered from climate-related shocks. The vast majority of the analysed countries have to improve the business climate, governance, and control of corruption to maintain or accelerate economic growth.

Keywords: *ACP countries, economic development, economic growth, growth policy*

1. INTRODUCTION

Since the beginning of the twenty first century, several developing countries have recorded rapid economic growth and made significant progress in economic development. At the same time, other countries have experienced negative or very low average GDP per capita growth rates and slightly improved their development indices. The main aim of the paper is to show trends in economic growth in the African, Caribbean and Pacific Group of States (ACP Group) over the period from 2002 to 2016. The analysis is based on the data retrieved from the World Bank Open Data and comprises 79 countries. There are a lot of studies on economic growth and development in African, Caribbean and Pacific countries. For instance, economic growth in African countries was a subject of the study in Anyanwu (2014), Caceres and Caceres (2015), Onjala and K' Akumu (2016), and Oluwatayo and Ojo (2018). Mamingi and Borda (2015) focus on economic growth in the Caribbean countries and Connell (2011) in the Pacific. Nowak (2017a, 2017b) analyses economic growth and development in least developed countries. The main contribution of this paper to the discussion on economic growth in the twenty first century is a comparison of growth determinants on the supply and demand sides in the ACP countries using the same set of data.

2. THE FSTEST AND SLOWEST GROWING ACP COUNTRIES IN THE YEARS 2002-2016

The African, Caribbean and Pacific Group of States was formally created by the Georgetown Agreement and by the first Lomé Convention signed in 1975.

The ACP Group comprises 48 countries from sub-Saharan Africa (SSA), 16 from the Caribbean and 15 from the Pacific¹. It is a diverse group of states. The surfaces of ACP countries vary from 20 square kilometres (Nauru) up to 2 344.9 thousand square kilometres (Democratic Republic of the Congo). The population ranges from 11 thousand (Tuvalu) to 186 million (Nigeria), while the population density varies from 3.0 (people per sq. km of land area) in Namibia to 662.8 in Barbados. The size of 2016 GDP varies from US\$ 38 million (in 2010 constant US dollars) for Tuvalu to US\$ 457 billion for Nigeria and the 2016 per capita GDP ranges from US\$ 218.3 (2010 constant US dollars) in Burundi to US\$ 19 991.1 in Bahamas. The twenty countries are high ranked in the Human Development Index. Fourteen Caribbean, four Pacific and two African countries were classified as high human developed in 2015. Sixteen countries are medium human developed² and the remaining 43 ACP states are low human developed. In the years from 2002 to 2016, several ACP countries recorded high GDP growth. Ethiopia was the fastest growing economy in the considered group of countries³. The average annual GDP growth rate in the country was above 9%. It is worth noting that the Ethiopian economy grew faster in a shorter period. GDP growth rate in Ethiopia averaged 10.2 per cent between 2007 and 2016. During the analysed 15 years, high GDP growth rates were also observed in Rwanda, Mozambique, Nigeria, Tanzania, Uganda, Sierra Leone, Zambia, Ghana, and Democratic Republic of the Congo (DCR). Chad, Angola, and Equatorial Guinea had high average GDP growth rates because their economies grew very fast for few years i.e. Chad from 2002 to 2005, Angola from 2004 to 2008, and Equatorial Guinea before the global financial crisis. On the other hand, twelve ACP countries had average annual GDP growth rates below 2% in the years 2002-2016. The economy of Central African Republic (CAR) grew at rate -0.5% and the Zimbabwean economy at -0.4%. The economic performance of several ACP countries was even worse in a shorter period (Table 1). It is worth noting that the economy of Zimbabwe was contracting by around 9% per year from 2002 to 2008 and it recorded growth of more than 13% per year in the period 2009-2012.

Table following on the next page

¹ The ACP countries from **Sub-Saharan Africa** are the following: Angola, Benin, Botswana, Burkina Faso, Burundi, Cabo Verde, Cameroon, Central African Republic, Chad, Comoros, Congo, Côte d'Ivoire, Democratic Republic of the Congo, Djibouti, Equatorial Guinea, Eritrea, Ethiopia, Gabon, Gambia, Ghana, Guinea, Guinea-Bissau, Kenya, Lesotho, Liberia, Madagascar, Malawi, Mali, Mauritania, Mauritius, Mozambique, Namibia, Niger, Nigeria, Rwanda, São Tomé and Príncipe, Senegal, Seychelles, Sierra Leone, Somalia, South Africa, Sudan, Swaziland, Tanzania, Togo, Uganda, Zambia, and Zimbabwe, from **the Caribbean**: Antigua and Barbuda, Bahamas, Barbados, Belize, Cuba, Dominica, Dominican Republic, Grenada, Guyana, Haiti, Jamaica, St. Kitts and Nevis, Saint Lucia, St. Vincent and Grenadines, Suriname, and Trinidad and Tobago, and from **the Pacific**: Cook Islands, Fiji, Kiribati, Marshall Islands, Micronesia, Nauru, Niue, Palau, Papua New Guinea, Samoa, Solomon Islands, Timor-Leste, Tonga, Tuvalu, and Vanuatu.

²The following ACP countries: Barbados, Bahamas, Palau, Antigua and Barbuda, Seychelles, Mauritius, Trinidad and Tobago, Cuba, Saint Kitts and Navies, Grenada, Fiji, Saint Lucia, Jamaica, Dominica, Suriname, Dominican Republic, Saint Vincent and Grenadines, Tonga, Belize, and Samoa are in the group of "higher human development". Botswana, Gabon, South Africa, Cabo Verde, Namibia, Guyana, Micronesia, Timor-Leste, Vanuatu, Congo, Equatorial Guinea, Kiribati, Ghana, Zambia, São Tomé and Príncipe, and Kenya are medium human developed countries.

³Nauru grew at 17.4% per annum in the years 2008-2016. However, this small Pacific island is excluded from the analysis because the available data cover only nine years.

Table 1: Average GDP growth in the selected ACP countries, 2002-2016 (Source: Own calculations based on WBOD, 2018)

The fastest growing ACP countries			The slowest growing ACP countries		
Country	2002-2016	2007-2016	Country	2002-2016	2007-2016
Ethiopia	9.1%	10.2%	CAR	-0.5%	-1.7%
Rwanda	7.8%	7.6%	Zimbabwe	-0.4%	3.9%
Chad	7.3%	3.9%	Micronesia	0.01%	-0.1%
Angola	7.3%	6.3%	Bahamas	0.2%	-0.5%
Mozambique	7.2%	6.7%	Jamaica	0.7%	-0.1%
Nigeria	7.0%	4.9%	Barbados	1.1%	0.2%
Equatorial Guinea	6.9%	1.4%	Palau	1.2%	1.2%
Tanzania	6.8%	6.7%	Haiti	1.3%	1.9%
Uganda	6.7%	6.1%	Tonga	1.3%	1.4%
Sierra Leone	6.6%	4.9%	Marshall Islands	1.5%	1.5%
Zambia	6.6%	6.5%	Tuvalu	1.7%	2.4%
Ghana	6.4%	6.8%	Dominica	1.8%	1.5%
DRC	6.0%	6.3%	Kiribati	2.0%	2.2%

Over the period from 2002 to 2016, GDP growth ranged from 0.2% (Bahamas) to 5.3% (Dominican Republic) in the Caribbean countries and from 0.01% (Micronesia) to 4.9% (Papua New Guinea) in the Pacific ones. In the years 2007-2016, in the group of the Caribbean countries the lowest average annual GDP growth rate was also in Bahamas (-0.5%) and the highest in Dominican Republic (5.3%). GDP growth varied from -0.1% (Micronesia) to 7.8% (Timor-Leste) in the group of Pacific countries. Low GDP growth together with high population growth resulted in really low GDP per capita growth in many ACP countries (Table 2).

Table 2: Average GDP per capita growth in the selected ACP countries, 2002-2016 (Source: Own calculations based on WBOD, 2018)

The fastest growing ACP countries			The slowest growing ACP countries		
Country	2002-2016	2007-2016	Country	2002-2016	2007-2016
Ethiopia	6.2%	7.4%	Zimbabwe	-2.1%	1.7%
Rwanda	5.3%	4.9%	CAR	-1.7%	-2.6%
Nigeria	4.3%	2.2%	Bahamas	-1.5%	-2.0%
Cuba	4.3% (2002-2015)	3.1% (2007-2015)	Liberia	-0.7%	1.9%
Sudan	4.2%	4.2%	Madagascar	-0.4%	-0.1%
Mozambique	4.1%	3.6%	Gabon	-0.4%	0.6%
Dominican Republic	3.9%	3.9%	Comoros	-0.3%	-0.4%
Ghana	3.8%	4.2%	Burundi	-0.3%	-0.2%
Mauritius	3.7%	3.8%	Haiti	-0.2%	0.5%
Chad	3.7%	0.6%	Gambia	-0.1%	0.3%
Zambia	3.6%	3.4%	Kiribati	0.04%	0.3%

In the years 2002-2016, twenty two ACP countries had an average GDP per capita growth rate lower than 1% per annum. It is worth noting that in the shorter period (2007-2016), nearly 30 ACP countries had so low GDP per capita growth rate. During 15 years, the highest GDP per capita growth was observed in Ethiopia and Rwanda while between 2007 and 2016 in Ethiopia,

followed by Timor-Leste, and Rwanda. In sub-Saharan Africa GDP per capita growth ranged from -2.1% (Zimbabwe) to 6.2% (Ethiopia) in the years 2002-2016 and from -2.9% (Equatorial Guinea) to 7.4% (Ethiopia) in the shorter period. In the Caribbean countries GDP per capita growth varied from -1.5% (Bahamas) to 3.87% (Dominican Republic) over the period of 15 years and from -2.0% (Bahamas) to 3.94% (Dominican Republic) in the years 2007-2016. Among the Pacific countries the lowest average annual GDP per capita growth rate between 2002 and 2016 was in Kiribati (0.04%) and the highest in Papua New Guinea (2.5%). Over the period 2007-2016, GDP per capita growth ranged from -0.04% (Micronesia) to 5.7% (Timor-Leste) in the Pacific region.

3. DETERMINANTS OF ECONOMIC GROWTH IN SUB-SAHARAN AFRICA

In the fastest growing sub-Saharan African countries, except Chad, services are principal sources of GDP. In recent years, the services sector contributed more than 70% to GDP in Mauritius and more than 50% in Nigeria, Zambia, Mozambique, Ghana, Rwanda, and Sudan. Services, followed by agriculture have been generated GDP in Ethiopia, and agriculture, followed by services in Chad. The structure of GDP in Nigeria sharply changed in 2010. Between 2002 and 2016, the share of services in GDP increased by nearly 40 percentage points. At the same time the share of industry sector in GDP declined by 13 p.p. and agriculture by 27 p.p. The share of services in GDP increased by 20 p.p. in Sudan (at expense of industry sector) and in Ghana (at expense of agriculture). The structure of Sudan's GDP changed after the secession of South Sudan. In Ghana, agriculture was the mainstay of the economy in the years 2003-2005 due to the expansion of the cocoa subsector. The industry sector contributed nearly 37% to GDP in Zambia, 28% in Ghana, and about 20% in Mozambique, Ethiopia, Mauritius, and Nigeria in 2016. The agricultural sector generated 50% of GDP in Chad, 39% in Sudan, and 37% in Ethiopia. In terms of employment, agriculture has been a major sector in most SSA countries. More than 70% of population is employed in agriculture in Rwanda, Mozambique, Chad, Ethiopia, and Zambia. The agricultural sector employs more than half of the workforce in Nigeria, Sudan, and Ghana. The services sector provides the main livelihood for a vast majority of the population only in Mauritius. On the demand side, domestic private consumption has been the main source of growth in most SSA countries. The average share of household final consumption expenditure in GDP was less than 60% only in Zambia. The share of gross domestic investment (gross capital formation) in GDP more than 40% was observed in Ethiopia, Mozambique, and Zambia. The contribution of government final consumption expenditure to GDP was the highest in Mozambique. Exports of goods and services were very important source of foreign reserves in Mauritius. They were contributing more than 50% of GDP over the period 2002-2016. Exports generated more than 30% of GDP in Chad, Ghana, Zambia, and Mozambique. In Ethiopia, Rwanda, Sudan, and Nigeria the share of exports in GDP was low. Top exports of Mauritius are processed fish, raw sugar, and articles of apparel. Chad is an exporter of crude petroleum, gold and raw cotton. Ghana exports gold, cocoa and cocoa preparations, and crude petroleum. The Zambian exports are based on copper, pearls, precious stones, and corn. Top exports of Mozambique are aluminium, mineral fuels, oils, distillation products, tobacco, prawns, cashews, and cotton. Ethiopia exports coffee, tea, edible vegetables, pearls, and precious stones. Gold, tea, refined petroleum, coffee, and spices are basic export goods in Rwanda. Sudan exports gold, crude petroleum, precious stones, pearls, oil seed, grain, and live animals. Crude and refined petroleum, petroleum gas, cocoa beans, and gold are top exports of Nigeria. A positive trade balance has been observed only in Chad, and Zambia. Mozambique, Rwanda, and Ethiopia rely on foreign direct assistance (ODA). However, Mozambique's economy boomed not only on ODA but also on large inflows of foreign direct investment (FDI). In Nigeria, remittances are more important source of income than ODA or FDI (Table 3).

Table 3: Remittances, net ODA, and net FDI flows as per cent of GDP in the selected sub-Saharan African countries, 2002-2016 (Source: Own calculations based on WBOD, 2018 and OECDstat, 2018)

Country	Remittances	ODA	FDI	Country	Remittances	ODA	FDI
The fastest growing sub-Saharan African countries				The slowest growing sub-Saharan African countries			
Ethiopia	1.4%	11.7%	2.7%	Zimbabwe	7.1%	6.6%	1.5%
Rwanda	1.6%	17.9%	2.1%	CAR	n.a.	14.3%	1.8%
Nigeria	6.2%	1.5%	2.5%	Liberia	13.8%	71.1%	32.5%
Sudan	2.6%	3.6%	3.7%	Madagascar	2.3%	9.7%	6.1%
Mozambique	1.0%	19.3%	16.3%	Gabon	n.a.	0.6%	3.7%
Ghana	3.0%	6.8%	5.9%	Comoros	17.4%	10.2%	1.1%
Mauritius	0.01%	0.8%	2.6%	Burundi	1.1%	27.5%	0.7%
Chad	n.a.	6.1%	6.9%	Gambia	11.6%	12.4%	5.7%
Zambia	0.3%	9.1%	6.1%				

Note: Data on remittances for Burundi cover the period 2004-2016 and for Comoros and Gambia 2003-2016. Data on FDI inflows for Burundi cover the period 2004-2016.

Ethiopia has a planned economy. The state is heavily engaged in economy. In the years 2006-2015, the Ethiopian government implemented two national five-year plans to improve economic growth and reduce poverty i.e. the Plan for Accelerated and Sustained Development to End Poverty (2005-2010) and the Growth and Transformation Plan (2010-2015). They prioritised agricultural and export-led industrialisation. Economic growth in Ethiopia was driven by government investment in large-scale infrastructure projects (Grand Ethiopian Renaissance Dam on the Blue Nile River, railway line connecting Ethiopia to the Red Sea coast in Djibouti) and progress in the agricultural sector and services. Rwanda recorded high economic growth due to sound economic policies, peace and political stability. It made a great progress in improving business climate. Between 2008 and 2017, Rwanda implemented 49 different reforms, of which 44 making it faster and easier to do business WB (2018). The Nigerian economy relies on the oil sector. However, since the outbreak of the global financial crisis economic growth has been driven by growth in telecommunications, services, and agriculture. Before the secession of South Sudan, the oil sector had driven much of the Sudanese GDP growth. From 2012, Sudan has been developing gold mining and agriculture. In Mozambique, economic growth resulted from implementation of market-based economic policies and the improvement of investment framework. Most of the FDI flows were concentrated in mining, hydrocarbon and energy sectors. Mozambique's economy was also intensively supported by donors. Services contributed the most to GDP growth in Mauritius. The Mauritian economy grew primarily due to sound economic policies and a development of financial services, tourism, and information and communication technology. The economy of Chad is based on oil industry and agriculture. It grew very fast before the global crisis due to high oil prices. The expansion of cocoa sector and oil industry has boosted GDP growth in Ghana. Investment and human development were significant determinants of economic growth in Zambia (Mukupa, Lungu and Chibangula, 2016). In the slowest growing sub-Saharan African Countries, the services sector contributed more than 50% to GDP in Gambia, Zimbabwe, and Madagascar. GDP in Liberia has been generated through services, followed by agriculture while in Burundi and Central African Republic by the agricultural and services

sectors. Agriculture, including fishing, hunting, and forestry accounts for about 50% of GDP in Comoros. The industry and services sectors generate GDP in Gabon. In terms of employment, agriculture provides the main livelihood for more than 60% of the population in Central African Republic, Comoros, Gabon, Liberia, Madagascar, and Zimbabwe. In Burundi, above 90% of the population are engaged in agricultural activities. Only in Gambia a half of labour force is employed in the services sector. Gambia benefits from tourism and re-export trade. Travel and tourism account for 20% of the Gambian GDP and 17% of total employment. In Madagascar economic growth is driven by tourism (16% of GDP), construction, agriculture, and the extractive industries. The Liberian economy relies on production of the iron ore and agricultural sector led by rubber and timber exports. Burundi's agriculture is dominated by coffee, cotton and tea. Agriculture (the cultivation of food crops), forestry and mining remain the basis of the Central African economy. Agriculture, including fishing, hunting, and forestry, tourism, construction, and commercial activities constitute GDP of Comoros (Nowak, 2017b). The oil industry heavily affects Gabon's economic performance. The Zimbabwean economy depends on mining sector and export revenues. Due to political violence and human rights abuse Zimbabwe has been subjected to many sanctions from 2003. As a result, the economy experienced a deep recession and the worst hyperinflation of all time with the peak in 2008. The average share of household final consumption expenditure in GDP was more than 70% in all the slowest growing sub-Saharan countries, except Gabon. The gross domestic investment contributed to GDP more than 30% only in Gabon. The contribution of government final consumption expenditure to GDP was relatively high in Burundi. In the years 2002-2016, exports of goods and services generated more than 50% of GDP in Gabon. Exports were an important driver of growth in Liberia before the global crisis. Between 2002 and 2007, exports generated 60% of the Liberian GDP. In the years 2008-2016, the share of exports in GDP declined to 25% in that country. Exports of goods and services generated about 30% of GDP in Gambia, Madagascar, and Zimbabwe during the analysed 15 years. Exports were a small share of GDP in Burundi, Central African Republic, and Comoros. The top exports of Gabon are crude petroleum, manganese ore, and sawn wood. Liberia exports rubber, iron ore, gold, diamonds, and cocoa. Rough wood, coconuts, Brazil nuts, and cashews are exported by Gambia. Export income of Madagascar depends on vanilla, raw nickel, and clothing. Zimbabwe is an exporter of raw tobacco, gold, nickel ore, and diamonds. The top exports of Comoros are vanilla, cloves, and ylang ylang. Central African Republic exports rough and sawn wood, diamonds, and fruits. Burundi is an exporter of gold, coffee, tea, and wheat flours. In the years, 2002-2016, remittances contributed more than 17% to the Comoros' GDP. Money from diaspora have been important sources of income also in Liberia, and Gambia. Six out of eight slowest growing sub-Saharan African countries are aid-dependent. The share of FDI in GDP was the highest in Liberia (Table 3). To maintain or accelerate economic growth, the sub-Saharan African countries have to improve the business climate, governance, and control of corruption. The most favourable environment for business start-ups and entrepreneurs has been created in Mauritius and Rwanda. Mauritius is ranked the 25th out of 190 in the World Bank Group Flagship Report Doing Business 2018 and Rwanda ranks the 41st. The third country in the group of the analysed SSA countries which has the most business-friendly regulations is Zambia (the 85th). The remaining countries were very low ranked and their domestic firms face very costly and time-consuming process. For instance, Chad ranks the 180th and Central African Republic ranks the 184th (WB, 2018). Mauritius and Rwanda are countries with the best governance and Chad and Central African Republic with the poorest one (WGI, 2017). According to the 2017 Corruption Perceptions Index, Rwanda and Mauritius rank highest with scores of 55 and 50, respectively. Chad and Sudan rank lowest with scores of 20 and 16, respectively⁴ (CPI, 2017).

⁴ The Corruption Perceptions Index ranks countries on a scale of zero (highly corrupt) to 100 (very clean).

4. FACTORS OF ECONOMIC GROWTH IN THE CARIBBEAN AND PACIFIC COUNTRIES

In the Caribbean countries, GDP has been mainly generated through the services sector. Over the period 2002-2016, services contributed more than 80% to GDP in Barbados, Bahamas, and Saint Lucia, and more than 70% in Antigua and Barbuda, Grenada, St. Vincent and Grenadines, Cuba, St. Kitts and Nevis, Jamaica, and Dominica. The services sector accounted for more than 60% of GDP in Dominican Republic and Belize. More than 45% of GDP was generated by services in Suriname, Guyana, Haiti, and Trinidad and Tobago. The Barbadian economy is built on tourism and offshore banking. More than 70% of labour force are employed in the services sector. It is worth noting that construction sector has been one of main employers in Barbados. The economy of Bahamas is heavily dependent on tourism. The total contribution of travel and tourism to GDP was nearly 48% in 2017. Banking and international financial services constitute the second most important sector of the Bahamian economy. The services sector provides the main livelihood for 90% of the population in Bahamas. Tourism and offshore finance are also main drivers of the Saint Lucian economy. Antigua and Barbuda's economy heavily depends on tourism arrivals. Travel and tourism account for more than half of their GDP. Besides, offshore financial services and construction sector play important role in Antigua and Barbuda. Tourism and construction have become dominant economic activities in Belize, too. Like other Caribbean countries, Dominica, Jamaica, St. Kitts and Nevis, St. Vincent and Grenadines, and Grenada rely on tourism as the main source of their foreign reserves (Table 4).

Table 4: Share of travel and tourism in GDP and total employment of the Caribbean and selected Pacific countries in 2017 (Source: WTTC, 2018)

Country	% of GDP	% of total employment	Country	% of GDP	% of total employment
The Caribbean countries					
Antigua and Barbuda	51.8%	46.1%	Guyana	7.0%	7.4%
Bahamas	47.8%	55.7%	Haiti	9.7%	8.5%
Barbados	40.6%	40.5%	Jamaica	32.9%	29.8%
Belize	42.3%	37.3%	St. Kitts and Nevis	26.8%	25.6%
Cuba	10.7%	9.9%	Saint Lucia	41.8%	50.8%
Dominica	37.6%	34.4%	St. Vincent and Grenadines	23.4%	21.5%
Dominican Republic	17.2%	15.9%	Suriname	2.7%	2.5%
Grenada	23.3%	21.4%	Trinidad and Tobago	7.7%	9.9%
The Pacific countries					
Fiji	40.3%	36.5%	Solomon Islands	9.0	7.9
Kiribati	20.9%	17.3%	Tonga	18.2%	19.6%
Papua New Guinea	1.8%	1.6%	Vanuatu	44.5%	37.9%

Note: WTTC (2018) data are not available for all Pacific countries.

In the Caribbean region only a few economies are industrial. Economic growth in Trinidad and Tobago resulted from the rapid growth in the energy sector. Exports of oil and gas account for more than 40% of GDP. Trinidad and Tobago has been diversifying its economy and developing manufacturing industry, finance services, and tourism. The Dominican Republic's economy is based on free trade zone industry, tourism, and construction. The country has been developing manufacturing industry, communication sector, and financial services. A basis of the economy of Suriname is a mining industry. In the years 2002-2016, the Surinamese economy expanded on gold, oil, and alumina exports. It is dominated by state-owned enterprises and more than half of workforce is employed in the public sector. The Guyanese economy is based on agriculture (sugar, rice) and extracting industries (gold, bauxite). GDP of Haiti has been generated primarily through banking, electricity, telecom services, textiles, sugar refining, and construction industry (Nowak, 2017b). In contrast with other Caribbean countries, Cuba has a planned economy with state-owned enterprises and most of Cuban labour force is employed by the state. From 2011, the Cuban government has been implementing limited economic reforms. Cuba's services sector is based on tourism, retail, and finance. The agriculture is dominated by sugarcane, tobacco, rice, and tropical fruits. Cuba is famous of its biotechnology and pharmaceutical industries. In terms of employment, services sector has been a major sector in the Caribbean countries. On the demand side, household private consumption accounted for 90% of GDP in Haiti and more than 70% in Jamaica, Saint Lucia, and Dominican Republic. The share of gross domestic investment in GDP was really high in Suriname. It accounted for 66% of the Surinamese GDP in 2016. The gross domestic investment generated 30% of GDP in Haiti and Guyana. The highest contribution of government final consumption expenditure to GDP was observed in Guyana (17%). The main feature of the analysed countries is their high openness to international trade. In the years 2002-2016, exports of goods and services were an important driver of growth in Guyana (61.5% of GDP), Trinidad and Tobago⁵ (57.8%), Belize (57.7%), Antigua and Barbuda (47.8%), Suriname (44.9%), Saint Lucia (42.7%), Bahamas (41.6%), Barbados (41.3%), and St. Kitts and Nevis (40.1%). The share of exports of goods and services in GDP was smaller in Dominica (38.1%), Jamaica (34.2%), Grenada (32.8%), St. Vincent and Grenadines (31.9%), Dominican Republic (28.1%), Cuba (19.7%) and Haiti (16.0%). Between 2002 and 2016, the share of exports in GDP declined in eight countries (Antigua and Barbuda, Bahamas, Barbados, Dominican Republic, Guyana, Jamaica, Saint Lucia, and St. Vincent and Grenadines). All Caribbean countries, except Trinidad and Tobago, and Suriname, recorded a trade deficit. They mainly imported mineral fuels and oils, and refined petroleum (Antigua and Barbuda, Bahamas, Barbados, Belize, Cuba, Dominican Republic, Grenada, Guyana, St. Kitts and Nevis, Saint Lucia) and food (Cuba, Haiti, Saint Lucia). The main export commodities were the following: petroleum gas, and mineral fuels (Trinidad and Tobago), refined petroleum (Saint Lucia, Trinidad and Tobago), precious metals, inorganic chemicals, and aluminium ore (Jamaica), gold, and aluminium oxide (Suriname), aluminium ore, pearls, and precious stones (Guyana), nickel (Cuba), bananas (Dominica), sugar, fruit, and nuts (Belize, Guyana, Cuba), nutmeg, fish (Grenada), beverages (Barbados, Cuba), apparel, and manufactures (Haiti), pharmaceutical products (Barbados), electrical and electronic equipment (Dominican Republic), and passenger and cargo ships and boats (Antigua and Barbuda, Dominica, St. Kitts and Nevis, St. Vincent and Grenadines). The United States are the major trading partner for all Caribbean countries, except Cuba. Bahamas and Dominican Republic are dependent on trade with the US. The Caribbean countries, except Haiti, do not benefit much from official development assistance and are not aid-dependent. Remittances from diaspora have been important sources of income in Haiti, Jamaica, Guyana, and Dominican Republic. Several countries have managed to attract foreign direct investment (Table 5).

⁵ Data for Trinidad and Tobago, Belize, Barbados, and Cuba cover the period 2002-2015.

Table 5: Remittances, net ODA, and net FDI flows as per cent of GDP in the Caribbean and Pacific countries, 2002-2016 (Source: Own calculations based on WBOD, 2018 and OECDstat, 2018)

Country	Remittances	ODA	FDI	Country	Remittances	ODA	FDI
The Caribbean countries							
Antigua and Barbuda	1.8%	0.6%	12.2%	Haiti	22.8%	14.8%	1.3%
Barbados	2.7%	n.a.	6.5%	Jamaica	15.5%	0.5%	5.1%
Belize	4.7%	1.9%	7.3%	St. Kitts and Nevis	5.0%	n.a.	16.1%
Dominica	5.9%	5.2%	6.0%	Saint Lucia	2.2%	1.8%	9.6%
Dominican Republic	8.1%	0.3%	3.9%	St. Vincent and Grenadines	4.2%	2.5%	14.0%
Grenada	3.9%	3.3%	10.6%	Suriname	0.4%	1.9%	-1.6%
Guyana	14.0%	8.8%	6.8%	Trinidad and Tobago	0.6%	n.a.	3.2%
The Pacific countries							
Fiji	5.2%	2.2%	7.9%	Solomon Islands	1.8%	34.8%	6.6%
Kiribati	10.1% (2006-2016)	17.9%	0.4%	Timor-Leste	6.5% (2006-2016)	13.5%	2.5%
Marshall Islands	14.8% (2005-2016)	29.3%	6.4%	Tonga	26.9%	14.1%	2.5%
Micronesia	n.a.	36.2%	0.9%	Tuvalu	17.9%	42.4%	1.3%
Palau	0.9% (2005-2016)	14.2%	6.5%	Vanuatu	2.0%	12.7%	6.1%
Papua New Guinea	0.1%	5.4%	0.6%				

Note: WBOD (2018) data for Bahamas, Cuba, Cook Islands, Nauru, Niue, and Samoa are not available. Data on ODA for Papua New Guinea and Vanuatu cover the period 2002-2014 and for Timor-Leste 2002-2015.

In the group of the Caribbean countries, Jamaica and Samoa have created the most favourable environment for business start-ups and entrepreneurs. Jamaica is ranked the 70th out of 190 countries and Samoa ranks the 87th. On the other hand, Suriname ranks the 165th and Haiti ranks the 181st (WB, 2018). The least corrupted country is St. Vincent and Grenadines (score 58). Moreover, Dominica, Saint Lucia and Grenada achieved score above of 50. Haiti and Dominican Republic have a big problem with corruption (CPI, 2017). Most Caribbean countries have high quality of national governance. Barbados and Bahamas are ranked the highest in the World Bank's Worldwide Governance Indicators ranking. Belize, and first of all Haiti have poor governance (WGI, 2017). In the years 2002-2016, GDP in the Pacific countries has been largely generated through the services sector. Services accounted for nearly 80% of GDP in Palau, and Cook Islands, and more than 60% in Marshall Islands, Fiji, Micronesia, Tuvalu, Samoa, Tonga, and Nauru. The services sector contributed more than 50% to GDP in Solomon Islands, Vanuatu and Kiribati. Industry followed by services have been generated GDP in Papua New Guinea and services followed by industry in Niue. The industry sector was the main driver of growth in Timor-Leste (ADB, 2017 and UNCTAD, 2017)⁶. The Palauan economy consists mainly of tourism and fishing. Earnings from fishing licences generate income in Kiribati. Offshore financial services and tourism form the basis of Vanuatu's income. Tourism and offshore financial services are also the basis of the Cook Islander economy. Offshore financial services are source of income for Marshall Islands, too. The Fijian economy is primarily based on tourism (Table 4). The economies of Samoa and Tonga depend on tourism, agriculture and fishing. The services sector in Timor-Leste is dominated by public administration, retail and wholesale trade, and real estate activities.

⁶ According to WBOD (2018), services accounted for more than 60% of total gross value added in Timor-Leste in the years 2006-2015.

The public sector is the largest employer in Micronesia and dominates economic activity in Tuvalu. Tuvaluans make a living primarily through exploitation of the sea. Solomon Islands' economy is based on primary commodities and rests on mining, agriculture, and fishing. The Papua New Guinean economy consists of a small formal sector (minerals and energy extraction) and a large informal one (agricultural, forestry, and fishing sector) which employs most of the labour force. The Nauruan economy is based on phosphate mining. Most of labour force is employed in the mining industry and public administration. Niue's industry consists of small factories for processing fruits. Most people in Niue works on family plantations. Generally, industry in the small Pacific countries is limited to fish and fruit processing, and handicrafts. In terms of employment, the services sector or services, followed by agriculture (Fiji) employ most labour force in the Pacific countries. Agriculture provides a subsistence livelihood for more than 80% of population in Papua New Guinea, above 70% in Solomon Islands, and 60% in Samoa and Vanuatu. In Timor-Leste labour force is mainly employed in oil industry sector and services. On the demand side, the household private consumption accounted for 80% of GDP in Fiji and 60% in Palau. In the group of the Pacific countries, the gross domestic investment and government final consumption expenditure were the most important components of GDP in Palau and Fiji. Over the period 2002-2016, international trade was very important to the economy of Fiji (53% of GDP), Palau (51%), Vanuatu (45%), and Solomon Islands (43%). In the remaining Pacific countries, the share of exports in GDP ranged from 7.7% in Timor-Leste to 28.6% in Samoa. Between 2002 and 2016, the share of exports in GDP decreased in Fiji, Kiribati, and Timor-Leste. The top exports of Fiji, Micronesia, Kiribati, Cook Islands, Samoa are fish. Palau exports shellfish and tuna. Copra and coconut oil are main export goods of the Marshall Islands. Niue is an exporter of fruit juice and fish. Fish, vanilla, coconuts, Brazil nuts, and cashews are exported by Tonga. Tuvalu and Vanuatu exports boats and fish. Exports of Nauru are based on phosphates. Papua New Guinea exports petroleum gas, gold, rough wood, crude petroleum, and copper ore. Main exports of Solomon Islands are rough wood, palm oil, and fish. Timor-Leste exports primarily crude petroleum and coffee. All the Pacific countries, except Papua New Guinea and Solomon Islands, have trade deficit. Remittances and/or foreign aid are main sources of income in the small Pacific countries. Worker's remittances contributed the most to economic growth in Tuvalu (Tuvaluans work in Nauru in phosphate mining industry), Micronesia, Solomon Islands, and Marshall Islands. Tuvalu, Micronesia, and Solomon Islands are almost entirely dependent on foreign aid (Table 5). Australia is a major donor to Fiji, Kiribati, Nauru, Papua New Guinea, Samoa, Solomon Islands, Timor-Leste, Tonga, Tuvalu, and Vanuatu. The United States provide aid primarily to Marshall Islands, Micronesia, and Palau. Cook Islands and Niue are mainly supported by New Zealand. It is worth nothing that the Pacific states are also financed by China mainly in order to isolate Taiwan which currently maintains official relations with Kiribati, Marshall Islands, Nauru, Palau, Solomon Islands, and Tuvalu (Nowak, 2015). The share of FDI in GDP is bigger than the share of ODA or remittances only in Fiji. In the group of the Pacific countries, Samoa (the 87th), Tonga (the 89th), and Vanuatu (the 90th) have the best business climate. Samoa, Palau, and Nauru have also the highest quality of governance. On the other hand, Marshall Islands, Papua New Guinea, and Solomon Islands have a problem with governance. The Corruption Perceptions Index 2017 ranges from 29 in Papua New Guinea to 43 in Vanuatu.

5. CONCLUSION

GDP growth rate averaged seven per cent or above in several sub-Saharan African countries between 2002 and 2016. On the other hand, the economies of Zimbabwe and Central African Republic have contracted. The economies of SSA countries grew mainly due to political stability, sound economic policies, and improvement in business climate. In Ethiopia, the state has been heavily engaged in economy.

The slowest growing ACP countries have been affected by conflicts, internal political turmoil and suffered from climate-related shocks. The vast majority of SSA countries have to improve the business climate, governance, and control of corruption to maintain or accelerate economic growth. Over the period 2002-2016, Dominican Republic was the fastest growing economy in the Caribbean. In the Pacific, Timor-Leste experienced high growth in the years 2007-2016. The Dominican Republic's economic growth was boosted by development of free trade zone industry. The economy of Timor-Leste was growing due to expansion of oil sector and government expenditure on basic infrastructure, including electricity and roads. Economies of the Caribbean countries are mainly diversified into tourism and finance. Several countries are offshore tax havens. Half of countries are dependent on tourism. Besides, they are highly open economies. The Caribbean countries were hit by effects of the global financial crisis. They suffered from a sharp decline in tourism and a rise in debt. The Caribbean countries remain vulnerable to external shocks including natural disasters, volatile tourism receipts, changes in international oil and mineral prices. The Pacific countries' economic growth is hindered by geographic isolation, remoteness from international markets, limited size of domestic markets, lack of natural resources, vulnerability to natural disasters, and inadequate infrastructure. Small countries with limited natural resources and a narrow economic base are extremely vulnerable to external shocks.

LITERATURE:

1. ADB (2017). *Key Indicators for Asia and the Pacific 2017*. Retrieved 03.06.2018 from <https://www.adb.org/publications/key-indicators-asia-and-pacific-2017>
2. Anyanwu, J.C. (2014). Factors affecting economic growth in Africa: Are there any lessons from China? *African Development Review*, 26(3), 468-493.
3. Caceres, L.R. and Caceres, S.A. (2015). Financing investment in sub-Saharan Africa: Savings, human development, or institutions? *Journal of Developing Areas*, 49(4), 1-23.
4. Connell, J. (2011). Elephants in the Pacific? Pacific urbanisation and its discontents. *Asia Pacific Viewpoint*, 52(2), 121-135.
5. CPI (2017). *Corruption Perceptions Index 2017*. Retrieved 30.05.2018 from https://www.transparency.org/news/feature/corruption_perceptions_index_2017
6. Mamingi, N. and Borda, P. (2015). The Determinants of Economic Growth in Countries of the OECS. *Journal of Eastern Caribbean Studies*, 40(2), 63-98.
7. Mukupa, G.M., Lungu, A. and Chibangula, S. (2016). An empirical analysis of the determinants of economic growth in Zambia: 1973-2013. *World Journal of Research and Review*, 2(5), 69-73.
8. Nowak, W. (2015). China's Development Aid Strategies. *Chinese Business Review*, 14(4), 201-209.
9. Nowak, W. (2017a). Economic development in Asian least developed countries. In: M. Cingula, M. Przygoda and K. Detelj (Eds.) *Economic and Social Development (Book of Proceedings)*, 23rd International Scientific Conference on Economic and Social Development, Madrid, 15-16 September 2017.
10. Nowak, W. (2017b). Growth disasters in least developed countries. In: V. Potocan, P. Kalinic and A. Vuletic (Eds.), *Economic and Social Development (Book of Proceedings)*, 26th International Scientific Conference on Economic and Social Development – „Building Resilient Society”, Zagreb, 8-9 December 2017.
11. OECDStat (2018). *Aid (ODA) disbursements to countries and regions [DAC2a]*. Retrieved 02.06.2018 from <http://stats.oecd.org/Index.aspx?DataSetCode=Table2A>
12. Oluwatayo, I.B. and Ojo, A.O. (2018). Walking through tightrope: The challenge of economic growth and poverty in Africa. *Journal of Developing Areas*, 52(1), 59-69.

13. Onjala, J. and K'Akumu, O.A. (2016). Rational patterns of urbanisation and economic growth in sub-Saharan Africa. *Development Southern Africa*, 33(2), 234-246.
14. UNCTAD (2017). *The Statistical Tables on Least Developed Countries – 2017*. Retrieved 03.06.2018 from http://unctad.org/en/PublicationsLibrary/ldc2016_Stats_en.pdf
15. WB (2018). *Doing Business. Measuring Business Regulations*. Retrieved 30.05.2018 from <http://www.doingbusiness.org/reports/global-reports/doing-business-2018>
16. WBOD (2018). *World Bank Open Data*. Retrieved 30.05.2018 from <http://data.worldbank.org/>
17. WGI (2017). *Worldwide Governance Indicators, 2017 Updated*. Retrieved 30.05.2018 from <http://info.worldbank.org/governance/wgi/#home>
18. WTTC (2018). *Travel and Tourism. Economic Impact 2017*. World Travel and Tourism Council. Retrieved 01.06.2018 from <https://www.wttc.org/>

MODERN GOING FOR CORPORATE MANAGEMENT AND ITS FEATURE ENTERPRISES IN UKRAINE

Azhaman I. A.

*Odessa State Academy of Civil Engineering and Architecture, Ukraine
ag_irisya@ukr.net*

Klyuchnik A. V.

*Mykolayiv National Agrarian University, Ukraine
klyuchnik.alena2408@gmail.com*

Telichko N. A.

*Odessa State Academy of Civil Engineering and Architecture, Ukraine
sklnata@ukr.net*

ABSTRACT

In the article is a research modern approach in relation to determination of conception of corporate management enterprises in Ukraine. It is set on the basis of their generalization, that a corporate management is the difficult phenomenon, which it is expedient to examine both in wide and in a narrow value; from point of partial, normative, economic financial, administrative-organizational, legal, public and socio-economic approaches. Principles of corporate management in Ukraine are based on the basis of general, and also the specific which take and include into account the national features of corporate sphere of management. Last approval by the State commission on securities and share market of Ukraine, and presented in such blocks, as: purpose of society; rights for shareholders; observant advice and executive branch; opening of information and transparency; control for financially and economic by activity of society and the interested persons. Also in the article there are certain descriptions of corporate form of business, to which is taken: independence of enterprise as a legal entity; limited liability of individual investors; possibility of transmission for other persons the actions which belong to the individual investors; centralized management. The introduce decryption of basic units of corporate management in Ukraine. There are allocations an object and a subject, and also basic subjects of corporate management. It is taken to the last: issuers, investors or shareholders, management and workers of enterprise, state in the person of public and organs of local self-government, creditors, other interested persons authorities, what enterprises of corporate type involved in the process of functioning. Taking into account traffic of corporate rights regulation such entities of corporate management as: citizens-proprietors of corporate rights; proprietors and management of enterprise - issuer of corporate rights, or their proprietor; public and non-state organs and others like that. There are determined basic functions of corporate management – planning, organization, coordination, control, and motivations which are considered from point of corporate management rights and also from point of management of corporation. Spared attention the question of becoming and development of the Ukrainian model of corporate management, in which takes place are combination of elements of insider and outsider models.

Keywords: *corporate management, corporate case frame, approaches, principles and functions, component elements*

1. ENTRY

Development of market's relations in Ukraine assisted appearance of different legal forms of enterprises, the special place among there are occupied by joint-stock company of the closed and open type, company with limited liability and others like that.

On such enterprises the mutual relations are formed between their participants - proprietors - shareholders, management, workers and other subjects. All of it causes the necessity of application of the system's rules and principles which will provide such management and control above a company, that will take in a most measure into account are interests of shareholders and other stakeholders, including are workers, clients and suppliers. A modern corporate management shows such system a soba the company. Will notice, that the observance of high standards of corporate management takes on the special significance in the globalization's context and euro integration's processes and there is a requirement of investors to the potential partners, and improves possibilities in bringing of investments. Understanding of ponderability, and accordingly, the increase of investor's interest, state supervision's organs, society, shareholders and management, companies' personnel to the corporate management determines actuality researches of essence and value of this phenomenon, and also determination of his features on the enterprises corporate's type in Ukraine.

2. MODERN GOING IS FOR DETERMINATION OF CORPORATE MANAGEMENT IN UKRAINE

Interpretation of concept "corporate management" depends on the approaches, used by different authors, that is mortgage in essence of this concept certain aspects and for that can be based basic principles of corporate management:

- this is based on normative positions and menage's practices;
- the provides protection of rights for investors and corporate control;
- the decides contradictions between shareholders and management of corporation;
- uses institutional mechanisms for effective work of enterprise and management of property relations

The essence corporate's management research by us was begun with the study of normatively-legal base, that interprets are basic terms related to the corporate management. So, in the Commercial code of Ukraine is examined the concept of corporate enterprise. Marked, that in Ukraine depending on the method of founding and forming of charter capital enterprises operate unitary and corporate. The corporate enterprise appears, as a rule, by two or anymore founders after for their general decision (by an agreement), operates on the basis of association of property and/or entrepreneurial or environment servicing activities of founders (participants), and theirs general administrative department, on the basis of corporate laws, which including through organs, that created by them, to participating of founders (participants) in allocation of enterprise's profits and risks. There are corporate are co-operative enterprises and enterprises that is created in form economic society, and also other enterprises including based on a peculiar two or more persons. Also in the marked code to concept determination the corporation points. It is marked that the corporation is a contractual association, created on the basis of combination of productive, scientific and commercial interests of enterprises that united, with delegation by them separate plenary powers of the centralized adjusting of activity each of participants to the of management's organs of corporation. Business enterprises are appearing as associations, corporations, consortia, business concerns, other associations of enterprises, as statutory. State and municipal enterprises and associations appear mainly in form corporation or business concern, regardless of the name of association (combine, trust and others like that) [1]. The determination to the concept of the corporate laws is given in the internal revenue code of Ukraine. The last are examined as rights for personality part of that is determined in the charter capital (property) of business entity, that include competence on participating of this person in a management business entity, receipt of certain share of profits (dividends) of this business and assets in case of liquidation last under the law, and also other to the competence, statutory and by regulation documents. Also there are certain in a code such terms as revenue, dividends,

share premium, investments, including are capital, financial, direct, portfolio investment [2]. In the law of Ukraine "On joint-stock companies" is also brought determination of "corporate laws". The last is interpreted as totality of property and unproperty rights for a shareholder - stock of society, that swim out from the right of ownership on actions, that include a right on participating in a management a joint-stock company, drawing dividends and assets of joint-stock company in case of his liquidation under the law, and also other rights, and to the competence, holder, statutory or by regulation documents [3]. It was set on the basis of study legislatively-normative's documents, that on this time in Ukraine it is not formed only going near understanding of essence of concepts corporate laws, corporate relations, corporate management. The marked underlines the necessity of further improvement of legislatively-normative base in relation to these questions and grounds expediency of scientific researches in this direction. Deserves attention the experience of foreign scientists that in the time began research in relation to determination of essence of corporate management. Also, at the beginning of 30th of XX of century are Adolf Berle and Gardiner Means came to the conclusion, that control interests above a corporation radically different from interests possessing property of corporation and thus interests of proprietors of capital and managers, that manage him does not coincide [4]. In 1937 Ronald Harry Coase worked out the contract theory of firm, in that offered permission of conflict of interests, that arises up between proprietors and managers, through by the conclusion of corresponding contract, where all rights and terms of collaboration of parties are illuminated [5, c. 386–405]. A next step to the decision of questions in relation to a management corporations development became in 70th of XX of century by Michael C. Jensen and William H. Meckling theories of agent charges are determination of size of losses for investors, that is related to distribution of ownership and control rights [6, c. 118–191]. Peter Ferdinand Drucker, studying this question in 1945 marked that a corporate management is oriented to creation of such frames case corporations in that shareholders would realize right and duties really [7]. M. Jensen and W. Meckling marked that an effective corporate case frame must be built thus, to minimize agent charges, abandoning valuable corporate control after shareholders. Colin Mayer examines a corporate management as organizational agreement in obedience to that a company presents and serves interests of the investors [8, c. 25]. The specialists of IFC determine a corporate management as system of the elected and appointed bodies of joint-stock company, that manages him, removes balance of interests of his proprietors and sent to the receipt of maximally possible profit from all types of activity of society within the limits of current legislation [9, c. 90]. As a system of electoral and appointed organs a corporate management is examined A. Kozachenko, A. Voronkova, A. Korenev [10]. Corporate management as organizational model by means of that there are and are on the defensive interests of investors examine E. Gubin, T. Kashanina, G. Vechkanov, V. Pulyaev examine a corporate management as certain organizational agreement that can embrace the different aspects of activity of corporation. From the point of view of protection of rights for investors and corporate control a corporate management is examined by V. Kondratyev, Y. Kurenkov, A. Povaznyi. Reasonable approach in obedience to that a corporate management is examined from position of mutual relations between the different participants of corporations [10 - 13]. In a narrow value a corporate management it is expedient to examine as a certain mechanism of management and distribution of power between the different groups of participants of corporate relations. In a wide value is totality of relations between a corporation and society. On the basis of generalization of researches in relation to essence of corporate management there was the distinguished row of approaches in relation to interpretation of corporate management Figure 1.

Figure following on the next page

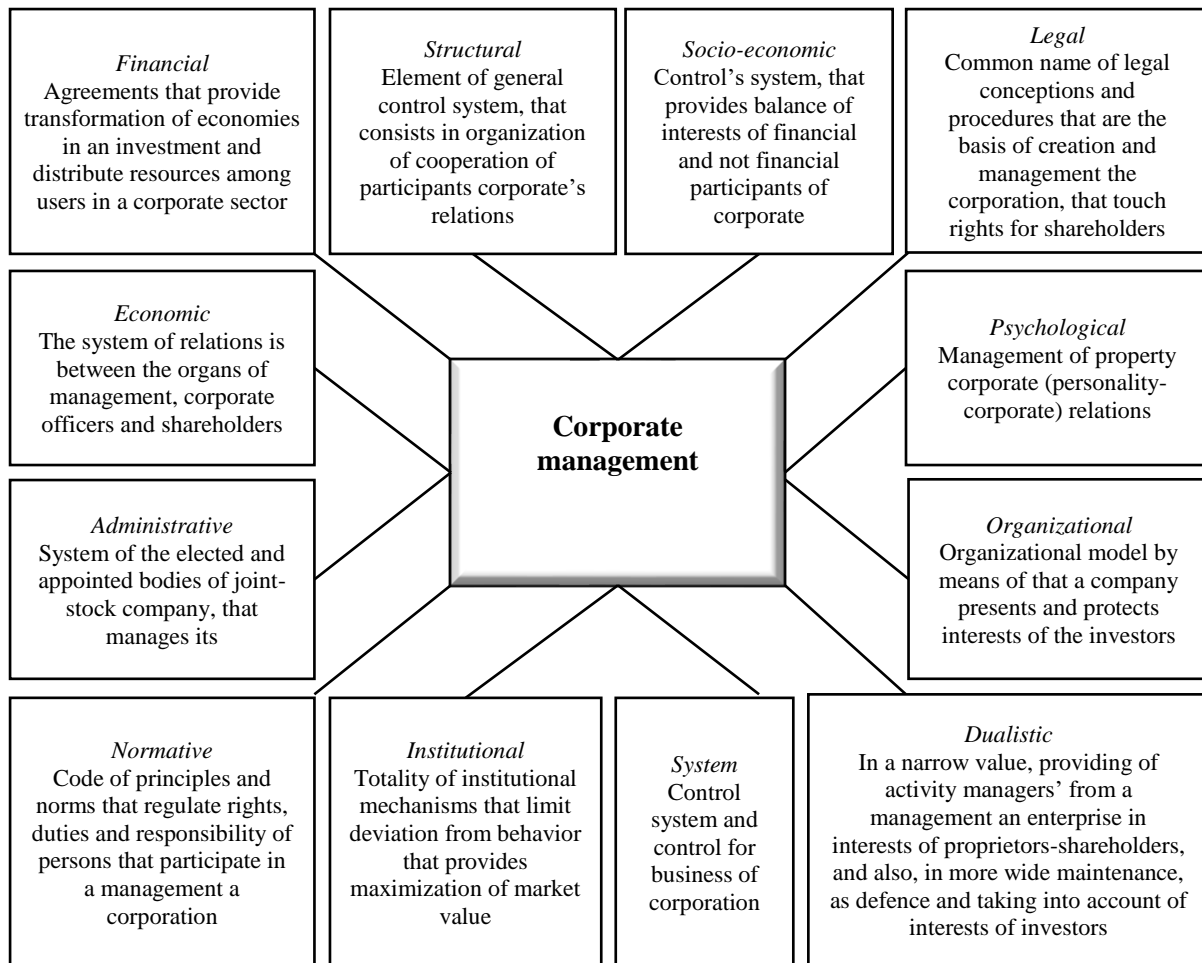

Figure 1. Going is near determination of essence of corporate management

As a result of research the essence of corporate management in scientific literature it was set, that there is understood as an operating method on the system of mutual relations between the participants of corporate relations, that is regulated by legislative and normative acts, by internal normative documents for the increase of efficiency of manage - receipt of the expected profit. In our view, a corporate management can be examined as a management corporate law. It determination is very wide and testifies that the proprietor of such rights has a right of ownership on part in the charter capital of economic society, including rights on a management, receipt of share of corresponding profits of society and also on part of assets in case of liquidation of this subject of manage. From this point of view a corporate management shows a soba the processes of adjusting of motion of it's a proprietor corporate laws with the aim of receipt of profit and management an enterprise. Or, in other words, it is possible to say, that a corporate management is the system of relations between the organs of society and his proprietors (by shareholders) in relation to the management of society activity. The system of corporate management shows a soba an organizational model by means of that an enterprise presents and protects interests of the investors. This system contains elements, beginning from the board of directors to the charts of labor's remuneration of executive link and mechanisms of filing a petition for bankruptcy. The type of the applied model depends on a corporate's structure, which exists within the framework of market economy and represents the fact of division of possession's functions and management at the modern corporation. In the wide understanding a corporate management is examined as a system by means of that direct and control activity of society. It is determined within the framework of corporate management, how investors carry out control for the activity of managers and also what responsibility is born

the by managers before investors for the results of activity of society. The proper system of corporate management allows to the investors to repose in that guidance of society reasonably uses them to the investment for financially-economic activity and thus the cost of part of investor's increases in the capital of society. The proper corporate management is not limited to exceptionally the relations between investors and managers, but envisages also taking into account of legal interests and active collaboration with the interested persons that have legitimate interest in activity of society (by workers, consumers, creditors, by the state, by public and others like that). It is related to that society can't exist regardless of society it functions in that and eventual success of his activity depends on payment of all interested persons. Thus, corporate business management's essence is the system of relations between investors - proprietors of business, his managers and also of interested persons for providing of effective activity of business, equilibrium of influence and balance of interests of participants of corporate relations. Importance of corporate management for societies consists in its payment to the increase of their competitiveness and economic efficiency due to providing: the proper attention to interests of shareholders; equilibrium of influence and balance of interests of participants of corporate relations; financial transparency; input of rules of effective management and proper control. Importance of corporate management for the state is conditioned by its influence on social and economic development of country through:

- It is assistance to development of investment processes, providing of confidence and increase of investor's trust;
- It is an increase of efficiency of the use of capital and activity of enterprises;
- taking into account of interests of wide circle of the interested persons, which provides realization of enterprise's activity for the good of society and increase of national riches.

The most attractive for investors in Ukraine there are four descriptions of corporate business' form: independence of enterprise as a legal entity; limit liability of individual investors; possibility of transmission to other persons of actions that belong to the individual investors; centralized management.

3. DESCRIPTION OF ELEMENTS, PRINCIPLES AND FUNCTIONS OF CORPORATE'S MANAGEMENT

3.1. Corporate custom controls are in Ukraine

Main function of corporate management in Ukraine - to provide work of corporation in interests of shareholders, that gave corporations financial resources and also in interests of other interested persons. The object of corporate management is a corporation. The objects of corporate management are business enterprises. However is not all a business enterprise gets under for the concept of corporate. First of all, to them takes joint-stock companies, societies with a limit and additional responsibility, id est. those in that a management is dissociated from property. The object of corporate management is also the state property, passed in the charter capitals of business enterprises, action of joint-stock companies that belong to the state. Public relations that is folded between the participants of corporation come forward as the article of corporate management, between a corporation and management, between the different organs of management in the process of becoming, activity and liquidation of corporation. So as a concept "corporate management" shows a soba the system of internal relations - between the organs of society and his shareholders, and relations external - between society and by any other third persons. Thus, as participants of corporate relations come forward: issuers - as a rule, it is joint-stock companies; investors or shareholders; management of enterprise; the state is in the person of public and organs of local self-government authorities; creditors, other stakeholders. If in the system of corporate management for a base element to take all corporate laws, then it is expedient coming from it to define also his subjects.

First of all, the direct proprietors of corporate laws come forward as subjects of corporate management. Such today are citizens, legal entities, state. These subjects are the proprietors of corporate laws and carry out their traffic regulation. Thus, the corporate management comes true by separate citizens, organs of government control and also at the level of separate enterprises - issuer corporate's laws. A key figure in composition the participants of corporate relations is an issuer. Exactly issuers of securities are the consumers of investments, which of them get by producing of securities. Exactly they unite persons that invest money and property in securities of issuer. Shareholders enter with a corporation in the special relations: they do possible self-existence of corporation as suppliers of "risk" capital, necessity for her origin, development and increase. Thus, as subjects of corporate management, from one side, the proprietors of corporate laws come forward. However they are not single, as such the objects are not only proprietors and but also other states, workers of corporate enterprises et al. From the point of view of corporate's laws traffic regulation there are clearly certain subjects of corporate management : separate citizens are proprietors of corporate laws; proprietors and management of separate enterprise - issuer of corporate laws or their proprietor; public and non-state organs that carry out direct or mediated traffic of corporate laws and activity of enterprises regulation. In particular, business enterprises and also are the proprietors of both integral property objects and corporate laws.

3.2. Principles of corporate management are in Ukraine

For basis of forming of principles of corporate management international experience of management of the world corporations and general principles of corporate management, worked out by The Organisation for Economic Co-operation and Development (OECD), European Bank for Reconstruction and Development (EBRD) are fixed in Ukraine and also certain on the European Confederation of Directors' Associations (ecoDa) [14, 15]. Consequently, OECD is worked out 23 principles of the corporate management; however not all of them are used and operate in the Ukraine. Concordantly to Decree of President of Ukraine "About events in relation to development of corporate management in the joint-stock companies" of 2002 The State commission on securities and fund market confirmed national principles of corporate management. Home principles of corporate management contain key principles on the basis of that corporate's relations in Ukraine and certain recommendations must develop in relation to a quality and transparent management. On results an analysis it is possible to distinguish basic principles of corporate management that it is expedient to unite in such blocks: protection of rights for shareholders, participation of the interested persons, opening of information, absorption of company and protective events, company management, audit and accounting control. Principles of corporate management in Ukraine also include specific that take into account the national features of corporate sphere of management, last approval by a state commission on securities and fund market of Ukraine and presented in such blocks, as an aim of society; rights for shareholders; review supervisory board and executive branch; opening of information and transparency; control after financially-economic activity of society and interested persons. Among marked basic are: leading role of review broker's in a management a joint-stock company; a presence of independent members of review supervisory board are in the joint-stock companies; external control for activity of review supervisory board and officers of a company.

3.3. Functions of corporate management

The functions of corporate management can be examined depending on the objects of management. Foremost, management's functions arise up at the management's corporate laws and have a certain feature here. Secondly, the functions of corporate management exist at a management of corporation as by a specific legal entity.

Thirdly, the functions of corporate's management exist at an economics' management the corporation as by organization. It is such functions on a production, which execute productive subdivisions (management of basic, auxiliary operations, marketing, finances, quality, innovations, by a personnel and other). In a general view distinguish such functions as: planning, organization, coordination, control and motivation. To the specific functions of corporate's management it is expedient to take: realization of primary and derivative emissions, traffic of corporate securities regulation at the fund market, adjusting of realization of general collection, forming of management's organs between general collection and grant to them of certain plenary powers, work is with financial mediators, organization of depositary and registration activity, organization of payment of dividends, acquaintance of shareholders with information, reorganization of corporation and other.

3.4. Becoming and development of the Ukrainian corporate management

Becoming and development of the Ukrainian's corporate case frame takes place taking into account world experience of corporate management. For basis of the Ukrainian corporate case frame insider is taken and outsider's systems of corporate management. Will notice that the insider's systems are characterized such situation, when property is concentrated and hands of a few persons, which own the large stakes of corporate property. In this case a management comes true and by these (legal or physical) persons and a management is under their direct influence. The outsider's system are characterized joint-stock property that is nebulized enough and that is why influence on making decision largely depends on managers, application of different forms of intercept of control after a corporation.

4. CONCLUSION

Summarizing the results of researches will mark that a corporate management is the difficult phenomenon that it is expedient to examine both in wide and in a narrow value; from the point of view of the system, structural, institutional, dualistic, normative, economically-financial, administrative-organizational, legal, socio-economic approaches and other approaches. Principles of corporate management in Ukraine take into account international experience and also the specific that take into account the national features of corporate sphere of management include. As a result of research of descriptions of corporate custom controls a subject and an object and also basic objective of corporate management are distinguished in Ukraine. To the last, it is taken: issuers, investors or shareholders, management and workers of enterprise, state in the person of public and organs of local self-government, creditors, other interested persons authorities, what enterprises of corporate type involved in the process of functioning. Taking into account traffic of corporate laws regulation such subjects of corporate management are certain as: citizens-proprietors of corporate laws; proprietors and management of enterprise - issuer of corporate laws or their proprietor; public and non-state organs and others like that. The basic functions of corporate management - planning, organization, coordination, control and motivations that is considered from the point of view of management corporate laws are certain and also from the point of view of a corporation's management.

LITERATURE:

1. *The Code of Ukraine. Commercial code of Ukraine, 16.01.2003, 436 – IV*, available online: <http://zakon2.rada.gov.ua/laws/show/436-15>
2. *The internal revenue code of Ukraine (Lists of Supreme Soviet of Ukraine), 2011, 13-14, 15-16, 17, 112) The Code of Ukraine, Law, Code, 02.12.2010, 2755 - VI*, available online: <http://zakon0.rada.gov.ua/laws/show/2755-17>

3. *The Law of Ukraine. On the joint-stock companies (Lists of Supreme Soviet of Ukraine), 2008, № 50-51, cm.384) from 17.09.2008 № 514 – VI*, available online: <http://zakon2.rada.gov.ua/laws/show/514-17>
4. Berle A. *The Modern Corporation and Private Property*, New York: Macmillan, (1932), — 418 p.
5. Coase R. *The Nature of the Firm*, Economic, (1937), 4, — p.p. 386–405.
6. Michael Cole Jensen. *Theory of firm: behavior of managers, agent expenses and structure of property*, Announcer of the Saint Petersburg university. Series are Management, (2004), p. 4.
7. Drucker P. F. *Concept of the corporation*, New York: John Day Co., (1972), 319 p.
8. Colin Mayer. *In search of the best director. A corporate management is in the transitional and market economies*, Kyiv, The Basis, (1996), 189 p.
9. *Materials of seminar are "Project of corporate management to Ukraine". The 1Th theme "Essence and principles of corporate management"*, Kharkiv, IFC, (2000), 120 p.
10. Kozachenko A. , Voronkova A. , Korenev A. *Corporate government bases: Studies. manual* , Luhansk: VNU, (2001), 480 p.
11. Gubuna E. *The management and corporate control are in a joint-stock company: Practical will relieve*, Moscow, Lawyer, (1999), 248 p.
12. Kashanina T. *Corporate law: Textbook for institutions of higher learning*, Moscow, NORMA-INFRA-M, (1999), 815 p.
13. Povazniy A. *Transformation processes of corporate management*, NAN of Ukraine, Donetsk, (2001), 290 p.
14. Rumyanzev S. *Ukrainian corporate case frame: becoming and development*, Kyiv, Knowledge, (2003), 150 p.
15. Nestor S. *The Corporate management and role of organization of economic collaboration and development*, Bulletin from a corporate management. The informative announcer of project MFC "The Corporate management in Ukraine", (2000), 9, p.p. 10-13.

RESEARCHING THE VIEWS OF STUDENTS AT THE UNIVERSITY NORTH

Anica Hunjet

*University North, Croatia
anica.hunjet@unin.hr*

Goran Kozina

*University North, Croatia
goran.kozina@unin.hr*

Damira Djukec

*University North, Croatia
damira.djukec@unin.hr*

ABSTRACT

*University North is a public institution that conducts activities of higher education, organising and conducting professional studies in university undergraduate, graduate and post-graduate studies and it also conducts scientific and development research. By studying students' opinions it wishes to improve the market recognition of the University, thus increasing the number of students that study at the „North“. Successful communication via social media today is almost no longer a question of choice, but has become one of the most important tools of modern business. Precisely because social networks are dynamic and available almost to anyone, they are an excellent example channel of everyday communication with the multitude of their users. In this paper a preliminary research of the opinions of the students at University North will be carried out. The data gathered in this research (survey questionnaire) will be processed by the method of descriptive and inferential statistics. For the purpose of testing the assumed hypotheses a one-way *t* test will be used.*

Keywords: *Higher education, Reserching, University North, Views of students*

1. ABOUT THE UNIVERSITY

University North is an institution of higher education whose founders are the towns of Koprivnica and Varaždin, in each town a university centre is located, and by Law on transfer of Founding rights from the towns to the Republic of Croatia it become the eighth public university in 2015. Today one the University's goals is to become an influential university and be known as a modern university, one that is oriented towards the needs of the local community, which implies the education of students in those skills that are necessary for the development of our community. After finishing their undergraduate studies students have the option of continuing their education at one of the offered graduate studies and thus enriching their knowledge. The quality of the studies is visible from the mission and vision, where the goals that we are trying to achieve are specified (Elaborat o osnivanju Sveučilišta Sjever, 2014). „The mission of the University North is to educate a capable expert cadre for the needs of the real economy and the health care system in the region of north-western Croatia through the quality execution of professional and graduate studies within the demands of the Bologna declaration. In carrying out this goal University North is organised as a dynamic organisation that constantly follows, applies and implements scientific and professional knowledge in modernising existing and developing new programs, promotes the concept of life-long education and deepens and maintains relations with the economy and cooperation with similar institutions of higher education, both in the country as well as abroad.“ From the mission, one can tell how it is the desire of the University that after their finished education students can be of benefit to

their local communities with the knowledge and skills they have acquired. „The vision of the University North is to be the leading, scientific, professional and socially responsible higher education institution for the education of cadres in the area of technical, economical, biomedical and healthcare, biotechnical and interdisciplinary sciences and the field of arts in north-western Croatia <https://www.unin.hr/o-sveucilistu/misija-i-vizija-sveucilista/> [pristupano: 29.04.2018.]. Graduates of University North are and will remain wanted and employable experts because of the high level and width of gained knowledge and competencies, ready for independent work in their profession. In its operation University North applies the principle of quality in high education, the principles of ethics, creativity, transparency, cooperation with other higher education institutions and above all good interpersonal relationships.“ The overall vision of the University North is focused on students. Not surprising, because the quality of study is measured precisely according to the students and their gained knowledge, which they can and do apply in practice (Statut Sveučilišta Sjever).

2. INFORMATION ABOUT THE STUDY PROGRAMS

University North offers a range of programs, in which everybody can find something for themselves. A rich choice of programs attracts people from different areas of interest. Study programs are carried out and organised on three education levels: undergraduate, graduate and post-graduate studies (Hunjet, Ostojić, Trbojević, 2010, p. 460). University North offers the possibility of education in two university centres- University centre Koprivnica and University centre Varaždin. Students get the possibility of enrolment in the undergraduate study by logging in the application on the site www.postani-student.hr and choosing the desired study course that is being taught at the University and a having passed State Matura. From the academic year 2018./2019. at the University centre Varaždin students can enrol in new undergraduate study programs: Mechatronics and Physiotherapy. New graduate studies are: Multimedia, Engineering, Construction and Nursing – management in nursing (nursing management).

Table number 1: Study programs that are being carried out at the University centre Varaždin

Type of Study	Course
Undergraduate study	Electrical engineering
	Multimedia, shaping and use
	Manufacturing engineering
	Construction
	Technical and Economical logistics
	Nursing
	Mechatronics
	Physiotherapy
Graduate study	Business economy
	Public relations
	Multimedia
	Engineering
	Construction
	Nursing- management in nursing (nursing management)
Postgraduate study	International economic relations and management

Source: <https://www.unin.hr/popis-studijskih-programa/> [accessed on: 29.04.2018.]

Also, new study programs were opened at the University centre Koprivnica. from the academic year 2018./2019. It is possible to sign up for new undergraduate studies: Nutritional technology

and Technical and Economic logistics, but also a postgraduate university study Media and Communication.

Table number 2: Study programs that are being carried out at University centre Koprivnica

Type of Study	Course
Undergraduate studies	Media design
	Journalism
	Operations and management
	Nutritional technology
	Technical and economical logistics
Graduate studies	Packaging
	Media design
	Journalism
	Sustainable mobility and logistics
Postgraduate study	Media and Communication

Source: <https://www.unin.hr/popis-studijskih-programa/> [accessed on: 29.04.2018.]

From these two tables it can be seen that the University puts significant effort in order to adapt their study programs to the labour market, that is to say to educate the deficient cadre and thus encourage the development of the overall economy in the north-western region, and it will continue to do so in the future (Horvat Novak, Hunjet, 2015, p 463).

3. THE EFFECTIVENESS OF HIGHER EDUCATION IN THE REPUBLIC OF CROATIA

The effectiveness of education can be defined as the output of a special review or analysis that is measured by the level of achieving special goals of education or the level on which the university fulfilled special goals. Measuring the success of a study programme or a university is carried out by means of various procedures that involve supervision, observation and a tour of the university. In order to get a primary measure of success it is necessary to collect important indicators, information and evidence that best depict the effectiveness of the institution in regards to the student learning and academic achievements. Measuring the effectiveness of education creates an additional value through the process of insuring quality and an accreditation procedure and contributes to the development of a culture of evidence in the university (Hunjet, 2009, p 251). The quality of higher education can be defined both in a broader and a narrower sense. In the broad sense quality represents the compatibility of higher education with the demands and needs of users, goals, norms and procedures (Hunjet, 2008, p 253). In the narrow sense quality represents the compatibility of processes and results of preparation of highly educated experts with the needs, goals, norms and standards of the state, employers and the society as a whole. The quality of higher education is the result of an influence of a large number of demands that are being imposed and imply the demands of users of higher education, the demands of the Bologna process and international norms, the demands of the system of quality management and the demands of business of a higher education institution (ZZDVO, 2003), (Zakon o osiguravanju kvalitete u znanosti i visokom obrazovanju). Indicators of success involve various activities of the institution, and the quality can be seen through the grade of study programmes and modules and the grading of the quality of participants that involves professors, students and the faculty as a whole. One can conclude that the quality of higher education is a complex term for whose creation, maintenance and development are responsible many elements such as the state, professors, students, employers and employees in higher education institutions (Hunjet, Kuhar, 2012, p 373).

4. ANALYSIS OF THE CURRENT CONDITION

University North, despite a large selection of programs, still does not attract a large number of students. There are plenty of reasons for that. The main reason is an inadequate awareness on the behalf of the public, that is to say the target group. As the need for education grows ever larger, as does the competition, that leads to a second equally important factor. Today price is an important factor when deciding about and choosing a higher education institution (Hunjet, Kozina, Milković, 2014, p 216). The University has about 3000 full and part time students from all over Croatia and the neighbouring countries, and it employs over 350 qualified employees and associates in all teaching, scientific-teaching and arts-teaching positions. The ration of professors and students is 1:23. The basic reason and goal of establishing University North is a long term increase of the number of high educated population in the counties it operates in, in other words in the north-western region of Croatia.

4.1. Marketing communication

Today, without advertising there is no success. For every new business it is important to invest sufficient means into advertising, and the same applies to institutions. The money invested into advertising will eventually pay itself off, if it is carried out properly. As everything is revolving around the Internet, people spend most of their time on a computer, it is important to advertise yourself on-line. Unfortunately, our University does not invest enough into promoting its numerous departments, and thus can't reach the competition, which is strong (Kesić, 2003, p. 363). University North has a main webpage online that can be visited by anyone interested. The page contains plenty of information about the university, as well as about its departments. Future students can see what awaits them and what courses they can take. Speaking of future students it would be useful to enable some form of communication with them, where their questions are met with a quick and efficient answer, thus attracting them to continue their education here. As social networks are growing in popularity and the young spend more time on them, as well as receiving most information there, a good step would be opening an active page on one such network, in order to come closer to the target group. A present Facebook page is active, but has no information that would interest younger people that are only now finishing high school. According to a survey carried out among high school children, data was gathered about the information they would like to see about every higher education institution. They are based on price of enrolment, the programme that is prevailing and the most important thing for them is to see the average score for individual courses. It is important to note that communication with present students is fine, but could be more advanced. As there are various applications for online studying, so does the University have an e-study, only it is a great shame it is not more used because in that way students could at any time receive feedback from the professors and from each other and thus be more satisfied. In that way they would have all the course material in one place as well as the curriculum of a certain professor, accurate information about exam dates and about any changes that may occur (Hunjet, A., Kozina, G., Đukec, D, 2018, p. 798). An important and good promotion for the University is the "open door days", carried out annually and in that contact is made with future students. No matter how good this type of promotion is there is no improvement if such an event is not promoted weeks in advance, through all available media that are accessible both to the young and elderly population.

4.2. Planning new activities

University North is planning on becoming the leading educational, scientific, professional and socially responsible institution for cadre education in the field of technical, economic, biomedical and healthcare, biotechnical and interdisciplinary sciences as well as the field of arts in north-western Croatia.

An important factor in the planning of future activities of the University we would like to point out is advertising via various gifts with the logo of our University. Firstly, that would be cups that have the University logo on them so that anyone who sees the cup would notice something new and interesting and would be intrigued about it. Also we would hand out free pens. Besides the logo the cups and the pens must have the web address of the University on them, so that anyone interested could reach information about the University in the quickest way possible. Planners are also one of the ideas how to advertise the University. Small planners with the University logo on them, in which we can jot down various notes and in that way they can always be in our bags are also an appropriate gift and a way of advertising.



Picture 1: Cups with the University logo



Picture 2: Planners with the University logo

5. MEDIA PART

Media are the most important means of advertising in the 21st century. Every day we can see a multitude of commercials whether they are on the television, on the Internet or in the newspapers. Because of these commercials we often become interested in a certain item and we wish to acquire or purchase it. Advertising via media is the best way of advertising because the media is accessible to a large majority of people. Media advertising is important for every business and that includes University North. Via media we familiarise the University to the people and show of its qualities. It is necessary to promote and advertise the University so that people hear about it all over the country and abroad and so that as many people as possible enrol into offered programs. As the main goal of our project is to familiarise people all over the region with University North promotion is one of the key factors.

The main promotion, that is to say the advertising, must be carried out via television, social networks and newspapers because the large majority of people follow said media on a daily basis. Social networks and the Internet are followed on a daily basis by a large number of young people, therefore it is important to interest them and encourage them to think about enrolling into University North. For these reasons a large part of the advertising would be carried out via the internet.

5.1. Media mix

As the most important media we single out:

1. Internet
2. Television
3. Radio

So that the younger population would get the necessary information about the study programs, for the purpose of promotion the internet is used, a necessary source of information for the youth in modern times. Promotion via television and radio is aimed at the older part of the public, those that follow a lot of information via these media. As often employed people do not have plenty of free time for independent researching this way of promoting is the most effective in reaching them. The goal of new ways of promoting is to reach a more competitive position on the market. It would be apparent through familiarising an ever larger number of people, both future students and the public at large with University North. It is important to monitor changes on a weekly basis, to notice possible errors or a wrong way of promoting and to correct it if need be. Weekly analysis would be carried out via graphic displays of visitation of University's internet pages, and by number of asked questions to the future students on a portal where that is possible. The effectiveness that would be achieved by these actions can be monitored for several months, even years. In this case a period of 12-24 months is implied. The following can be efficiently done via various surveys and a measurement of public interest after all the activities are carried out. After the results are gained the previous state must be compared to the present one, and in case of positive shifts it is important to carefully plan out future promotion and advertising of the University in order to maintain and in time possibly improve the results. Of course, this is not possible to achieve over night, but dedication and the quality of promotion is important and cannot be underestimated.

6. EMPIRICAL RESEARCH OF ATTITUDES OF STUDENTS OF UNIVERSITY NORTH

In this chapter empirical research of student attitudes about University North is described. Research questions and hypotheses are set, following by the description of data and methodology of the study. In final part of this chapter results are presented and conclusions are derived (Field, A. 2013).

6.1. Research questions and hypotheses

Main goal set by the authors of this paper is to research student attitudes about University North. This paper is a result of effort to address the following questions:

1. Are student expectations fulfilled?
2. Are students content with knowledge gained during their study?
3. What are the student attitudes towards the name and visual identity of the University?

Four main hypothesis are set:

H1: Studying at University North fulfils student expectations

H2: Students are content with knowledge gained during their study

H3: Students of University North evaluate the name of the University positive

H4: Students of University North evaluate the visual identity of the University positive

6.2. Research methods and data

Data used in the research were gathered in online survey. Total of 619 students answered questions about their attitudes. Students were asked to evaluate if their expectations were fulfilled and if they are content with knowledge they gained at the University. Also, they were asked about their attitude about the name and visual identity of the University. In table 3 descriptive statistics for questions described above are shown. We can see number of observations, mean, standard deviations and standard error for mean. Mean values for all questions are between 3,45 and 4,22 with standard deviations ranging from 0,951 to 1,089, which means that values are centralized around mean value. To confirm the hypotheses set by the authors, one sample t – test was conducted. Data was analysed using statistical software SPSS.

Table 3: Descriptive statistics

	N	Minimum	Maximum	Mean	Std. Deviation
Studying at University North fulfils student expectations	610	1	5	3,56	,951
Students are content with knowledge gained during their study	609	1	5	3,45	1,089
Students of University North evaluate the name of the University positive	614	1	5	4,22	1,063
Students of University North evaluate the visual identity of the University positive	598	1	5	3,88	1,051
Valid N (listwise)	591				

Source: output of SPSS

6.3. Results and discussion

In order to research their attitude, students of University North were asked to evaluate four statements. The attitudes about a certain statement were measured with the Likert scale ranging from 1 (strongly disagree) to 5 (strongly agree). The results are summarized in table 4 and in Figures below.

Table following on the next page

Table 4: Attitudes of students of University North

		%
Studying at University North fulfils student expectations	I strongly disagree	2,6
	I disagree	10,2
	I don't agree nor disagree	31,0
	I agree	41,5
	I strongly agree	14,8
Students are content with knowledge gained during their study	I strongly disagree	6,6
	I disagree	10,2
	I don't agree nor disagree	31,7
	I agree	34,6
	I strongly agree	16,9
Students of University North evaluate the name of the University positive	I strongly disagree	3,4
	I disagree	5,7
	I don't agree nor disagree	10,3
	I agree	27,0
	I strongly agree	53,6
Students of University North evaluate the visual identity of the University positive	I strongly disagree	4,2
	I disagree	4,5
	I don't agree nor disagree	23,2
	I agree	35,3
	I strongly agree	32,8

Source: output of SPSS

In Figure 1. the evaluation of statement about fulfilment of student expectations is shown. As we can see more than 56% of the participants of the study agrees or strongly agrees with the statement that studying at University North fulfils their expectations.

Figure following on the next page

Figure 1. Studying at University North fulfils student expectations

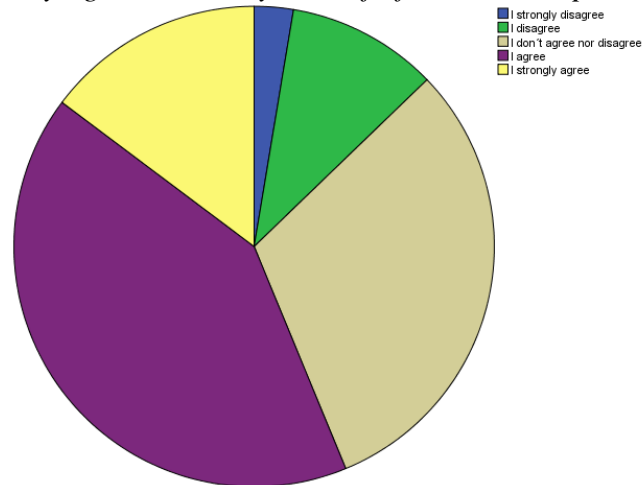

Source: output of SPSS

In Figure 2. the evaluation of statement about contentment with knowledge gained during the study is shown. As we can see more than 51% of the participants of the study agrees or strongly agrees with the statement that they are content with knowledge gained during the study.

Figure 2. Students are content with knowledge gained during their study

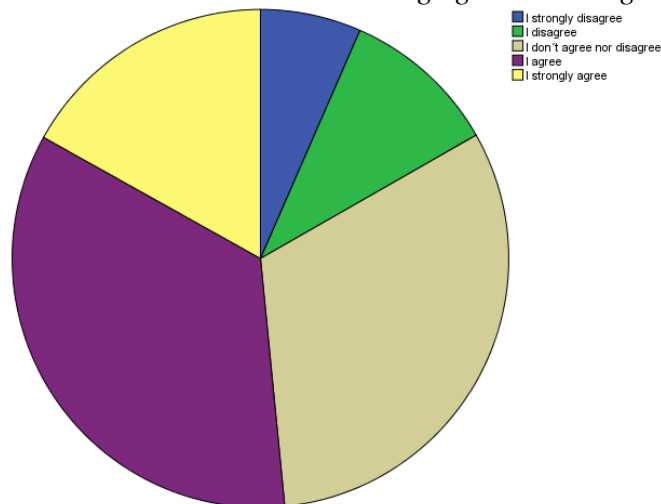

Source: output of SPSS

In Figure 3. the evaluation of the name of the University is shown. As we can see 80,6 % of the participants of the study agrees or strongly agrees with the statement about the name of the University. Clearly, students think very high of the name University North.

Figure following on the next page

Figure 3. Students of University North evaluate the name of the University positive

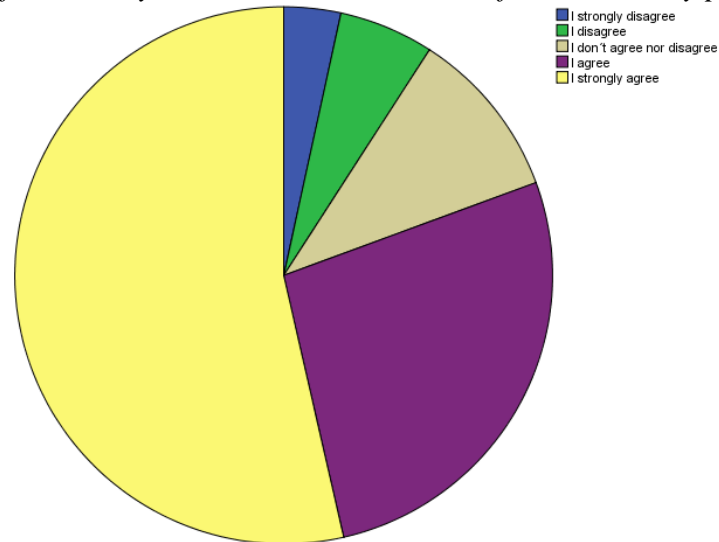

Source: output of SPSS

In Figure 4. the evaluation of visual identity of the University is shown. As we can almost 70 % of the participants of the study agrees or strongly agrees with the visual identity of the University North.

Figure 4. Students of University North evaluate the visual identity of the University positive

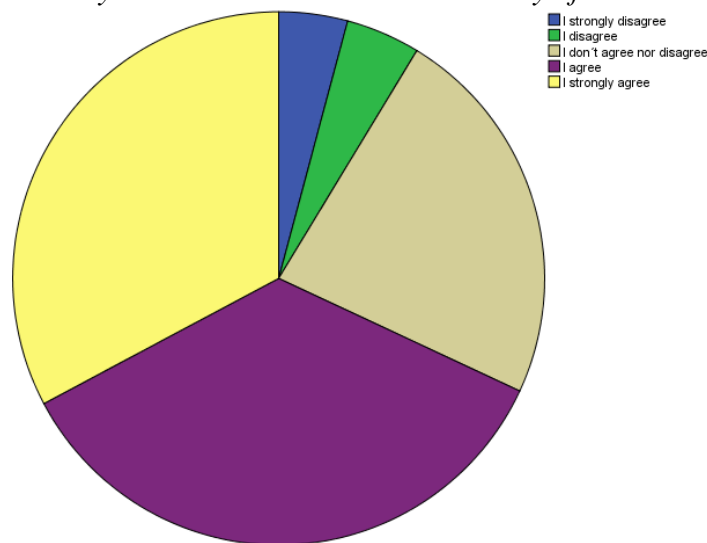

Source: output of SPSS

To test the hypotheses, we made in this paper, we conducted one sample t – test. For every statement that we test we made two assumptions:

$$H_0: \mu \leq 3$$

$$H_1: \mu > 3$$

The sample has a statistically significant higher mean than 3 ($p < .05$) and, therefore, we can reject the null hypothesis and accept the alternative hypothesis. Thus, the results of the test (table 5) indicate that students evaluates all four statements with agree or strongly agree. Based on the one sample t – test we can conclude that student expectations are fulfilled. Further, students are content with the knowledge they gain during their study. Also, they have a positive attitude towards the name and visual identity of the university. The hypotheses that we set in this paper are confirmed.

Table 5: One – Sample Test

	Test Value = 3					
	t	df	Sig. (2-tailed)	Mean Difference	95% Confidence Interval of the Difference	
					Lower	Upper
Studying at University North fulfils student expectations	14,435	609	,000	,556	,48	,63
Students are content with knowledge gained during their study	10,234	608	,000	,452	,36	,54
Students of University North evaluate the name of the University positive	28,370	613	,000	1,217	1,13	1,30
Students of University North evaluate the visual identity of the University positive	20,468	597	,000	,880	,80	,96

Source: output of SPSS

7. CONCLUSION

The goal of the communication strategy of University North is to encourage and create a need to enrol into undergraduate, graduate and postgraduate studies. By hard work and continuous investment into the quality of studying and by improving its own staff University North will become one of the best universities in this part of Europe. When enrolling students in undergraduate and graduate studies a questionnaire will be carried out in order to find out how did the students became aware of University North. Was it via the media and if yes, via which one? Or was it at direct lectures at school? How interesting and useful do they consider the official University sites etc. On the basis of the questionnaire results marketing activities in the following years will be carried out. In this paper an empirical research of the opinions of the students at University North was carried out. Via a survey questionnaire the opinions of the students regarding the quality of studying and the University's visual identity were researched. The research was carried out with the goal of further improving the quality and identity of the University. Research results show a high degree of satisfaction among the students with the present state of things. From the aforementioned it can be concluded that the University is on the right path of fulfilling out its goals of creating a recognisable institution of higher education that will form the foundation of future economic and social development.

LITERATURE:

1. Field, A. (2013). *Discovering statistics using SPSS*, Sage Publications
2. Horvat Novak, D.; Hunjet, A. (2015). Efficiency analysis of higher education in Croatia.// TEHNIČKI GLASNIK, TECHNICAL JOURNAL, Znanstveno-stručni časopis Sveučilišta Sjever, Scientific professional journal of University North. 9, 4; 461-468, ISSN 1846-6168 (Print), ISSN 1848-5588 (Online)
3. Hunjet, A., Kozina, G., Milković, M.: POLICENTRIČNI RAZVOJ ZNANOSTI I VISOKOG OBRAZOVANJA -OSNIVANJE SVEUČILIŠTA SJEVER // Proceedings, 4th International conference "VALLIS AUREA2 FOCUS ON: REGIONAL&INNOVATION DEVELOPMENT / Branko Katalinic (ur.). Požega, Vienna : Polytechnic in Požega, Croatia&DAAAM Interantional Vienna, Austria, 2014. 215-223

4. Hunjet, A., Kozina, G.: Upravljanje znanjem i mogući rizici // Dani kriznog upravljanja, Zbornik radova, 7. Međunarodne znanstveno-stručne konferencije / Veleučilište Velika Gorica (ur.). Velika Gorica : Veleučilište Velika Gorica, 2014. 413-426
5. Hunjet, A. & Kuhar, M. (2012). Development of Quality Assurance System in Croatian Higher Education System. Proceedings of the 3rd International Conference „Vallis Aurea“ Focus on: Regional Development, 371-379, ISSN 1847-8204,, ISBN 978-953-7744-16-8, ISBN 978-3-901509-78-0
6. Hunjet, A. Ostojić, G., Trbojević, G. (2010). Stručni studiji i decentralizacija visokog obrazovanja u Republici Hrvatskoj. Proceedings of the 2nd International Conference „Vallis Aurea“ Focus on: Regional Development, 459-465 ISBN 978-953-7744-06-9, ISBN 978-3-901509-76-6
7. Hunjet, A. (2008). Osiguranje kvalitete u hrvatskom visokoobrazovnom sustavu. Zbornik radova 1. znanstveno-stručno savjetovanje Tekstilna znanost i gospodarstvo, Tekstilno-tehnološki fakultet Sveučilišta u Zagrebu, Zagreb, Hrvatska; 253-256, ISBN 978-953-7105-23-5
8. Hunjet, A. Uloga zapošljavanja - poveznica gospodarstva i znanosti // 2. znanstveno-stručno savjetovanje Tekstilna znanost i gospodarstvo / Ujević, Darko ; Penava, Željko (ur.).Zagreb : Sveučilište u Zagrebu, Tekstilno-tehnološki fakultet, 2009. 251-254
9. Hunjet, A., Ostojić, G., Trbojević, G. (2008). Vrednovanje visokih učilišta sukladno Zakonu o znanstvenoj djelatnosti i visokom obrazovanju, Zbornik Visoke poslovne škole Libertas, Zagreb, 1., 409-413, ISSN 1846-9728
10. Elaborat o osnivanju Sveučilišta Sjever, 2014
11. Zakon o osiguravanju kvalitete u znanosti i visokom obrazovanju, NN 45/09
12. Zakon o znanstvenoj djelatnosti i visokom obrazovanju, NN 123/03, 198/03, 105/04, 174/04, 02/07, 46/07, 45/09, 63/11, 94/13, 139/13, 101/14, 60/15, 131/17
13. <https://www.unin.hr/o-sveucilistu/misija-i-vizija-sveucilista/> [pristupano: 29.04.2018.]
14. <https://www.unin.hr/popis-studijskih-programa/> [accessed on: 29.04.2018.]
15. Kesić T. (2003) *Integrirana marketinška komunikacija*. Zagreb: Opinio
16. Hunjet, A., Kozina, G., Đukec, D. Distinctiveness and quality of University North on the higher education market in the Republic of Croatia // *Economic and Social Development (Book of Proceedings), 27th International Scientific Conference on Economic and Social Development / Bozina Beros, Marta ; Recker, Nicholas ; Kozina, Melita (ur.).*Varaždin : Varaždin Development and Entrepreneurship Agency, Varaždin, Croatia Faculty of Management University of Warsaw, Warsaw, Poland University North, Koprivnica, Croatia, 2018. 790-803

FACEBOOK AS A PLATFORM IN PROMOTING CONTINENTAL TOURISM

Zeljka Zavisic

*Zagreb School of Business, Croatia
zeljka.zavisic@pvzg.hr*

Senka Zavisic

*Polytechnic Lavoslav Ružička Vukovar, Croatia
senkaza@gmail.com*

Neven Sipic

*Zagreb School of Business, Croatia
neven.sipic@pvzg.hr*

ABSTRACT

The aim of this paper is to investigate whether the subjects of continental tourism in the Republic of Croatia use the advantages of planning advertising and promotion through social networks, with special emphasis on Facebook as the most prominent social network in Croatia. For the purpose of research, a questionnaire has been created that contains questions about exploiting the potential of promotion and advertising offered by social networks, as well as the share of such advertising in relation to other promotional methods. The survey was conducted on a sample of 87 business entities that are classified as subjects of continental tourism and present the market situation in the Republic of Croatia at the end of 2017. The purpose of this research was to cover insufficiently researched area of advertising of continental tourism entities through social networks, as a modern communication channel, with an emphasis on Facebook. The expected scientific contribution is in the exact determination of the existing situation, and the reference to the advantages of this kind of advertising and promotion. The results of the research showed that the subjects of continental tourism have not yet fully understood the importance as well as the advantages offered by social networks. In a satisfactory percentage, they have started to engage in social networks, but there is still a lack of round activity and understanding of all possibilities of this kind of promotion. The data obtained can be used for the purpose of providing better marketing positioning of subjects in continental tourism of the Republic of Croatia.

Keywords: *continental tourism, Facebook, promotion, social networks*

1. INTRODUCTION

Nowadays, social networks present a strong marketing tool. Therefore, it is vital to know how to utilize their strength in order to improve business activities. Boyd and Elisson (2007) define social networks as a web-based service that enables individuals to create public and semi-public profiles within an enclosed system, articulate the list of other users with whom the network is shared and use their own connection list and other connection lists within the system. Even though the initial purpose of social networks was to satisfy personal needs for communication and information; vast number of users, free content, global outspread, as well as other social media specifics made them a perfect tool for companies to communicate with clients. Nowadays, they are a source of numerous business ideas, an opportunity for business promotion, as they represent a place where trends in business that characterize today's global market are created (Kovač, 2014). Social networks allow successful business activities because they offer better connectivity and openness towards consumers, advertising to target groups, branding, finding potential partners, developing new ideas and better placement on search

engines that guarantee business success. Such a media, backed with online technologies, offers a direct access to various statistics, while there is no alternative media for determining target population and tracking results of a campaign and its success rate. Marketing communication on social media is a method of Internet marketing, with the use of multidisciplinary marketing campaign, that approaches social media users and transmits a message that usually calls for action, and less often only provides information. Just because of that, social networks are becoming platforms for successful and productive business processes. Moreover, a question of possible exploitation of such niche market promotion, like continental tourism market in Croatia, arises. The research that follows aimed at better understanding what implications such technologies and trends in marketing have on subjects in continental tourism, and the goal was to research if the subjects use planned advertising and promotion on social networks, with the main emphasis on Facebook, as the most popular social network in Croatia.

2. LITERATURE REVIEW

Several researchers have studied the role of social networks in marketing. For example, Iyengar, Van den Bulte, and Valente (2011) have focused on influential users in viral marketing, and Du and Kamakura (2011) have modeled contagion in product diffusion. There has been little emphasis, however, on the active management of customer networks and on testing the effects of network activities and structure on business outcomes. Firms or individuals can use a variety of networking activities to stimulate network growth and online success. (Ansari et al., 2018). According to Nickson (2014), social networks that were rising exponentially in the last few years will continue to be extremely important for hotel industry, and the reflection of their use a display of business direction towards future and increasing the level of competitiveness. The process of planning based on which a communication strategy can be projected and which will be applied in making a theoretical model of communication strategy on social networks, according to Li and Bernhoffu (2010) is called POST, which is short for people, objectives, strategy and technology. It includes directions for an adequate choice of target audience, defining goals and an appropriate strategy for achieving them and using possibilities the technology offers, in this case social networks. Tourism market is constantly changing, which is why companies needed to adjust their product and services strategy in accordance with different levels of market application, with a purpose of successfully managing the changing needs of consumers and competition's offer. Many changes are expected on a tourism market, and they relate to a massive development expansion and stiffer global competition that will create a situation where destinations and hotels need to be very creative and distinguish themselves in a conception, as well as access to the market, distribution and experiences they offer (Viet Hung, Zhuochuan, 2011). From the public relations viewpoint, every company, government institution or non-government organization becomes a media that can directly communicate with its audiences. Social networks are especially important in the field of public relations because they advance communication, affect social changes, and lead to a development of new communication dimensions, especially in business communication (Demetterffy-Lančić, 2010). The affordances, popularity and pervasive use of social media platforms such as Facebook, Twitter and Instagram have made these platforms attractive to organizations for enhancing their competitiveness and creating business value. Despite this apparent significance of social media for businesses, they are struggling with the development of a social media strategy as well as understanding the implications of social media on practices within their organizations (Kwayu et al., 2018).

3. MARKETING COMMUNICATION ON SOCIAL MEDIA

Advantages of planned advertising on social media are numerous. Advertising within social networks offers more opportunities, as well as a fast insight in specific company's results, while

some aspects of such advertising are completely free. In the context of digital advertising, it is clear that Croatian market increasingly follows European market, as well as global trends. Larger and more serious B2C companies in Croatia are using digital technology in their marketing efforts. As it is becoming a trendy advertising method, bigger portions of companies' budgets are invested in web advertising and content production. More than ever, brands and marketing experts have to get along with the latest trends and technical achievements in order to stay focused. All the before mentioned supports a thesis that we find ourselves in times of increasing direct marketing where target market is not a part of massive market, but a chain of individuals with whom one can communicate directly. Users are sometime buyers and sellers at the same time, even creators of communities with its amenities (Ružić, Biloš and Turkalj, 2014). Marketing on social media can be defined as a strategic approach aimed at inciting potential customers on a voluntary exchange of information about a product or a service and commenting it, which contributes to a higher level of promotional message exposure. Addressing target markets or communicating with them has changed with the invention of social networks and their growth. Marketing programs are transformed and directed to become a subject of voluntary exchange between large number of users on social media. Advantages of marketing on social media are the speed of communication and user feedback (Kesić, 2003). Facebook has a clear and unique advertising strategy. While Google, an undisputed king of Internet advertising, helped people to find what they have decided to buy, Facebook will help them decide what to buy. When a person searches something on Google, an advertisement displays as a reaction to what is written in a search engine. Usually users decide to purchase based on such advertisements, which in return brings billions of dollars to Google. However, the advertisements users tend to click are for products and services that are already calculated as a necessity. In marketing, Google AdWords satisfies demand, while Facebook creates demand (Kickpatrick, 2012). Facebook is the most popular network for tourism and hotel industry due to the biggest number of users (Zavišić, Luburić, 2013). It is a network where almost all tourism subjects have an opened profile or a group through which they communicate with their loyal or potential clients. Among standard comment possibilities, posting different content, etc., Facebook offers the biggest number of communication possibilities for its users; for example, some hotels offer the possibility of creating a direct accommodation reservation through Facebook profile.

4. RESEARCH METHODOLOGY

For the purpose of research, a survey with three groups of questions was created. Questions relate to the utilization of promotion potential and advertising offered by social networks, as well as a share of such advertising when compared to other ways of promotion. The research was conducted on a sample of 87 businesses across Croatia classified as subjects of continental tourism that belong to the following regions: Zagreb and its surroundings, northwest Croatia, east Croatia and mountain Croatia. Data collection and analysis from social networks will be done with the use of social network analysis software (Mediatoolkit and Sentimeter), while some data will be analysed in SPSS and shown in graphs. A survey was introduced to people in charge of managing social networks in order to get a full access to the communication strategy on social networks. Questions analyzed if the communication goals, target market, communication tools and budgets are defined in advance and examined if the communications action plan results are followed (if such exist). Moreover, the intention was to find whether the continental tourism subjects use paid advertising and how satisfied they are with campaign results. 87 surveys were analyzed, out of a total number of 150 sent questionnaires. Methods of descriptive and inferential statistics were used in data analysis. In addition, a Chi-squared test was performed for hypothesis testing, in order to test the relationship of chosen characteristics.

A questionnaire contained 13 close-ended questions. Research results show current situation in continental tourism market in the late 2017., while the expected scientific contribution is in ascertaining the current state. The main hypothesis H1 is: Social networks can contribute towards developing business activities to subjects in continental tourism, while auxiliary hypothesis is: The most represented social network whose full communication potential use for continental tourism is Facebook.

5. RESULTS

The results of this research, methodologically explained in the previous chapter, are shown chronologically based on the answers in the survey, and are statistically discussed. The main presentation of continental subjects on social media is a personal introduction to potential users. Personalizing the business subject's page is important because it emphasizes on subject over the other. By making adjusted pages for social networks a direct effect on interaction with consumers occurs during which a notion on recognizing business subjects strengthens. Also, skilled communication with fans can results in a greater number of fans for the brand through „word-of-moth“ effect, making fans gain more trust in the brand. The results confirm that the subjects of continental tourism have recognized the before-mentioned, whereas 77% of respondents uses social networks for promotion. Since it is clear that most of the questioned continental subjects use social networks for advertising (Facebook 78.6%), listed hereafter will be the key steps for successful advertising and promotion and the results of using those tools for the purpose of advertising continental tourism subjects.

Social network advertising frequency	Arithmetic mean	Median	Mode	St. Dev.	Coef. Of Variation
	2,35	2,00	2,00	0,71	30,16

Table 1: Chosen descriptive statistic ratios related to using social networks for advertising

Even though there are opposing views on using the arithmetic mean, and indicators based on it, in the case of variables measured on Likert scale, we used them in the analysis order to make choosing easier. According to median, half of respondents rated the frequency of using social network advertising with a grade 2 or lower, while the other half with a grade 2 or higher. Mode also had number 2 as value. So, most of the respondents stated they use social network advertising occasionally. Standard deviations and coefficients of variation indicate that variability level of answers on both questions can be considered small.

5.1. Creating a profile

Facebook users are offered an option of creating Facebook profile, FB Group and FB Fan Page, i.e. professional page.

- Facebook profile – individuals create it for their personal, social, and other reasons. One can connect to 5 000 friends even though very few people know that many. However, due to a number of individuals on a network, promotion effects can be surprising. Almost 33% presents their services through FB profile, that is mainly aimed at individuals due to a limited number of followers, i.e. friends. It is also inadequate for promotion since all the personal friend dana of that subject are visible to people that maintain the business subject s profile, whose names are usually not known.
- Fan page – one of the most useful Facebook tools intended for marketing. The main advantage of fan page is visibility in „news feed“, why it is important what is posted on the page. It is important not to overdo with promotion „pressures“ and the promotion rate. The

results show that respondents mostly use Fan pages (50%) for promotion, which is also the best form for promotion.

- Facebook group - is a place of assembly over some idea or phrase. The advantage is such that massive calls for joining can be sent. Facebook group is one of the inferior tools due to a number of deficiencies in effectiveness. The main drawback is that the post is not shown on „news feed“. 27% of respondents use FB group to promote their services, but due to its deficiency, there is a chance that group members do not see posts on time which results in a interaction reduction, which is not good for this type of promotion.

It is also important to note that Fan pages offer advertising possibilities, i.e. creating Facebook Adds that can be aimed at specific audience, which really intensifies page visibility on Facebook and can have a significant role in attracting new fans.

5.2. Insuring branding

The first step when opening a page would be filling the profile information and placing branded logo as a profile photo. In that way, new visitors are given a know start point. Results show profile photo is completely aligned with business identity in 61.2% cases, while only 38.9% of respondents have partially aligned photo. Moreover, if a specific service or a product is promoted, a photo aligned with that can be places as profile photo. However, it needs to be actual only for the duration of a promotion, that is, while the offer lasts. For even stronger brand experience, Facebook let one create different applications that are thematically and visually adjusted to a brand. By making these adjusted applications for social networks, it is easy to directly affect on interaction with customers during which brand awareness increases. This possibility is still not sufficiently recognized by users, since only 23,5% users have a created application.

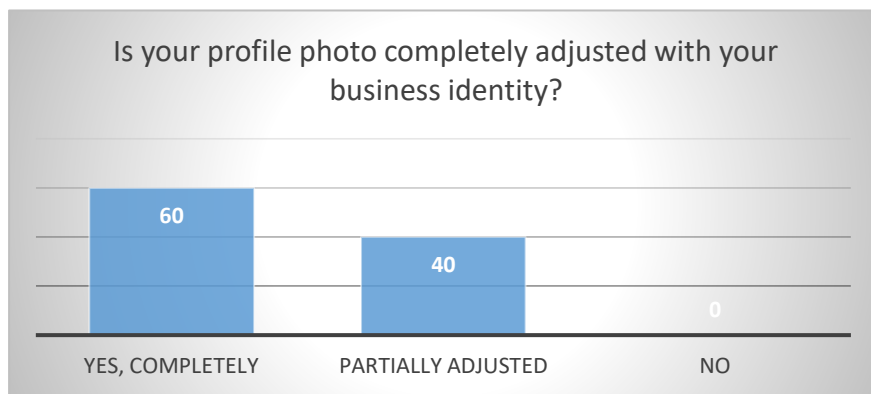

Chart 1: Compliance profile photo with business identity

5.3. Monitoring the event flow and participation in a dialogue

Connecting with fans through two-way dialogue is important because Facebook users got used to a certain way of behavior. Two-way conversation encourages interaction, trust and information spread. The best way for such communication is oftentimes participation in a debate and creating their own, and when fans comment something, take their comment in consideration and respond. It is important to bear in mind that every dialogue with fans is visible and available to all of his friends on Facebook. In order for all comments not to end up on the main page, it is necessary to have a place for discussion. Giveaways (used by 20% of respondents) are also a great way to promote products and services. Giveaways can especially have good results if they are attractive, and participation easy. Facebook users interact, and every organization should join that interaction. A brand s fan page should be a fertile ground for an equal interaction, so fans should be encouraged to communicate.

It can be achieved by opening discussions on their own web page and taking an active part in them by answering questions. It is important to remember that such types of discussions should be monitored in „real-time“, which means it is necessary to have a person responsible for managing social media, about which more will be written in the next part of the paper. Even though communication is key for success on social media, the results indicate it is not yet fully adequate to achieve a satisfactory success in promotion. It is important to mention the term community management- a term usually associated with marketing on social media. It relates to managing and maintaining business profiles on social media with an intent to keep the clients, broaden the business and generally promote the brand and its services. The role of community manager is to be engaged in the process of promotion by searching for information and listening to feedback, finding interesting discussion topics, creating promotion campaigns, answering on user questions, and generally giving a dose of personality to a brand and its products or services. It is also important for business subjects that are present on social media, to have a community manager for their page to be updated on time and with right content, which further results will show. In the largest percentage (75%), the FB site is managed by a person of interest related PR, but such a person is insufficiently acquainted with social networking rules and it is best to have PR specialists in charge of social network management - community managers. 12% of respondents have recognized this pre-eminence and have an employee community manager, while 13% use PR / marketing agencies for this purpose, which is certainly a better option than the first, but effective public relations is not just external communication but also internal communication where PR agency is not so significant. From the above it is apparent that the best solution for effective communication is certainly a PR expert - community manager.

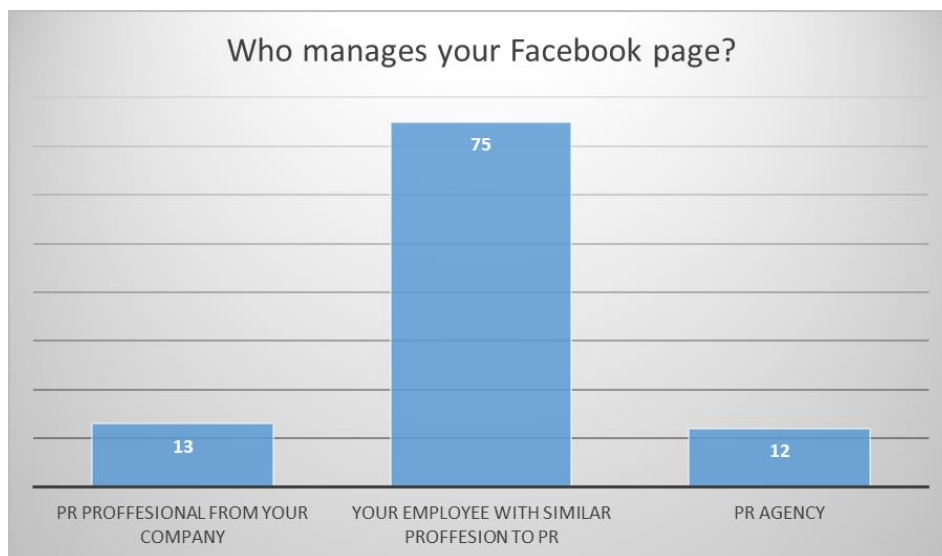

Chart 2: Facebook page management

The research results show that respondents update their websites fewer than once a month (47.7%), while absolutely nobody does it on a daily base. It is simply unacceptable for such a media, nor can it lead to success. As already states, social media are platforms where the exchange of information happens in a real time, and if there is no interaction with a target market for a month, the presence loses its meaning, especially promotion. It is best to update the page on daily basis and keep interaction with target market, but it is also acceptable to do it on a weekly basis, which 14.3% of respondents does, conditioning that they answer clients inquiries/comments. The role of a community manager is vital in order to use all the potential social media offers and due to the need for constant presence.

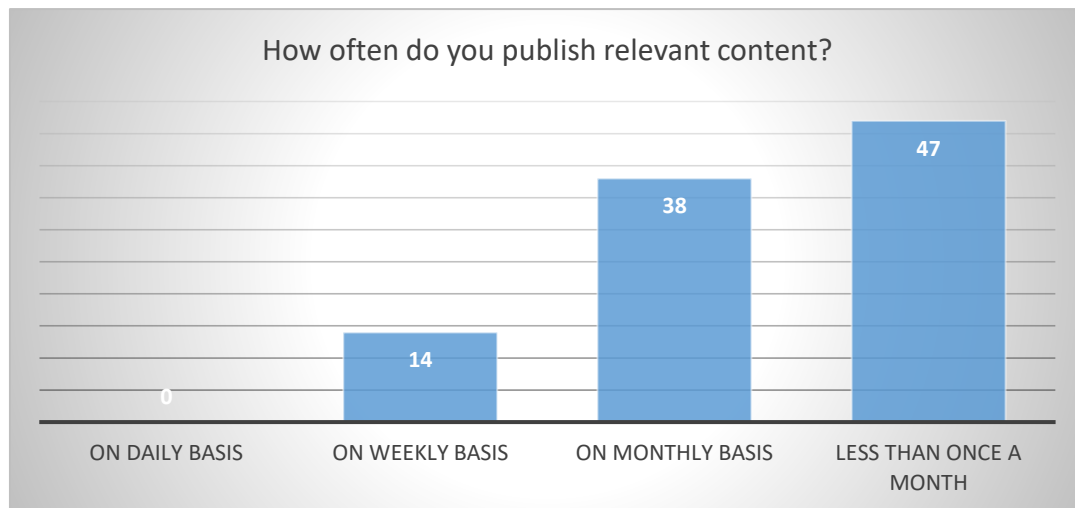

Chart 3: Frequency of publication of relevant content

Video content production is exponentially growing due to low cost of production, wider availability of such content through social media. The video has double advantage. Firstly, it is easier to approach the customer by using it, and secondly, it is easier for users to transmit their message with a „under one minute“ video. That is why Facebook introduced video as a means of promotion (Zavišić and Mijatović, 2016.) Sharing promotional video materials and creating short commercials which show the effectiveness of services and products is becoming a mandatory part of promotional campaign on social networks, however, it is still not recognized by business subjects in the continental tourism.

5.4. Facebook advertising

Facebook advertising is very successful because of private data that users leave on their pages. Facebook enables advertisements to be targeted based on location, age, sex, relationship status, interests, keywords, workplace, etc. Also, Facebook marketing directly ensures more visits to business subjects web page, and more visits translate to more profits. Such interactive advertisements soon replaced sponsored notifications which were, until then, the main advertisement on Facebook. Sponsored stories, are not, as Zuckerberg¹ says, „information that people produce on a website“. This new type of advertisement became a big hit. Moreover, once advertiser creates a connection with a user, he/she gets what Facebook calls „derived value“. That is, according to experts, after the brand gets connected with the consumer, around two hundred additional free „display“ of information on that brand among Facebook users will arrive (Kickpatrick, 2012). Based on result parameters related to Facebook advertising, it is concluded that almost 3/5 (60%) of respondents did not use Facebook advertising campaigns, while 2/5 of surveyed that used campaigns, only 50% did it once. When discussing about the success of promotion through such a marketing channel, a cumulative result, in terms of an evaluation grade (1- the worst grade, 5- the best grade) is 3.5, that is, 80% of respondents who used Facebook advertising campaign was satisfied with the campaign results (partially, mostly or completely satisfied). In viewing further justification of such campaigns, 75% of those who used Facebook advertising campaign plan on repeating it again. Social networks can contribute towards developing business activities to subjects in continental tourism, while auxiliary hypothesis is: The most represented social network whose full communication potential use for continental tourism is Facebook. Since the p value is 0.069, which is more then 0.05, with 95% confidence level, we can conclude that there is no statistically significant difference between the two hypothesis, and both are accepted.

¹ Zuckerberg, Mark – founder and CEO of Facebook

Pearson's Chi-squared test
X-squared = 14.127, df = 4, p-value = 0.069

Table 2: Chi-squared test

6. CONCLUSION

Quality communication, presence and interaction with users on social networks will, in long-term, bring great results and customer relations that need to be constantly nurtured. The benefits of presence on social media are numerous, from strengthening brand awareness to successfully launching new products, which ultimately increases sales. From all the before mentioned, it is evident that the presence of business subjects on social media is becoming more and more mandatory. But, it is a matter of knowledge and experience if companies will manage in a virtual world of social networks and maximally use all of their advantages. Continental tourism business subject analysis in Croatia shows that the respondents did not understand the importance and advantages associated with social media. They are becoming present on social media in a satisfactory percentage, but what lacks are well rounded actions and understanding all of the possibilities of such a promotion. The potential of targeted advertising through Facebook would ensure those same subjects have quality segmentation and target market profiling in a form of direct marketing and a direct access to a big base of potential consumers. In the end, based on obtained results, a suggestion to advance the existing state is to encourage subjects of continental tourism to promote and advertise on social media, as well as to get acquainted with all the possibilities and advantages that such a way of promotion offers.

LITERATURE:

1. Ansari, A; Stahl, F; , Heittman M; Breme, L: *Building a Social Network for Success* Journal of Marketing Research, Vol. LV (June 2018), 321–338
2. Biloš, A., Ružić, D., Turkalj, D. (2014.): *e-Marketing v-3.0.*, Osijek: Sveučilište Josipa Jurja Strossmayera u Osijeku, Ekonomski fakultet u Osijeku
3. Boyd, D.M., Ellison, N.B. (2007.), *Socialnetworksites: Definition, history, and scholarship*,
4. *Journal of Computer Mediated Communication*, vol. 13, no. 1
5. Demeterffy Lančić, R. (2010.), *Novi mediji i odnosi s javnošću*, Medijske studije 1/1-24. Du, 5. Rex Y., and Wagner A. Kamakura (2011), *Measuring Contagion in the Diffusion of Consumer Packaged Goods*, Journal of Marketing Research, 48 (1), 28–47.
6. Hayden, J., Dunay, P., Krueger, R. (2012): *Facebook Marketing For Dummies*, New Jersey: John Wiley & Sons Inc.
7. Kesić, T. (2003.). *Integrirana marketinška komunikacija*, Zagreb: Opinio
8. Kickpatrick, D. (2010.). *Facebook efekt*, Zagreb: Lumen izdavaštvo d.o.o
9. Kwayu, S., Lal, B., Abubakre, M. (2018). *Enhancing Organisational Competitiveness Via Social Media - a Strategy as Practice Perspective*, Information System Frontiers, Vol 20, Issue: 3: 439-456
10. Murphy, T. (2010): *Getting real about Social Media, PR (and CRS)*, <http://tpemurphy.com/blog/?p=626>, 15.08.2018
11. Li, C; Bernoff, J (2010): *Veliki val, Kako pobijediti u svijetu novih društvenih tehnologija*, Mate, Zagreb
12. Nickson, C. (2014), *The History of Social Networking*, Digital Trend, , retrieved 30.05. 2018. from <http://www.digitaltrends.com/features/the-history-of-social-networking/>
13. Viet Hung, N., Zhuochuan, W. (2011.), *Practice of Online Marketing With Social Media in Tourism Destination Marketing – The case study of VisitSweden*, Södertörns University, Department of Business Studies, Huddinge
14. Zarella, D. (2009.) : *The Social Media Marketing Book*, O'Reilly Media, Cambridge, MA

15. Zavišić, S., Curić, M. (2013.): *Uloga i utjecaj društvenih mreža u ostvarivanju ciljeva marketinške kampanje*, Zbornik radova 1. međunarodne konferencije Fedor Rocco, Zagreb
16. Zavišić, S.; Luburić, G., (2013.), *The role of online social networks in promoting small and family hotels in Croatia*, Book of Proceedings „Marketing in a Dynamic Environment – Academic and Practical Insights“, 23. kongres CROMAR, Lovran
17. Zavišić, S., Mijatović, A. (2015), *Društvene mreže u funkciji povećanja prodaje*, *Suvremena trgovina*, No. 6, 16-19

COST MANAGEMENT IN AIR TRANSPORT COMPANIES

Grzegorz Zimon

Rzeszow University of Technology, Poland,

gzimon@prz.edu.pl

ABSTRACT

Cost management is one of the most important processes in a company. Company managers try to adopt such a strategy that will lead to an optimization of the level of costs. This is a difficult task as in many cases the costs that theoretically could be avoided are the result of a conservative liquidity management policy. And this policy is to guarantee the financial security of an individual, which is the basis for effective management. Customer lending is also a cost that could be theoretically avoided but an aggressive policy in this area could have a negative impact on the sales volume. The business environment is also influenced by the company's cost management policy. These are various types of external phenomena that managers do not have influence on, for example, changes in raw material prices, state policy, and various types of conflicts. Therefore, managers need to focus their activities on their own cost management policy. In general, the basic and the simplest solution in the field of cost management is the reduction of wages. In many companies, in the short term it is effective, but there are industries such as air transport where cost reduction and seeking savings in this area is unacceptable. The aim of the article is to analyze cost management in an air transport company and present solutions that can lead to an optimization of non-cost expenditure in such units.

Keywords: *cost, management, air transport*

1. INTRODUCTION

Cost management is an extremely complicated process as costs arise in every area of an enterprise. Costs are present in every business process that takes place in an enterprise. In order to earn revenues, an enterprise needs to incur expenses that should be at the expense of it. There are industries of the enterprise where managers are constantly trying to optimize them. The simplest method that is used to reduce the level of costs is to look for savings in the area of remuneration or conduct a remuneration management policy to minimize its level. Often in enterprises, one tries to save money by outsourcing services. Perhaps such an action will lower the level of costs in the company, but it may negatively affect the relationship with the client. A very good example of such dilemmas is the organization of transport in commercial enterprises. Maintaining the internal transport department costs, but contractors are used to the transport services that the supplier performs for them. Ordering this kind of services to an internal company that evaluates its effectiveness mainly through the prism of time is not a good solution. Contractors, who have used the internal transport of the supplier, are accustomed to the fact that they can change the time and a place of delivery at any time. In the case of transport services, it is often impossible, or it may need to be negotiated. Another important issue in the case of cost management is the use of a cost cutting policy. Basing the strategy of cost optimization on the policy of "low prices" in the long run can only lead to the collapse of the enterprise. Low prices greatly reduce the quality of products or services. Certain industries base their functioning on high quality, inability and this is where air transport companies should be included. Lowering the quality means lowering the security of service provision. In this type of industry, one cannot allow this. In the case of cost management, it is worth paying attention to the fact that costs can be divided into two groups. The first group are the costs which the managers have an impact on - these are the company's operating costs and costs related to the provision of services or production and sales. The second group of costs are costs which the managers do not have completely influence on.

This group of costs includes taxes, fees that one enters into enterprises. From the point of view of transport companies, oil prices are a group of costs which the managers have no influence on. Oil and its price are a very sensitive material for changes in politics, crises and armed conflicts. Before these phenomena, managers of a transport company have no chance to secure themselves. In the case of cost management the key to its optimization process is their detailed records. A well-structured cost accounting system is a very good tool that allows making the right decisions aimed at costs reduction. After detailed accounting of costs, enterprises have a chance to introduce some tools that will optimize costs.

2. COSTS REGISTER SYSTEMS

When using a traditional cost account based on full real costs, an enterprise has a variety of cost accounting solutions at its disposal. According to these requirements, the cost records of the main operating activities can be kept (Sawicki, 2000, p.92):

- only by type (including only group accounts no. 4), it is a generic cost system. The company's managers receive information on the type of costs incurred, such as consumption of materials and energy, wages and salaries, material consumption, external services, taxes and fees, and social insurance. This accounting system is popular in commercial enterprises.
- only according to the places of creation (including only group accounts no. 5) with a possible further division for the purposes of calculating production costs for direct and indirect costs - so-called functional and calculating system. This system of records allows determining the areas of costs incurred, e.g. the department of primary production, the board's department, the sales department, the auxiliary production department.
- full cost records using group accounts no. 4 and 5 in total. It is a full cost accounting system, it provides the most information about the costs incurred.

In the first two cases, there are simplified variants of the cost accounting for basic operating activities. In order to detail the picture of the incurred costs by type, it is worth entering auxiliary accounts in transport companies related to logistics. In air transport enterprises, the largest share of costs are those related to the purchase of means of transport, fuel consumption, costs of maintenance repairs, remuneration of pilots, insurance. For these cost items in each enterprise an appropriate system of cost accounting should be created which would provide detailed information on the costs of the service, places and type of costs that were significantly exceeded in relation to the planned values.

3. METHODS OF COSTS MANAGEMENT IN THE AIR TRANSPORT COMPANY

The process of cost optimization in an enterprise requires appropriate management methods. An additional difficulty is emerging of price warriors in virtually every industry. These are the units that are trying to effectively compete with enterprises that are market leaders by offering contractors a low price. Price warriors gain their advantage by offering a given product only in the basic version, focusing on only one segment of customers, have small headquarters and are able to maintain a low level of costs at any time. In the air transport industry, price warriors include SouthWest Airlines and JetBlue (Kumar, 2007, pp 75-87). They are cheap airlines which very often at the expense of lowering the level of quality of services they offer low prices. Air transport is an industry for which the application of the low price strategy provides some opportunities to reduce the level of costs, it is important that it does not take place at the expense of lowering the security of services provided. The safe tools coming from management accounting or finance, the application of which may lead to optimization of the level of costs can include:

- Analytical accounts of logistics
- Group purchasing,
- Benchmarking.

Analytical accounts of logistics - the basis for efficient cost management, optimization of their level is a detailed system of cost accounting. Using the chart of accounts, creating analytical accounts for the most important cost items is the first step that needs to be taken. This is within the reach of the company because managers can give instructions on how to prepare ancillary accounts to group costs, which the accounting and IT department of each company is able to do. In the table no. 1 below the typical accounts of group no. 4 are presented, for which sample solutions of logistics cost accounting are given.

Table 1: Typical chart of accounts of group no.4 including logistics costs (Zimon, 2016, pp.155-164)

Control accounts	Logistics analytical accounts
Depreciation	<ul style="list-style-type: none"> • Depreciation of motor vehicles • Depreciation of other fixed assets related to logistics
Materials and energy consumption	<ul style="list-style-type: none"> • Consumption of logistics materials • Fuel consumption • Consumption of energy for logistics purposes
External services	<ul style="list-style-type: none"> • Transport • Loading and unloading • Leasing • Telecommunications services • Repair services • Other external services
Remunerations	<ul style="list-style-type: none"> • Drivers' remunerations • Warehouse workers' remunerations • Other logistics workers' remunerations
Social securities and other benefits	<ul style="list-style-type: none"> • Social security and other benefits for drivers, e.g. <ol style="list-style-type: none"> 1. ZUS (Social Insurance Institution in Poland) contributions, 2. training, expenses on health protection, 3. Expenditure on Occupational Safety and Health • Social security and other benefits for other logistics workers', e.g. <ol style="list-style-type: none"> 1. ZUS (Social Insurance Institution in Poland) contributions, 2. training, expenses on health protection, 3. Expenditure on Occupational Safety and Health
Taxes and charges	<ul style="list-style-type: none"> • Motor vehicle taxes • Taxes on logistics property • Environment protection charges • Other charges, e.g. stamp duties, court fees
Other costs classified by their nature	<ul style="list-style-type: none"> • Insurance • Business travels of logistics workers • Other costs

Keeping cost accounting records this way would inform about their nature and function. The sample way of fuel consumption costs accounting is presented in the figure below.

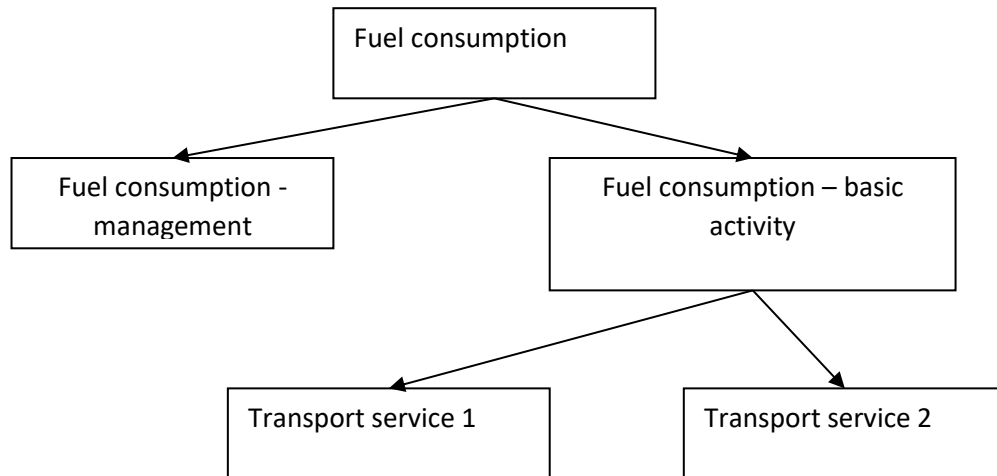

Figure 1: Analytical accounts of logistics

Source: author's own work

In the case of cost records on accounts according to cost centers, the following group accounts no. 5 are used:

- Costs of core operations, costs directly related to the basic activity of the entity (production, service or commercial). In manufacturing companies, these are the costs of manufacturing products (direct and indirect production costs). In services, these will be the costs of the service, e.g. transport costs.
- Costs of auxiliary production, costs directly related to auxiliary activities of the unit (production, service or commercial), e.g. costs of functioning of own boiler house, renovation department.
- Management costs, overhead costs, recognized according to cost centers in departments such as marketing, logistics, administration, etc.
- Costs of sales, costs related to the sale of products, e.g. advertising costs, transport costs to the recipient, commissions for traders.

The examples of the use of auxiliary accounts for account group number 5 are shown in figure 2 below.

Figure following on the next page

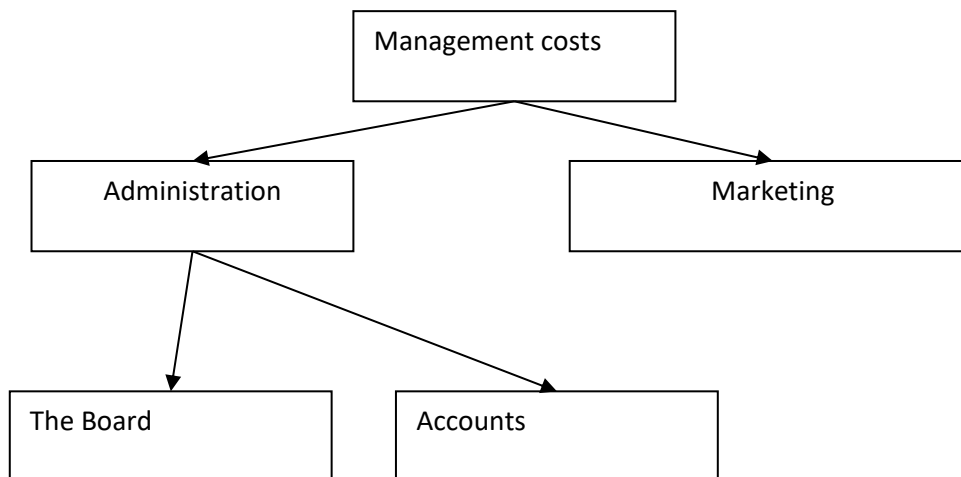

Figure 2: The examples of the use of auxiliary accounts for account group number 5
Source: author's own work

The use of full cost records along with auxiliary accounts for logistics provides detailed information on the costs of the business. In the case of enterprises dealing with air transport, the basic cost items are costs of fuel consumption, remuneration, costs related to the purchase and maintenance of means of transport. These are the items for which managers need detailed information as this gives them a chance for their subsequent reduction. In honor of these items, the company's managers are not affected by, for example, fuel costs. Oil prices are dictated by producers. However, there are some tools that can be used to safely reduce the level of costs incurred. Group purchases are a method of cost optimization, mainly used in group purchasing organizations (GPOs) Joint purchase within GPOs mobilizes individual enterprises to cooperate because the price depends on the total amount of purchased goods (Zhou, Xie, 2014 pp.42-52). This rule also applies to group purchases. Group purchasing was already popular in ancient Egypt (Wooten 2003, pp. 4-7), the joint purchase is designed to reduce prices (Snyder, 1998, pp. 205-209), such activities are very popular in small and medium-sized enterprises (Essig, 2000, pp.13-22). Inferioration of administrative costs (Tella & Virolainen, 2005, pp. 61-168), reduction of administrative costs (Nollet & Bealulieu, 2005, pp. 1-17) and cost reduction (Burns & Lee, 2008, pp. 203-215). One does not have to be a member of a purchasing group to use group purchasing. There are more and more situations when enterprises do not merge into purchasing groups, but only decide to make a purchase together. To this end, they use various types of Internet portals. Ensuring a lower price for customers by collecting a large number of orders and using the economies of scale is the basic concept of online group shopping (Kauffman & Wang, 2002, pp.99-137). In companies related to air transport, there is a large area for the use of group purchases. Joint purchase allows achieving economies of scale, which enables to accept a stronger negotiating position in negotiations with the producer. It is a way for buyers to gather bargaining power (Chipty and Snyder, 1999, pp.326-340). In the aviation industry, companies do not function as part of purchasing groups, but instead try to take advantage of economies of scale and take advantage of group purchases. In Europe, in the aviation industry, Luftansa, SAS (Dana, 2012, pp. 470-485). In principle, in the case of purchase of materials, fixed assets, oil of this type of operation allows reducing the level of costs.

Benchmarking is a management accounting tool whose main task is to find a way to solve an emerging problem. Benchmarking applies when the management believes that there is no possibility of solving problems on their own, in connection with potential, resources and knowledge (Kowalak, 2009, p. 15). The authors define benchmarking as the process of comparing themselves to the best competitors and then setting goals in such a way that our organization becomes competitive. (Belm 1992, p. 32). The task benchmarking is to compare and evaluate the products and processes of the business entity in the context of those organizations that are considered the best "in a given class". This is a typical comparison method for the client which was transfer red to the organization. The process of benchmarking involves the comparison of operational processes. Most often, it involves a comparison with a model enterprise. An example of this is procurement logistics, distribution, organization of warehouse work. Benchmarking processes can be divided into: (Gabrusewicz, Kamela-Sowińska, Poetschke, 2002, p. 269):

- Comparison with the best within the organization, e.g. between departments,
- Comparison with the best from outside the organization,
- Comparison with the best in terms of functionality

Benchmarking can also be used in strongly developed organizations where one can compare individual faculties with the model department, the leader. The disadvantage and difficulty that arise in the case of benchmarking will be the limitations resulting from the inability to obtain the necessary information. An example of this is the situation when a company wants to compare a certain process with an enterprise that is a leader in a given market, but also a major competitor. There are hardly any chances of getting the necessary information to conduct benchmarking in this case. The barrier related to obtaining information is the biggest problem when using benchmarking. Air transport enterprises, those large ones that are well developed, have a good chance of using internal benchmarking. In this case, the lack of information is missing. If they compare a given process, for example customer service, internal logistics, they get a lot of information about the advantages and disadvantages of a given process. The emerging joint purchases in the air transport industry show that companies notice that together they can do more. There is a clear sign that one can try to apply external benchmarking and make a comparison to the company they are working with.

4. CONCLUSION

Air transport enterprises are doomed to incur high expenditure, especially this related to the purchase of transport means. Subsequently, operating costs and fuel consumption are the next major items in the cost structure. In the case of these cost groups, the use of a policy consisting only of cost reduction, or the search for cheaper alternatives is a disastrous strategy of cost management in air transport companies. The first stage leading to the optimization of the level of costs should be an application of solutions, a tool derived from accounting that will not reduce the quality of services provided by air transport companies. These methods include the introduction of detailed cost records with the creation of appropriate analytical accounts for logistics for costs from groups 4 and 5. The introduction of full cost records will strengthen the controlling process in the area of costs. The next method is the use of group purchases. Joint purchases and the use of economies of scale will allow acquiring at lower prices assets that will be of high quality. Certainly, the high quality of services provided in this type of enterprises will positively affect the level of sales. Establishing cooperation with other enterprises during group purchasing organization creates a way to use the last tool discussed, i.e. benchmarking. The possibility of using benchmarking, i.e. learning from the best, in various areas of the company's operation, is a great opportunity for managers to optimize the level of costs without the need to reduce the quality of services.

LITERATURE:

1. Balm, G.J., (1992). Benchmarking. A practitioners guide for becoming and staying Best of the Best, QPMA Press, Shaumburg
2. Burns, L.R., Lee, J.A. (2008). Hospital purchasing alliances: Utilization, services, and performance. *Healthcare Management Review: July/September*, 33(3).pp.203-215_DOI: 10.1097/01.HMR.0000324906.04025.33.
3. Chipty, T., Snyder, C.M., (1999). The role of firm size in bilateral bargaining: a study of the cable television industry. *Review of Economics and Statistics* 81, pp. 326–340.
4. Dana, J.D. (2012). Buyer groups as strategic commitments, *Games and Economic Behavior* 74 (2012) 470–485.
5. Essig M., (2000). Purchasing consortia as symbiotic relationships: developing the concept of “consortium sourcing” *European Journal of Purchasing & Supply Management, Volume 6, Issue 1*, March 2000, Pages 13-22
6. Gabrusewicz, W., Kamela-Sowińska A., Poetschke H., (2002). Rachunkowość Zaradcza, PWE, Warszawa.
7. Kauffman,R.J., Wang,B. (2002). Big together, buy together: On the efficacy of group-buying business models In Internet-based selling.In P.B.Lowry, J.O.Cherrington,&R.R.Watson(Eds.), *Handbook of Electronic Commerce In Business and Society* (pp.99–137). Boca Raton, FL:CRC Press
8. Kowalak, R., (2009). *Benchmarking jako metoda zarządzania wspomagająca controlling przedsiębiorstwa*, Wydawnictwo Uniwersytetu Ekonomicznego we Wrocławiu, Wrocław
9. Kumar, N., (2007). Strategie walki z rywalami, których orężem są niskie koszty. *Harvard Business Review Polska*, Marzec 2007, pp. 75-87.
10. Nollet, J., Beaulieu M. (2005). Should an organization join a purchasing group? *Supply Chain Management*. 10(1).pp.11-17.
11. Sawicki, K., (2000). *Analiza kosztów firmy*, PWE, Warszawa.
12. Snyder, C.M., (1998). Why do larger buyers pay lower prices? Intense supplier competition. *Economics Letters* 58, 205–209.
13. Tella E., Virolainen V.M. (2005). Motives behind purchasing consortia. *International Journal of Production Economics*.pp.161-168.
14. Wooten, B., (2003). Cooperative purchasing in the 21st century. *Inside Supply Management* 14 (2), s. 4–7.
15. Zhou Y., Xie J. (2014). Potentially self-defeating: Group buying in a two-tier supply chain, *Omega* 49, pp.42-52.
16. Zimon, G. (2016), Accounting tools vs. logistic costs control in a trading company, *Logforum*, 2016 12(2), pp. 155-164.
17. Zimon, G. (2018), Influence of group purchasing organizations on financial situation of Polish SMEs, *Oeconomia Copernicana*, Volume 9, Issue 1, March 2018. pp.87-104.

COMPARATIVE ANALYSIS OF SELECTED AREAS OF MARITIME ECONOMY OF THE BALTIC SEA REGION COUNTRIES

Katarzyna Skrzyszewska
Gdynia Maritime University, Poland
k.skrzyszewska@wpit.am.gdynia.pl

ABSTRACT

The degree of differentiation of the BSR countries is enormous when it comes to the degree of development of the national economy. This is due to the fact that after the Second World War the Baltic States as dependent on the Soviet Union and Poland under the influence of the Soviet Union were countries with irrational and ineffective socialist economy. At the end of the 1990s, the process of systemic transformation began in these countries, which although completed did not compensate for differences in the level of economic development of the countries of the Baltic Sea basin. With regard to a part of the national economy - the maritime economy, the issues of differences and delays are not so visible due to the nature of this sector. The maritime economy as the most globalized economic activity, even in socialist countries, was to a certain extent based on market principles. The European Commission, striving to achieve equal living standards in Europe, created development strategies on various levels (regional – the European Union Strategy for the Baltic Sea Region, EU - Europe 2020, sectoral – the Integrated EU Maritime Policy), whose task is to achieve continuous and sustainable development, inter alia, in sectors of the economy based on sea resources (maritime economy) of the European Union, including the Baltic Sea Basin region. The aim of the research was to compare and determine the level of development of selected types of maritime economic activity in the Baltic Sea Region countries in the period from the publication of the Integrated Maritime Policy (IMP) for the EU (i.e. from 2007) to 2016. In the paper the method of analysis and logical construction was used. An analysis of selected aspects of economic activity within the maritime economy was performed and then a synthesis was carried out. The relationships detected in this process were examined with the use of selected statistical measures.

Keywords: *Baltic Sea Region, Integrated Maritime Policy for the EU, maritime economy, maritime transport*

1. INTRODUCTION

The Integrated Maritime Policy for the European Union adopted in 2007 (COM (2007) 574 final) was the effect of noticing an increasing number of problems related to sea and ocean areas. These problems concerned more and more intensive exploitation of seas - both in terms of the scope of activity and its intensity. Due to a growing number of people using marine resources - the marine environment has become a place of growing conflicts of interest. Unsustainable exploitation of marine resources is a source of potential economic threats (maritime transport, food production, electricity production) as well as ecological threats (climate regulation, impact on marine flora and fauna, and indirectly on health and well-being of people). The EU maritime policy proposes that '(...) all issues related to the oceans and seas of Europe (...) should be led in an integrated manner' (COM (2007) 574 final, p. 2). Among five areas of action, around which the EU Integrated Maritime Policy is focused, the first to mention is maximization of the sustainable use of oceans and seas. In this area, the most important were: sea transport, seaports and shipbuilding. The choice of these areas of activity resulted from their importance in development of modern economies, which was confirmed in subsequent EU strategic documents: Strategic goals and recommendations for the EU's maritime transport policy until 2018 (COM (2009) 8 final), Blue Growth opportunities for marine and maritime sustainable growth (COM (2012) 494 final), Towards more sustainable

growth and jobs in the blue economy (SWD (2017) 128 final). Maritime transport is the foundation of the maritime economy - creating demand for products and services of other industries concentrated in the maritime cluster. It is one of the main driving forces of Europe's development - on the one hand, the sector which is susceptible to globalization, on the other hand – one that is shaping this globalization. Its key role in development of the world results from the lack of an alternative to transporting cargo by sea. This is a consequence of uneven distribution of centres of extraction of natural resources, places of their transformation and places of consumption of final goods obtained from given resources. The lack of substitutes for sea transport in the case of large and heavy batches of long-distance transports does not preclude external substitution - reduction of demand for transport services due to localization of processing activities near places of resource extraction. However, external substitution cannot offset the demand for transport services in general - finished products, manufactured close to extraction sites, should be provided to potential buyers - which in turn again generates the demand for maritime transport services. This may be a demand for services of other vessels, but it does not eliminate transport needs by sea as such (Skrzeszewska, 2016, pp. 313-314). Sea transport is also one of the cleanest and the most environmentally friendly. Maritime transport and the sectors developing around it, including ports and shipbuilding industry listed in IMP, is the source of wealth of nations with a coastal location. This is mainly due to the economic potential of shipping itself and the sectors operating for it. Research conducted over the years by Oxford Economics confirms this thesis. Direct, indirect and induced effects of sea navigation have a significant impact on the economic activity of regions, where maritime transport operates. According to the latest report, the EU maritime sector directly employed 640,000 people, and the sector's contribution to GDP reached € 57 billion. Considering the supply chain, the number of jobs generated thanks to maritime transport reaches 2.1 million, and the share in generating GDP is estimated at € 140 million (Oxford Economics, 2017, pp. 16-17). Seaports are an important link in the logistics chain, as development of regions, in which they operate and of the entire economic area of the EU depends on their capacity and performance. This is so because ports provide territorial continuity to the EU, in particular by handling connections with islands and peripheral areas (COM (2013) 295 final, p. 3). Shipbuilding and repair yards are, in turn, an indispensable element in the value chain created by maritime transport. Shipbuilding industry was recognized as a sector of strategic importance for the EU, and issues related to its development were developed by CESA (Community of European Shipyards Associations) and announced in 2004 as the LeaderSHIP 2015 program, replaced in 2013 by LeaderSHIP 2020. The Sea, New Opportunities for the Future (LeaderSHIP 2020, 2013, p. 3).

2. SELECTED ELEMENTS OF MARITIME ECONOMY IN THE COUNTRIES OF THE BALTIC SEA REGION

The uniqueness of the Baltic Sea Region results from at least two reasons: it is a peripheral region in the EU - located on the north-eastern borders of the Union, far from the geographical and economic centre, and additionally it is a region with a large diversity of socio-economic potential (Klemeshev et al., 2017, pp. 4-20). The diversity concerns both the area of countries, the number of inhabitants and the basic economic indicator - GDP. Hence, while characterizing the region, it is necessary to distinguish coastal regions and take into account disproportions in the size of populations living in particular countries of the BSR (Table 1).

Table following on the next page

Table 1: Population of BSR countries including coastal regions (Eurostat)

Country	Population, 1st January [number]		Population in coastal regions as percentage of the total population [%]	
	2007	2016	2007	2015 ²
Denmark	5 447 084	5 707 251	96	96
Germany	82 314 906	82 175 684	n. a. ¹	n. a.
Estonia	1 342 906	1 315 944	75	76
Latvia	2 208 840	1 968 957	62	64
Lithuania	3 249 983	2 888 558	11	11
Poland	38 125 479	37 967 209	10	10
Finland	5 276 955	5 487 308	63	64
Sweden	9 113 257	9 851 017	81	82

¹ the list lacks information on population of the coastal region – no data in Eurostat. Study on Blue Growth, Maritime Policy and the EU Strategy for the Baltic Sea Region states that in 2010, 1.74 million people lived on the coast (4.28% country's labour force: 2.62% in the Baltic Sea Region and 1.67% in the North Sea Region) (Study on Blue Growth ..., 2013, p.12).

² data for 2016 is still incomplete (May 2018).

In the analyzed period, the percentage of population living in coastal regions in particular countries was stable (an increase of 2 percentage point was recorded in Latvia, by 1 percentage point in Estonia, Finland and Sweden). In addition to three countries of the Southern Baltic (Germany, Poland and Lithuania), a greater part of population of the countries in the studied region live on the coast. However, taking into account the size of population of particular countries, it can be concluded that the average number of population coastal areas in Poland and Germany is similar to other countries (the exception is Lithuania). In the vast majority of countries, population of coastal regions is concentrated within 15 km of the shoreline (Eurostat). Analyzing the GDP per capita in particular countries, it can be noticed that the convergence process of economies of the former Eastern bloc is still ongoing, and the difference in the level of development measured by GDP is still huge (Table 2).

Table 2: Gross domestic product (GDP) per capita, at current market prices (national; coastal regions levels) [thousands euros] (Eurostat)

	2007	2008	2009	2010	2011	2012	2013	2014	2015	2016
Denmark	43 ¹ ; 41 ²	44; 42	42; 41	44; 42	45; 43	46; 44	46; 45	47; 46	48; 47	48; 48
Germany	31; n. a.	32; n. a.	31; n. a.	32; n. a.	34; n. a.	34; n. a.	35; n. a.	36; n. a.	37; n. a.	38; n. a.
Estonia	12; 13	12; 13	11; 12	11; 12	13; 14	14; 15	14; 16	15; 16	16; 17	16; 18
Latvia	10; 13	11; 14	9; 11	9; 10	10; 12	11; 15	11; 16	12; 16	12; 17	13; n. a.
Lithuania	9; 9	10; 11	9; 9	9; 10	10; 11	11; 12	12; 13	13; 13	13; 13	14; n. a.
Poland	8; 8	10; 9	8; 8	9; 9	10; 9	10; 9	10; 9	11; 10	11; 10	11; n. a.
Finland	35; 39	37; 40	34; 38	35; 39	37; 40	37; 40	37; 41	38; 41	38; 42	39; n. a.
Sweden	39; 40	38; 39	33; 35	39; 41	43; 44	45; 46	45; 47	45; 46	46; 47	47; n. a.

¹ national level, ² coastal region level

While in the north-western part, GDP per capita fluctuates around 38-48 thousand Euro (in current prices), in the south-eastern part the value of this index is 3 times lower - from 11 to 16 thousand Euro (in 2016) (Eurostat). However, another approach to the issue of GDP shows some similarities between the coastal parts of the countries of the region. Percentage of GDP per capita in current prices, developed in coastal regions, is usually higher than the average

GDP per capita calculated on a national scale. The only exception is Denmark (with the highest GDP per capita in the BSR) and Poland (where this indicator is the lowest one).

3. ANALYSIS OF RESULTS OF OPERATIONS OF SELECTED SECTORS OF THE MARITIME ECONOMY

3.1. Transshipment

In the Baltic Sea region, both in 2007 and 2016, the largest transshipments were recorded in German ports (315 and 295 million tonnes, respectively). Regarding this country, however, it must be remembered that its ports are located both on the Baltic coast and the North Sea. And these are German ports over the North Sea which generate much bigger trans-shipments. Germany is followed by Scandinavian ports: Swedish, Finnish and Danish ports respectively (Tab. 3.).

Table 3: Gross weight of goods handled in all ports of the Baltic Sea Region - country level [thousand tonnes] (Eurostat)

	2007	2008	2009	2010	2011	2012	2013	2014	2015	2016
Denmark	109 660	106 096	90 636	87 068	92 613	87 827	88 406	92 244	95 098	95 899
Germany	315 051	320 636	262 863	275 953	296 037	298 758	297 281	303 742	295 918	297 137
Estonia	44 964	36 191	38 505	46 026	48 479	43 519	42 908	43 578	34 965	33 596
Latvia	61 083	61 430	60 088	58 691	67 016	72 723	67 148	71 836	67 811	60 962
Lithuania	29 253	36 379	34 344	37 869	42 661	41 033	39 757	41 105	43 128	46 236
Poland	52 433	48 833	45 079	59 507	57 738	58 825	64 282	68 744	69 530	72 926
Finland	114 819	114 725	93 239	109 326	115 452	105 120	105 117	105 537	99 962	105 887
Sweden	185 057	187 778	161 823	179 579	177 093	172 976	161 570	167 530	169 685	171 324

In the case of the Southern Baltic countries, the scale of transshipment is much lower - it accounts for 10 to 25% of cargo from German ports, or 20-40% of cargo handled in Swedish ports. The mere turnover of commodities is not enough to determine how particular countries use trade potential. It is worth looking at the main trading partners of the BSR countries on this occasion. In Table 4, all the countries analysed are listed in rows. All potential trading partners from this region are listed in columns. The number *n* in a cell means that for a country, whose name appears in the row, the country, whose name appears in the column is the *n*-th largest trading partner.

Table 4: The main trading partners of the Baltic Region countries (prepared on the basis of: UNCTAD)

	Denmark	Germany	Poland	Lithuania	Latvia	Estonia	Finland	Sweden
Denmark		1						2
Germany								
Estonia		1						
Latvia		4	3		2	5		
Lithuania		4		1		2		5
Poland				5	4		2	1
Finland		1						2
Sweden	4	1					5	

When preparing the table, only five most important trading partners of each country in the BSR region were included. The table shows that Germany is the most important trading partner in the region. It is the largest trading partner for: Denmark, Poland, Finland and Sweden. Equally important, though not the most important trading partner, is Germany for Lithuania and Latvia. The next country, with which the most countries of the region trade, is Sweden. It is the main

trading partner of Estonia, the second is Finland and Denmark and the fifth is Latvia. The position of the main trading partner is directly connected with the results of cargo handling in ports. Germans are the undisputed leader in this field, and Swedes are on the second place. In absolute terms, the least cargo handling takes place in the Baltic States, but if the number of inhabitants of these countries is taken into account, it turns out that the leader in trans-shipment in ports, measured in tonnes *per capita* are (in 2016): Latvia (31.1 tonnes / pc), Estonia (25.5 tonnes / pc) and Finland (19.3 tonnes / pc) (Eurostat). Port development associated with many geographical, economic, political and infrastructural factors has a huge impact on development of the local coastal area economy. The activity of ports and sectors centred around ports is of great importance for the region in every respect: gross value added, taxes paid to the state treasury and local budgets, as well as jobs. It is estimated that one workplace in the port generates from 20 to 25 jobs in the sectors operating for the port and in the economy, as a result of direct, indirect, induced and catalysed effects (Oxford Economics, 2012, p. 3), (Matczak, 2016, p.36).

3.2. Merchant Navy

Each country of the Baltic region has its own fleet, which is to a greater or lesser degree registered under the national flag. Owning ships under the country's own flag brings enormous economic benefits, as well as non-economic and prestigious benefits to fleet owners. Although nowadays it is rare that the fleet belongs entirely to the state treasury as in the times before the political transformation, but even so private ownership of the fleet generates many benefits for the economy and the society, too. Ships registered under the flag of a given country generate many sources of revenues to the state budget: registration fees, fees for inspecting ships by the Flag State Inspection (FSC), tonnage tax or business activity taxes, direct and indirect taxes on employees, whose jobs are created by shipping (indirect and induced effects). Analyzing the size of the trade fleet of the countries of the region, the first conclusion that can be drawn is a loss of transport potential by almost all the BSR countries (the exception is Denmark). To better illustrate this situation, changes in the size of the fleet (in DWT) were presented in a broader context (from 1993) and broken down into north-western and south-eastern countries (after systemic transformation) (Fig. 1A, 1B).

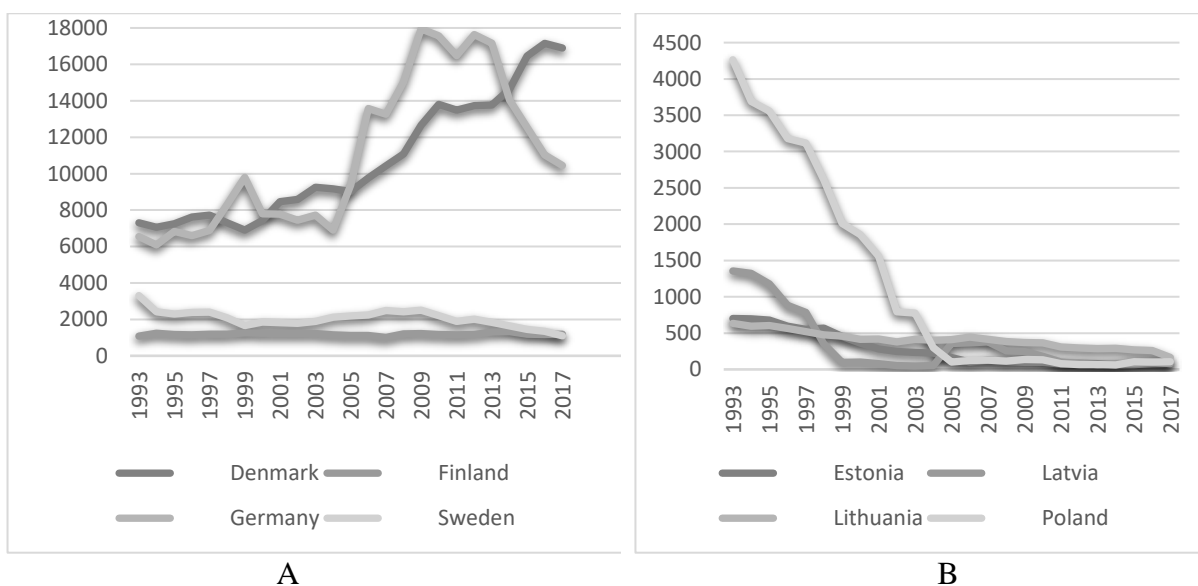

Figure/Chart 1: The size of the commercial fleet (in thousands DWT) of the North-West Baltic (A) and the south-eastern Baltic (B) (UNCTAD)

While at the beginning of the 1990s, the fleets of these countries were equal with regard to the size of the of fleets of Finland or Sweden, over the period of 25 years they almost disappeared. The reasons for this are varied, but due to the size limits of the paper – they will be omitted here. In order to counteract the loss of the fleet, many BSR countries undertook actions aimed at making the conditions of operation of the fleet under the national flags more attractive. The most frequently used policy instrument was a tonnage tax, i.e. the form of taxation of shipping operations, independent of the financial result of operations. It was introduced in: Germany, Denmark, Poland, Latvia, Finland and Sweden. The effects of the implemented solutions, apart from Denmark, did not bring the expected results. In view of the above facts, the Baltic Europe does not count as the region with strong transport potential, despite two large fleet of Germany and Denmark.

3.3. Shipyards

The European maritime technology industry encompasses all the enterprises involved in the design, construction, maintenance and repair of all types of ships and other relevant maritime structures, including the complete supply chain of systems, equipment, services and supported by research and educational institutions (European Commission, 2013, p. 1). Similarly to sea sailing and seaports, the shipyard sector is an important element in implementing the Europe 2020 development strategy, in particular its part related to knowledge and innovation-based development as well as more efficient use of resources in a more environmentally friendly way. The shipbuilding industry of the Baltic Sea Region has an established and stable position in the European Union at the level of approx. 17% of the value of production in this sector (Table 5).

Table 5: The largest shipyard manufacturers in Europe (by production value) with regard to their market share in the EU and regional market (PRODCOM 2008, ..., 2017)

	2007	2008	2009	2010	2011	2012	2013	2014	2015	2016
Ships Value (of the whole BSR production as a % of the EU production) [%]	9.5.	19.95	13.25	22.04	18.91	17.17	17.57	16.06	16.95	17.71
1 st producer in the BSR	FI	DE	FI	DE	DE	DE	DE	DE	DE	DE
Ships Value (of the 1st producer as % of the whole BSR production) [%]	44.95	48.79	58.53	58.20	65.90	51.80	53.16	56.99	49.23	42.36
Ships Value (of the 1st producer as % of the whole EU production) [%]	4.27	9.74	7.76	12.83	12.32	8.89	9.34	9.15	8.34	7.50
2 nd producer in the BSR [%]	PL	FI	DE	FI	FI	FI	FI	FI	FI	FI
Ships Value (of the 1st producer as % of the whole BSR production) [%]	34.50	36.04	21.42	28.00	15.32	26.34	28.64	25.61	31.23	35.52
Ships Value (of the 1st producer as % of the whole EU production) [%]	3.28	7.19	2.84	6.17	2.90	4.52	5.03	4.11	5.29	6.29
3 rd producer in the BSR	SE	PL	PL	PL	PL	PL	PL	PL	PL	PL
Ships Value (of the 1st producer as % of the whole BSR production) [%]	8.07	9.83	13.96	7.39	14.87	13.64	10.48	11.91	13.65	16.62
Ships Value (of the 1st producer as % of the whole EU production) [%]	0.77	1.96	1.85	1.63	2.81	2.34	1.84	1.90	2.31	2.94

The undisputed leader in the BSR shipbuilding industry is Germany. Its share in the value of the entire regional production oscillates around 50%, which accounts for about 10% on the EU scale. The largest value expressed in monetary units is obtained by German shipyards thanks to production classified as ‘motor boats and motor yachts for pleasure or sports’ (PRODCOM,

2017). Finnish shipyards rank second with a 25% market share in the regional market and around 5% share in the EU market. The Finns' domain is 'fitting out services of ships and floating structures and structures' (PRODCOM).

Poland with 10% in the regional market and around 2.5% share in the EU market specializes in 'conversion and reconstruction of ships, floating platforms and structures' (PRODCOM).

4. CONCLUSION

The Baltic Sea, although located on the periphery of the European Union, is an important area for EU. Apart from three countries (Germany, Poland, Lithuania), the majority of the Baltic Sea Region (BSR) citizens live in coastal regions, which means that the sea is an important source of livelihood for many BSR residents and an attractive place to live. The potential of the economy based on marine resources can be demonstrated by the fact that in the vast majority of countries, GDP per capita in coastal regions is higher than national GDP per capita (with the exception of Denmark and Poland, and in the case of Germany – this data is inaccessible). Attractiveness of the sea as a place of business and a place to live caused that conflicts of interests of entities using marine resources arose and began to intensify. In order to prevent negative effects of these conflicts and to use marine resources in an economically and ecologically optimal way, a number of strategic documents have been developed that set priorities in the use of marine resources. One of them is the Integrated Maritime Policy EU (IMP), which outlines the necessity of sustainable exploitation of marine resources and the most important areas for development of economic activity are: maritime transport, handling goods in maritime ports and shipbuilding. The data analysis regarding activities listed in the IMP showed that while differences in economic development of Western European countries and countries that underwent the systemic transformation are still visible, differences in the maritime economy are not so important. With regard to cargo handling in seaports, the largest turnover in the period considered was recorded in Germany, Sweden and Finland. However, taking into account the number of inhabitants in particular countries, the largest handling in tonnes per capita was recorded in Latvia, Estonia and Finland. With regard to the maritime fleet, all (except Denmark) countries of the region have reduced their potential. The phenomenon affected the Baltic States and Poland to the greatest extent. With regard to shipbuilding activity - the region provides about 1/5 of the value of production of the entire European Union. These are primarily specialized constructions and special purpose units. The leaders, with a well-established and stable position throughout the entire period considered, are Germany, Finland and Poland. Diversified sets of leaders in individual, strategically important areas allow formulating the statement that all the BSR countries benefit economically benefits from the Baltic Sea and their common goal should be as much care as possible for sustainable exploitation of its resources.

LITERATURE:

1. COM(2007) 575 final, COMMUNICATION FROM THE COMMISSION TO THE EUROPEAN PARLIAMENT, THE COUNCIL, THE EUROPEAN ECONOMIC AND SOCIAL COMMITTEE AND THE COMMITTEE OF THE REGIONS - *An Integrated Maritime Policy for the European Union*. Retrieved 20.05.2018 from <https://eur-lex.europa.eu/legal-content/EN/TXT/PDF/?uri=CELEX:52007DC0575&from=EN>.
2. COM(2009) 8 final, COMMUNICATION FROM THE COMMISSION TO THE EUROPEAN PARLIAMENT, THE COUNCIL, THE EUROPEAN ECONOMIC AND SOCIAL COMMITTEE AND THE COMMITTEE OF THE REGIONS - *Strategic goals and recommendations for the EU's maritime transport policy until 2018*. Retrieved 15.05.2018 from <https://eur-lex.europa.eu/LexUriServ/LexUriServ.do?uri=COM:2009:0008:FIN:EN:pdf>.

3. COM(2012) 494 final, COMMUNICATION FROM THE COMMISSION TO THE EUROPEAN PARLIAMENT, THE COUNCIL, THE EUROPEAN ECONOMIC AND SOCIAL COMMITTEE AND THE COMMITTEE OF THE REGIONS - *Blue Growth opportunities for marine and maritime sustainable growth*. Retrieved 17.05.2018 from https://ec.europa.eu/maritimeaffairs/sites/maritimeaffairs/files/docs/body/com_2012_494_en.pdf.
4. COM(2013) 295 final, COMMUNICATION FROM THE COMMISSION - *Ports: an engine for growth*. Retrieved 17.05.2018 from <https://eur-lex.europa.eu/LexUriServ/LexUriServ.do?uri=COM:2013:0295:FIN:EN:PDF>.
5. European Commission. (2013). *LeaderSHIP 2020 - The Sea, new opportunities for the future, European Commission, Enterprise and Industry*. Retrieved 22.05.2018 from file:///C:/Tymczasowe%20pliki%20internetowe/IE/MKJNN16I/leadership2020-final-report_en.pdf.
6. Eurostat. <http://eurostat.org.eu>
7. Klemeshev A.P., Korneevets V.S., Palmowski T., Studzieniecki, T., Fedorov G.M. (2017). Approaches to the definition of the Baltic Sea Region. *Baltic Region*. Vol. 9. No 4, pp. 4-20.
8. Matczak, M. (2016). *Report: Polish sea ports as the poles of the country's economic development in the regions*. Actia Forum. Retrieved 25.05.2018 from <http://actiaforum.pl/en/assets/files/realizacje/pdf/AF-BCT-raport-final.pdf>.
9. Oxford Economics. (2012). *The Economic Impact of the UK Maritime Services Sector: Ports. A report for Maritime UK*. London.
10. Oxford Economics. (2017). *The Economic value of the EU shipping industry. 2017 update. A report for the European Community Shipowners' Associations (ECSA)*. London. pp. 16-17.
11. PRODCOM, <http://ec.europa.eu/eurostat/web/prodcom/data/excel-files-nace-rev.2>
12. Skrzyszewska, K. (2016). Maritime Governance – Between Assumptions and Realizations. In D. Vasileno, N. Khazieva (eds.) *Proceedings of the 4th International Conference on Management, Leadership and Governance (ICMLG 2016)*. ACPI, UK.
13. *Study on Blue Growth, Maritime Policy and the EU Strategy for the Baltic Sea Region*. (2013). MARE/2012/07 - Ref. No 1 Final Report.
14. SWD(2017) 128 final, COMMISSION STAFF WORKING DOCUMENT - *Report on the Blue Growth Strategy. Towards more sustainable growth and jobs in the blue economy*. Retrieved 30.05.2018 from https://ec.europa.eu/maritimeaffairs/sites/maritimeaffairs/files/swd-2017-128_en.pdf
15. UNCTAD. <http://unctadstat.unctad.org/>.

A SMART CITY ASSESSMENT FRAMEWORK: THE CASE OF ISTANBUL'S SMART CITY PROJECT

Fatih Canitez

*Department of Management Engineering, University of Istanbul Technical, Turkey
fatihcanitez40@gmail.com*

Muhammet Deveci

*ASAP Research Group, School of Computer Science, University of Nottingham, UK
muhammet.deveci@nottingham.ac.uk; muhammetdeveci@gmail.com*

ABSTRACT

Smart city concept has gained importance in urban development literature and there have been many initiatives and projects around the world implementing the smart city concepts. There is a need for an assessment framework, customized for the local context. This study aims to offer a holistic assessment framework for smart city projects, which include smart city dimensions and application areas. The framework is then used for Istanbul's recent smart city project. The improvement areas are specified, and recommendations are made to increase the effectiveness of Istanbul's project by using this framework. The results show that technology as a dimension and smart mobility as an application area have the highest scores. Governance and institutional context dimensions as well as smart building and energy areas are recommended to be addressed more in the project. The framework can be used for other smart city projects around the world as well.

Keywords: *Smart city, Assessment framework, Application areas, Dimensions, Istanbul*

1. INTRODUCTION

Cities are the centers for development and innovation (Villa and Mitchell, 2009). Conceptualizing the processes whereby urban development happens is a major concern for the city authorities, planners and the industry related with urban development. Cities are also sources of wide-ranging socio-economic and environmental impacts (John et al., 2015; Aina, 2017). The concept of smart city has been gaining momentum recently to improve urban development and sustainability. There are various definitions of the concept of smart city (Albino et al., 2015; Angelidou, 2015; Caragliu et al., 2011). Although it has been mostly associated with Information and Communication Technology (ICT) (Townsend, 2013; Bulu, 2014; Bifulco et al., 2016; Niaros et al., 2017), smart city concept incorporates ideas such as smart governance, sustainability, institutional context as well as management and organization. On the other hand, assessment frameworks are still in infancy regarding the implementation of smart city concepts in an urban area. Understanding the local setting is quite important to adapt and adjust the smart city concepts (Neirotti et al., 2014). In this regard, an assessment framework is needed to assess the current condition of the urban context with regard to receptivity to any form of smart city application. Therefore, a framework should include not just the components or dimensions of smart city concept, but also application areas where those dimensions are operationalized. Although there are many studies providing different frameworks, strategies, guidelines and best practices (Giffinger et al., 2007; Lee et al., 2014; Angelidou, 2014; Roche, 2014), those frameworks generally focus on the dimensions and components of the smart city concept without delineating how those dimensions interact with application areas. Therefore, a framework which incorporates the dimensions with application areas is still needed and this paper provides such a framework which can be implemented in urban areas where smart city concepts are applied. Istanbul, with a population of nearly 14.8 million, is a mega-city having many urban problems such as urban mobility, infrastructure,

energy and environmental pollution. Istanbul Metropolitan Municipality (IMM) launched a smart city transformation project at the beginning of 2017. Various stakeholders are involved in the project. A subsidiary municipal company, which provides ICT solutions for Istanbul, is assigned as the coordinator for this project. It cooperates with one global and one local technology companies to deliver the projects planned for smart city transformation. After the studies analyzing the current situation of Istanbul; smart city vision, strategies and the roadmap for Istanbul are still in development phase as of the beginning of 2018. A Big Data Management Center is planned to manage the data generated from various urban activities such as mobility, energy consumption, waste management etc. so that this data can be utilized to provide higher quality urban services. The development of start-up firms which can use the open data provided from this center is also planned to bring about urban development and innovation. Internet of Things (IoT) projects, establishment of smart communication networks and operation centers, provision of energy automation systems, smart lighting and sensors, artificial intelligence solutions for energy, mobility, health and security are some of the examples for the planned projects. Criticized as the techno-centric view in the literature (Mora et al., 2017), the smart city project in Istanbul can be regarded to a large extent with a techno-centric view, which overlooks social, cultural, organizational and environmental dimensions of smart city application. For this reason, Istanbul can be a good case example where the proposed framework can be applied. In this study, the proposed framework which includes smart city dimensions and application areas is applied for Istanbul to improve the ongoing smart city project. With this assessment framework, it is expected that the smart city project can incorporate all the dimensions of smart city concept besides technological dimension. Those dimensions include management and organization, technology, governance, institutional context, community orientation, economy and financing, data and analytics, sustainability. At the same time, different application areas can be assessed with regard to their status vis a vis the dimensions. The application areas in our framework include smart building, mobility, infrastructure, technology, healthcare, citizen, governance and energy. The main contributions of this paper are (i) to provide an enlarged and holistic assessment framework for smart city projects, (ii) to apply this framework for Istanbul's smart city transformation project as a case study, and (iii) to expand the scope of techno-centric smart city projects with other important smart city dimensions. The rest of the paper is organized as follows. Section 2 presents a detailed literature review of smart city concept, applications, frameworks as well as best practices. A new assessment framework for smart city projects is developed in Section 3. The application of this framework for Istanbul is presented in Section 4. Results and discussions are given in Section 5. Lastly, Section 6 concludes the paper.

2. RELATED WORKS

The literature for smart cities presents many definitions, focusing on different aspects of the smart city concept (Albino et al., 2015; Angelidou, 2015; Lara et al., 2016). Kim et al. (2017) argue that the main characteristics of a smart city incorporate information technology integration and implementation of information resources. Smartness play an important role here, delineating various domains such as “smart technology, smart services, smart management and smart life”. On the other hand, Caragliu et al. (2011) views smart city as investing in human and social capital with modern ICT infrastructure to foster sustainable growth. Therefore, participatory governance and smart management of natural resources are underlined in this definition (Alawadhi et al., 2012). Deakin and Al Waer (2011) emphasizes the technological aspect of smart city concept. According to their definition, smart city is where ICT is applied and implemented to improve the quality of urban life. Digitalization of services is underlined by Seta et al. (2015) where all city functions are embedded in the technology infrastructure (Sarma and Sunny, 2016).

Furthering the techno-centric view, Batty (2013) emphasizes the role of big data in smart city concept and Jin et al. (2014) presents a framework for the realization of smart cities through the Internet of Things (IoT). Hall et al. (2000), on the other hand, brings an efficiency perspective to the definition of smart city, where all structures including transportation, water, energy are maintained using integrated ICT infrastructure, hence providing efficiently running urban services. Cocchia (2014) gives an extensive literature review of smart city concept, focusing on time, definition, terminology and geographic analysis. Lacinak and Ristjev (2017) underline the safety aspect of smart city and give the application areas as smart transport, smart energy, smart technology, smart living, smart environment, smart citizens and education, smart economy, smart government and safe city. Chourabi et al. (2012) and Dirks and Keeling (2009) regard the smart city as a large organic system composed of many subsystems and components. Morvaj et al. (2011) present those interconnected infrastructures as “citizens, water and energy, communication, business, transport and city services”. Different frameworks, dimensions and guidelines have been developed recently for the application of smart city concept. Giffinger et al. (2007) proposed dimensions for the smart city as “smart economy, smart mobility, smart governance, smart environment, smart living and smart people”. Albino et al. (2015) put forward the four main characteristics of smart city as “networked infrastructure, entrepreneurial and innovative urban development, social inclusion and natural environment”. Alawadhi et al. (2012) give eight categories or dimensions, and these are “technology, management and organization, policy context, governance, people and communities, economy, built infrastructure, and natural environment”. Different implementation frameworks are proposed by Battarra et al. (2016) and Lee et al. (2014). Lee et al. (2014) gives various components for smart city implementation, including “urban openness, service innovation, partnership formation, urban pro-activeness, smart city infrastructure and smart city governance”. Other important aspects of smart city implementation such as interoperability and scalability of the services (Angelidou, 2014), partnerships and collaboration (Breuer et al., 2014) are also emphasized in the literature. Besides, Anthopoulos et al. (2015) gives eight dimensions for the smart city conceptualization: “architecture, governance, planning and management, data and knowledge, health, energy, people and environment”. Other studies focus on different aspects of smart city concept. Mulligan and Olsson (2013) investigates the “system architecture evolution” needed to provide innovative business models for smart city applications. Nam and Pardo (2011a) offer strategic principles aligned with three dimensions; technology, people and institutions for smart city concept. They further emphasize the policy and management part of smart city, which are sidelined by the technology aspect (Nam and Pardo, 2011b) and also provide a risk-based view of smart city innovation. Lastly, Zygiaris (2013) addresses the smart innovation ecosystem by developing a “smart city reference model” and offers notions such as green, interconnected, instrumented, open, integrated, intelligent and innovating for this model. The concept also draws criticism from various perspectives. Hollands (2008) takes a critical view of smart cities, revealing the underlying assumptions and contradictions of the concept. Kitchin (2014) presents a critical account of smart city based on the implications of big data and smart urbanism. Vanolo (2014) focuses on power and knowledge implications of smart city concept and gives a discourse analysis.

3. ASSESSMENT FRAMEWORK FOR SMART CITIES

In smart city applications, a framework is required to incorporate different dimensions of smart city concept as well as different application areas. The literature review provided us with a general understanding of various dimensions and assessment frameworks. However, different local contexts require different assessment frameworks. Therefore, an idiosyncratic assessment framework needs to be developed for different settings. For this end, previous frameworks and their dimensions and characteristics can be used or adapted.

In this study, dimensions and application areas are merged to form an integrated framework. The rationale behind this is to present a comprehensive and holistic framework to monitor different dimensions and their status with respect to different application areas at the same time. This is particularly important where some dimensions and application areas are neglected. Istanbul's case presents such a setting where technology dimension tends to dominate the other dimensions and smart technology overrides other application areas. Table 1 gives the integrated framework that we developed for smart city applications. Each cell inside the framework shows the maturity level with respect to the corresponding dimension over the application area. The maturity levels take values from 1 to 5, depending on how a specific dimension of smart city concept is well applied on a specific application area. For example, if governance dimension of smart city is not well addressed and applied in smart healthcare, then the corresponding cell takes lower values.

Table 1: Smart City integrated assessment framework

		Application areas							
		Smart building	Smart mobility	Smart infrastructure	Smart technology	Smart healthcare	Smart citizen	Smart governance	Smart energy
Dimensions	Management and organization								
	Technology								
	Governance								
	Institutional Context								
	Community Orientation								
	Economy and Financing								
	Data and Analytics								
	Sustainability								

Dimensions include management and organization, technology, governance, institutional context, community orientation, economy and financing, data and analytics, and sustainability. Application areas, on the other hand, include smart building, mobility, infrastructure, technology, healthcare, citizen, governance and energy. Management and organization refers to managerial and organization factors (Chourabi et al., 2012) including managerial challenges like alignment of organizational goals, conflicting roles, resistance to change as well as managerial strategies like project team skills, clear and realistic goals, planning, roadmapping, good communication (Gil-Garcia and Pardo, 2005). Technology refers to integrated hardware, software and network technologies and provision of real-time and advanced analytics for smart decisions and processes (Washburn et al., 2010). ICTs are the most critical part in smart city applications (Chourabi et al., 2012). Main challenges include IT skills, training, lack of departmental coordination and ambiguous vision of IT among practitioners (Ebrahim and Irani, 2005). Governance refers to stakeholder relationship through which a participatory model is adopted. Cooperation between stakeholders, leadership, alliance structure and jurisdictional differences compose the main pillars of governance (Scholl et al., 2009). Satisfying different needs and expectation of different stakeholders is the key to success in smart city projects. This can only be achieved through participation and cooperation (Meijer and Bolivar, 2016; Palomo-Navarro and Navío-Marco, 2017). Therefore, a smart governance structure where a transparent, accountable and responsive infrastructure is formed is indispensable in smart city projects (Mooij, 2003; Johnston and Hansen, 2011). Institutional context refers to both formal and informal institutions which can enable or constrain smart city applications. Informal institutions include culture, habits, norms and traditions, whereas formal institutions include laws,

regulations, judicial and bureaucratic environment. Without an enabling legal framework, for example, smart city projects can fail regardless of how well technology-oriented projects are applied. Institutional context provides the underlying framework for smart city initiatives. Without addressing those institutional barriers, smart city projects run the risk of failure. Community orientation refers to educating and developing the community so that they are involved and know how to benefit from smart city transformations. The engagement of the communities involved in smart city initiative is key to success or failure of smart city projects. Being an active user of smart city applications is an important dimension of community orientation (Chourabi et al., 2012). Economy and financing refers to the capacity of smart city projects to improve economic competitiveness and innovativeness of the cities. Helping to create sustainable and integrated urban economies is one of the major aims of smart city initiatives. Developing smart financing methods for smart city projects is also an important aspect of this dimension. For example, value capturing, congestion charging, and high occupancy tolls are widely used smart financing methods for smart mobility projects. Data and analytics refers to the capacity to utilize data-driven solutions to provide more responsive urban services (Barns, 2017). Data has the power to change traditional and bureaucratic ways of service provision for a more collaborative, dynamic and agile ways of delivering urban services. Data integration from different data sources is critical to ensure a coordinated service delivery. Various business intelligence and analysis tools and methods can extract valuable information and knowledge from this integrated data (Khan et al., 2014; Khan et al., 2017). Sustainability refers to the potential of smart city initiatives to foster better management of natural resources, protection of the environment and hence, achieving to create a sustainable and livable city. Usage of technology should be directed towards increasing the sustainability (Chourabi et al., 2012). Neglecting this dimension in smart city projects often results in ineffective and inefficient outcomes.

4. ISTANBUL'S SMART CITY PROJECT

Smart city projects in Istanbul are guided by Turkish Ministry of Development's report on "Strategies and Action Plan for Building Knowledge Society, 2015-2018" (SAP-BKS, 2015). Although Istanbul formally started its smart city project in 2017, previous projects involving smart technologies in various areas helped to facilitate the later transformation. These projects include traffic control center, mobile applications for traffic, parking, public transport etc., smart signaling systems, traffic sensors, messaging communication systems, electronic traffic detection systems. Most of the previous projects addressed the mobility aspect of the application areas due to its critical role in Istanbul. Traffic congestion problem in Istanbul is among the 6th worst in the world according to global Tomtom Traffic Index (2017); therefore, smart city project which started in 2017 mainly addressed traffic and mobility problems. Smart mobility systems are also an integral part of smart cities and can bring sustainable and innovative solutions to growing cities, like Istanbul (REC Sustainable Smart Cities Workshop Report, 2017). According to Smart City Roadmap Report (2016) specifically prepared for Turkey by one of the biggest GSM operators in Turkey and an international accounting, auditing and consulting company; urban mobility is the area having the most of the smart city investments (94.7%). Other areas include water management (42.1%), security (31.6%), waste management (31.6%), municipal government services (21.1%) and other urban services (10.5%) as shown in Figure 1.

Figure following on the next page

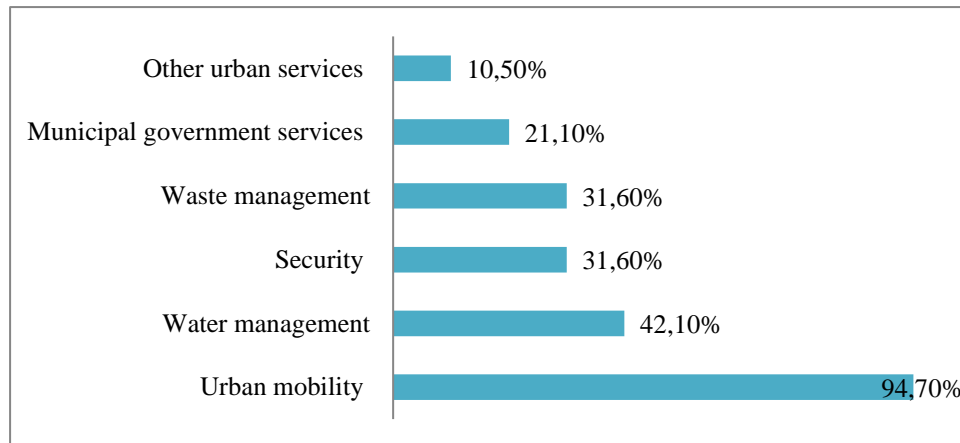

Figure 1: Application areas for smart city investments in Turkey

Although the survey carried out in the report include the responses from 19 metropolitan municipalities in Turkey, it also reflects the situation in Istanbul regarding smart city. Inadequacy of urban mobility services, traffic congestion and parking problems are the main issues expected to be addressed by smart city projects by the citizens of those cities. The smart city applications which are regarded as successful by the respondents mainly include urban mobility area: smart bus stops, smart buses, smart traffic lights and signaling, smart junctions, bike sharing, traffic monitoring, free wi-fi points and communication panels. The report highlights important findings regarding the maturity of smart city in Turkey. It found out that there is a high level of awareness regarding smart city concept and a need for holistic frameworks. The concept is regarded as an opportunity and an urgent need for cities. Also, technology is regarded as the most critical dimension in smart city applications. Smart city concept in Istanbul is mainly defined through a technology - oriented perspective by the CEO of the municipal company responsible for coordinating smart city project. He defines smart city as “the technology supported systems for delivering sustainable and livable cities in every aspect of urban life”. The application areas include governance, economy, mobility, environment, energy, security, people and living. The main aims of the smart city project include the followings (<http://www.fortuneturkey.com/>):

- Facilitating access to urban services,
- Supporting entrepreneurs to develop and commercialize their ideas via incubator centers,
- Providing faster and more comfortable door-to-door urban mobility services,
- Promoting use of alternative energy resources and reducing carbon footprint,
- Promoting efficient use of resources for urban economic growth,
- Providing healthcare to old and disabled people with high quality smart healthcare services,
- Offering real-time data through open data platforms to developers, citizens and researchers,
- Increasing the mobility and social inclusion of disabled people,

Smart city project in Istanbul is composed of 8 phases and planned to complete in 2018. Strategies for technology-supported smart city transformation in Istanbul are stated in Big Smart Istanbul Vision (2016). In order to put forward the strategies, key performance indicators (KPIs) and the roadmap, benchmarking studies with 9 cities have been carried out, which include many global cities around the world: New York, San Francisco, London, Barcelona, Copenhagen, Seoul, Singapore, Berlin and Paris. The main strategies include (i) the transformation of infrastructure and operations by connecting systems, data and people from different municipal departments to offer accessible information and affordable services, (ii) providing real-time communication through mobile applications, devices and interactive platforms to ensuring the engagement of citizens and businesses, (iii) fostering innovativeness

and competitiveness of the local economy by enhancing the entrepreneurial skills of the young workforce. The activities set out in the smart city project mainly include the followings:

- Building smart city system architecture incorporating city strategies, business capacities, business services, application architecture, data architecture and infrastructure architecture,
- Establishing a City Management Center to collect, analyze and manage the big data generated from all data sources and offering open-data platforms,
- Building Living Labs for ensuring the engagement of the community and citizens,
- Regarding urban mobility; offering bike sharing platforms (stations and bicycles), iTaksi mobile application (online taxi management platform), IBB Navi mobile application (online real-time navigation platform), vehicle-to-vehicle and vehicle-to-infrastructure communication systems, transport demand management solutions such as congestion charging and high-occupancy vehicle lanes,
- Focusing on technology-oriented projects: cloud and hybrid cloud technologies, storage, analysis and processing of big data, business intelligence and decision support systems, Internet of Things (IoT) and Machine-to-Machine (M2M) technologies, cyber security including Network Operations Center (NOC) and Security Operations Center (SOC), mobile communication technologies (5G), augmented and virtual reality applications, wearable technologies, deep learning and artificial intelligence systems.
- For energy dimension; distant reading electric meter data, smart city lighting, smart energy demand management, solar power plants.

With the information about the smart city project in Istanbul obtained from semi-structured interviews with project coordinators as well as from press releases, we can now assess the smart city project in Istanbul by using the Smart City integrated assessment framework that we developed. Figure 2 presents the heatmap illustration for the scores of Istanbul's smart city project for each dimension and application areas.

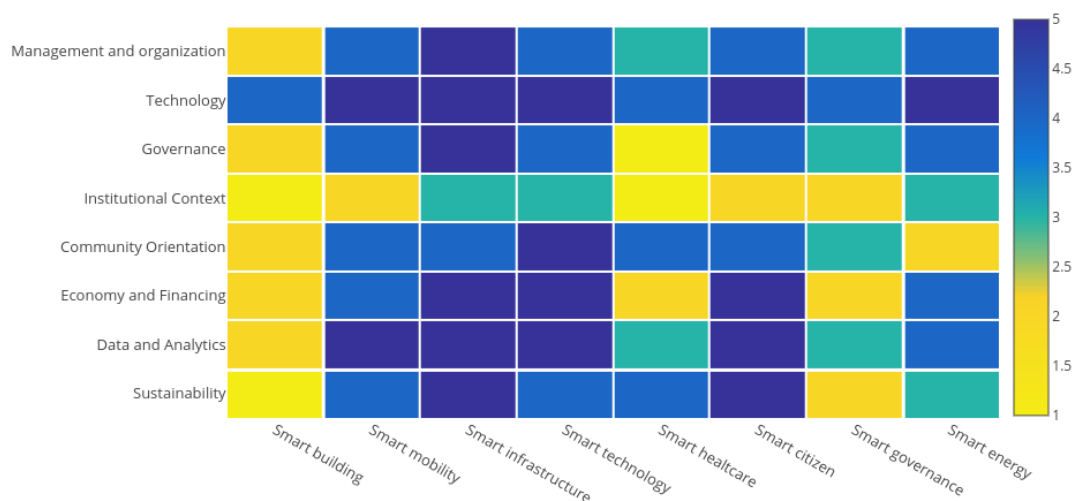

Figure 2: Heatmap for the scores of dimensions and application areas

5. RESULTS AND DISCUSSION

The proposed assessment framework provides a holistic perspective to evaluate the potential areas for improvement in smart city projects. Conflating the dimensions and the application areas, the framework is useful to pinpoint which dimensions need to be worked out in which application areas. Heatmap illustration facilitates this process. When we look at Figure 2, Istanbul's smart city project, overall, has a fairly acceptable level of maturity in many dimensions. The dimension which is addressed most in the project seems to be "technology".

The main coordinator being a technology provider subsidiary municipal company and partner companies being also technology companies explain this higher score for technology. Although technology is an integral part of smart city projects, focusing exclusively on technology aspect can diminish the effectiveness of smart city projects. Techno-centric view of smart city projects can overshadow other important aspects such as governance, community orientation etc. Projects can fail to address people's needs if they are carried out just for the sake of technology itself. "Data and analytics" is another dimension having relatively higher scores. Establishing a City Management Center to collect, analyze and manage the big data generated from all data sources, offering open-data platforms and clear focus on the importance of data increase the score for this dimension. On the other hand, "institutional context" seems to be not addressed adequately. This can hinder the development of project because failing to address the legislation, regulations and broader bureaucratic environment can impact the project outcomes negatively. There is not enough evidence that the smart city project of Istanbul includes the issues and challenges that institutional context brings about. For example, metropolitan municipalities law (numbered 5216) defines the role of metropolitan governments. Without addressing the articles in this law, the application process can be hampered. This is especially important from the "management and organization" and "governance" dimensions since these dimensions refers to alignment of organizational goals, conflicting roles between agencies and stakeholder relationships. The project having a specified project coordinating agency improves the score of management and organization dimension. However, the scores can vary according to application areas. For example, smart building area has low scores in both dimensions because the role of major agencies having a stake in this area like Environment and Urban Ministry and district municipalities are not specified clearly in the project. This can later lead to conflicting roles and misalignment of organizational goals. The project underlines the importance of "sustainability" dimension in its strategies and vision. This is why the scores for this dimension are generally high, except some application areas like smart building, governance and energy. Focusing on how sustainability will be improved in those areas can increase the score of this dimension. On the other hand, supporting local economy and increasing the competitiveness and innovativeness of businesses increase the scores for "economy and financing" dimension. Although economy dimension is well addressed, financing dimension seems to be overlooked. Finding smart financing mechanisms to ensure the financial sustainability of the smart city transformation is an area for improvement. The engagement of the community in the smart city transformation process is well-addressed in the project. Living Labs for example are planned to be established with a view to increasing the engagement of citizens. In terms of application areas, the greatest focus is clearly on smart mobility area. This is understandable given the urgent problems and challenges the city faces in this area. Most of the projects try to bring about a smart solution to traffic congestion, public transport and other urban mobility issues. Therefore, the highest scores are in the intersection of technology dimension and smart mobility area. In contrast, the lowest scores are in the area of smart building and smart healthcare. Smart buildings get very low attention in the project. Furthermore, other than the project regarding providing healthcare to old and disabled people, there is not any mention of other healthcare related projects. Partnership and collaboration with different stakeholders, especially with private sector and non-governmental organizations, in providing smart healthcare can increase the scores in this application area. High numbers of infrastructural projects like building a system architecture increases the scores. The tools of engagement and empowerment for the citizens are considered, yet there is a potential for increase in this area by promoting more participatory channels, customized for different citizen segments. In smart energy area, the focus on technology dimension should also extend to other dimensions to increase the scores for this area.

6. CONCLUSION

In this study, we developed an assessment framework for smart city projects, which includes both dimension and application areas. Istanbul's smart city project is used as a case study to show how the framework can be used. The results show that in terms of dimension, technology plays a very important role which can be explained by the coordinator agency being a technology provider municipal company and partners being global and local technology companies. The techno-centric view is underlined as a risk to be taken into account. In application areas, smart mobility is at the center of the most projects, as the transport problems in Istanbul are quite urgent and needs immediate actions from the local government. Overall, Istanbul's smart city transformation can be regarded as a comprehensive smart city project including most dimensions and areas of smart city concept. There needs to be more focus on institutional context and governance dimensions as well as smart building and energy areas. The main limitation of our study is the limited data and information that we obtained through published materials and semi-structured interviews with experts and practitioners of the project. Sharing of project phase's outcomes and results in a transparent manner would alleviate this limitation. The proposed framework can be further developed by determining the weight factors for dimensions via multi-criteria decision-making methods, which we plan to study in the future. This framework can also be adapted to different settings and contexts and can be utilized in other smart city projects.

LITERATURE:

1. Aina, Y. A. (2017). *Achieving smart sustainable cities with GeoICT support: The Saudi evolving smart cities*. *Cities*, 71, 49-58.
2. Alawadhi, S., Aldama-Nalda, A., Chourabi, H., Gil-García, J., Leung, S., Mellouli, S., ... & Walker, S. (2012). *Building understanding of smart city initiatives*. *Electronic government*, 40-53.
3. Albino, V., Berardi, U., & Dangelico, R. M. (2015). *Smart cities: Definitions, dimensions, performance, and initiatives*. *Journal of Urban Technology*, 22(1), 3-21.
4. Angelidou, M. (2014). *Smart city policies: A spatial approach*. *Cities*, 41, S3-S11.
5. Anthopoulos, L. G., Janssen, M., & Weerakkody, V. (2015, May). *Comparing Smart Cities with different modeling approaches*. In *Proceedings of the 24th International Conference on World Wide Web* (pp. 525-528). ACM.
6. Anthopoulos, L., & Giannakidis, G. (2016). *Policy Making in Smart Cities: Standardizing City's Energy Efficiency with Task-Based Modelling*. *Journal of ICT Standardization*, 4(2), 111-146.
7. Barns, S. (2017). *Smart cities and urban data platforms: Designing interfaces for smart governance*. *City, Culture and Society*.
8. Battarra, R., Gargiulo, C., Pappalardo, G., Boiano, D. A., & Oliva, J. S. (2016). *Planning in the era of information and communication technologies. Discussing the "label: Smart" in South-European cities with environmental and socio-economic challenges*. *Cities*, 59, 1-7.
9. Batty, M. (2013). *Big data, smart cities and city planning*. *Dialogues in Human Geography*, 3(3), 274-279.
10. Bifulco, F., Tregua, M., Amitrano, C. C., & D'Auria, A. (2016). *ICT and sustainability in smart cities management*. *International Journal of Public Sector Management*, 29(2), 132-147.
11. Big Smart Istanbul Vision (2016)< <https://www.slideshare.net/sitecmy/istanbuls-big-smart-roadmap>>

12. Breuer, J., Walravens, N., & Ballon, P. (2014). *Beyond defining the smart city. Meeting top-down and bottom-up approaches in the middle*. Tema. Journal of Land Use, Mobility and Environment.
13. Caragliu, A., Del Bo, C., & Nijkamp, P. (2011). *Smart cities in Europe*. Journal of urban technology, 18(2), 65-82.
14. Chourabi, H., Nam, T., Walker, S., Gil-Garcia, J. R., Mellouli, S., Nahon, K., ... & Scholl, H. J. (2012, January). *Understanding smart cities: An integrative framework*. In System Science (HICSS), 2012 45th Hawaii International Conference on (pp. 2289-2297). IEEE.
15. Cocchia, A. (2014). *Smart and digital city: A systematic literature review*. In Smart city (pp. 13-43). Springer International Publishing.
16. Deakin, M., & Al Waer, H. (2011). *From intelligent to smart cities*. Intelligent Buildings International, 3(3), 140-152.
17. Dirks, S., & Keeling, M. (2009). *A vision of smarter cities: How cities can lead the way into a prosperous and sustainable future*. IBM Institute for business Value, 8.
18. Ebrahim, Z., & Irani, Z. (2005). *E-government adoption: architecture and barriers*. Business process management journal, 11(5), 589-611.
19. Giffinger, R., Fertner, C., Kramar, H., Kalasek, R., Pichler-Milanovic, N., & Meijers, E. (2007). *Smart cities. Ranking of European medium-sized cities*, Final Report, Centre of Regional Science, Vienna UT.
20. Gil-García, J. R., & Pardo, T. A. (2005). *E-government success factors: Mapping practical tools to theoretical foundations*. Government information quarterly, 22(2), 187-216.
21. Hall, R. E., Bowerman, B., Braverman, J., Taylor, J., Todosow, H., & Von Wimmersperg, U. (2000). *The vision of a smart city* (No. BNL--67902; 04042). Brookhaven National Lab., Upton, NY (US).
22. Hollands, R. G. (2008). *Will the real smart city please stand up? Intelligent, progressive or entrepreneurial?*. City, 12(3), 303-320.
23. <http://www.fortuneturkey.com/akilli-sehirler-icin-akilli-gelecek-tasarimi-44346#popup>
24. Jin, J., Gubbi, J., Marusic, S., & Palaniswami, M. (2014). *An information framework for creating a smart city through internet of things*. IEEE Internet of Things Journal, 1(2), 112-121.
25. John, B., Keeler, L. W., Wiek, A., & Lang, D. J. (2015). *How much sustainability substance is in urban visions?—An analysis of visioning projects in urban planning*. Cities, 48, 86-98.
26. Johnston, E. W., & Hansen, D. L. (2011). *Design lessons for smart governance infrastructures. Transforming American governance: Rebooting the public square*, 197-212.
27. Khan, Z., Kiani, S. L., & Soomro, K. (2014). *A framework for cloud-based context-aware information services for citizens in smart cities*. Journal of Cloud Computing, 3(1), 14.
28. Khan, Z., Pervez, Z., & Abbasi, A. G. (2017). *Towards a secure service provisioning framework in a Smart city environment*. Future Generation Computer Systems, 77, 112-135.
29. Kim, T. H., Ramos, C., & Mohammed, S. (2017). *Smart city and IoT*.
30. Kitchin, R. (2014). *The real-time city? Big data and smart urbanism*. GeoJournal, 79(1), 1-14.
31. Lacinák, M., & Ristvej, J. (2017). *Smart City, Safety and Security*. Procedia engineering, 192, 522-527.
32. Lee, J. H., Hancock, M. G., & Hu, M. C. (2014). *Towards an effective framework for building smart cities: Lessons from Seoul and San Francisco*. Technological Forecasting and Social Change, 89, 80-99.

33. Meijer, A., & Bolívar, M. P. R. (2016). *Governing the smart city: a review of the literature on smart urban governance*. *International Review of Administrative Sciences*, 82(2), 392-408.
34. Mooij, J. E. (2003). *Smart Governance?: Politics in the Policy Process in Andhra Pradesh, India*. London: Overseas Development Institute.
35. Mora, L., Bolici, R., & Deakin, M. (2017). *The First Two Decades of Smart-City Research: A Bibliometric Analysis*. *Journal of Urban Technology*, 1-25.
36. Morvaj, B., Lugaric, L., & Krajcar, S. (2011, July). *Demonstrating smart buildings and smart grid features in a smart energy city*. In *Energetics (IYCE), Proceedings of the 2011 3rd International Youth Conference on* (pp. 1-8). IEEE.
37. Mulligan, C. E., & Olsson, M. (2013). *Architectural implications of smart city business models: An evolutionary perspective*. *IEEE Communications Magazine*, 51(6), 80-85.
38. Nam, T., & Pardo, T. A. (2011, June). *Conceptualizing smart city with dimensions of technology, people, and institutions*. In *Proceedings of the 12th annual international digital government research conference: digital government innovation in challenging times* (pp. 282-291). ACM.
39. Nam, T., & Pardo, T. A. (2011, September). *Smart city as urban innovation: Focusing on management, policy, and context*. In *Proceedings of the 5th international conference on theory and practice of electronic governance* (pp. 185-194). ACM.
40. Nations, U. (2014). *World Urbanization Prospects: The 2014 Revision, Highlights*. Department of Economic and Social Affairs. Population Division, United Nations.
41. Neirotti, P., De Marco, A., Cagliano, A. C., Mangano, G., & Scorrano, F. (2014). *Current trends in Smart City initiatives: Some stylised facts*. *Cities*, 38, 25-36.
42. Niaros, V. (2016). *Introducing a taxonomy of the “smart city”: Towards a commons-oriented approach?. tripleC: Communication, Capitalism & Critique*. *Open Access Journal for a Global Sustainable Information Society*, 14(1), 51-61.
43. Niaros, V., Kostakis, V., & Drechsler, W. (2017). *Making (in) the smart city: The emergence of makerspaces*. *Telematics and Informatics*.
44. Palomo-Navarro, Á., & Navío-Marco, J. (2017). *Smart city networks' governance: The Spanish smart city network case study*. *Telecommunications Policy*.
45. Prado, A. L., Da Costa, E. M., Furlani, T. Z., & Yigitcanlar, T. (2016). *Smartness that matters: towards a comprehensive and human-centred characterisation of smart cities*. *Journal of Open Innovation: Technology, Market, and Complexity*, 2(1), 1-13.
46. REC Sustainable Smart Cities Workshop Report, 2017
<https://recturkey.files.wordpress.com/2017/08/surdurulebilirakillisehirlercalistayi_kitapik_vf.pdf>
47. Roche, S. (2014). *Geographic Information Science I: Why does a smart city need to be spatially enabled?. Progress in Human Geography*, 38(5), 703-711.
48. SAP-BKS, (Strategies and Action Plan for Building Knowledge Society, 2015-2018) (2015), Turkish Ministry of Development,
<<http://www.akillisehirler.org/wp-content/uploads/2016/08/2015-2018-Bilgi-Toplumu-Stratejisi-ve-Eylem-Plani.pdf>>
49. Sarma, S., & Sunny, S. A. *Civic Entrepreneurial Ecosystems: Smart City Emergence in Kansas City*, *Business Horizons*, 2016. // APA düzelt
50. Scholl, H. J., Barzilay-Nahon, K., Ann, J. H., Popova, O. H., & Re, B. (2009, January). *E-Commerce and e-Government: How do they Compare? what can they Learn from each Other?. In System Sciences, 2009. HICSS'09. 42nd Hawaii International Conference on* (pp. 1-10). IEEE.
51. Seta, F., Sen, J., Biswas, A., & Khare, A. (2015). *From Poverty, Inequality to Smart City*. In *Proceedings of the National Conference on Sustainable Built Environment*.

52. Tomtom Traffic Index (2017), < https://www.tomtom.com/en_gb/trafficindex/ >
53. Vanolo, A. (2014). *Smartmentality: The smart city as disciplinary strategy*. *Urban Studies*, 51(5), 883-898.
54. Villa, N., & Mitchell, S. (2009). *Connecting cities: achieving sustainability through innovation*. In Fifth Urban Research Symposium.
55. Washburn, D., Sindhu, U., Balaouras, S., Dines, R. A., Hayes, N., & Nelson, L. E. (2009). *Helping CIOs understand "smart city" initiatives*. *Growth*, 17(2), 1-17.
56. Zygiaris, S. (2013). *Smart city reference model: Assisting planners to conceptualize the building of smart city innovation ecosystems*. *Journal of the Knowledge Economy*, 4(2), 217-231.

PROSTITUTION IN THE REPUBLIC OF CROATIA

Dasa Panjakovic Senjic

*Joint law office Krešimir Panjaković and Daša Panjaković Senjić
Kapucinska 27/2, 31 000 Osijek
odvjetnik.panjakovic@inet.hr*

ABSTRACT

Trafficking in human beings is one of the biggest problems of today, and it is noted that it is the third in the ranking of global problems, immediately after the trade of illegal drugs and arms trade. Trafficking in human beings is the criminal activity most commonly manifested through the sexual exploitation of younger women. Victims of prostitution and other forms of trafficking in human beings have often been brought into the world by various deceptions through promises of better life, great work and earnings. Victims agree to something that is in a state of bad material existence that makes them great and they are not even aware of what is waiting for them. They are constantly subjected to violence, intimidation, depriving them of all documents, limiting their freedom of movement, and becoming slave slaves, or the whole system of crime.

Keywords: *human trafficking, prostitution*

1. INTRODUCTION

You can often hear that prostitution is referred to as the oldest profession, especially due to the fact that it exists from the very beginning of the development of society. Speaking of prostitution, it is important to point out that it has been the issue of numerous studies, especially today, when it is the major problem which is destroying the society in general. Namely, the point is that the very phenomenon reached such a point that causes a variety of diseases, mental and physical disorders, disorders in society like corruption and crime itself. The prostitution represents only one form of human trafficking. In general, it is the slavery of people, that suffer the most women and children for reasons of unemployment, poverty, unsettled lives, different forms of discrimination in society and so on. The victims are promised a better life, a better job and a great salary. However, therefore after their consent the agony begins from which hardly anyone ever manages to get out. The victims become the property of pimps and organizations involved in trafficking people, they are deprived of all their documents and all personal belongings, they have to do everything they are made to do in order to survive. They enter the world of drugs and crime. Croatia is very well acquainted with the problem of prostitution and trafficking in general with people, and daily records many victims of these phenomena. In cooperation with the Ministry of the Interior and other institutions that seek to deal with this issue and finally release the society of the same. It is a large issue that has not yet been found of adequately solution, but we must not give up. You should constantly warn citizens on this issue and seek their cooperation in the prevention of these phenomena.

2. HISTORY OF THE EXISTENCE OF PROSTITUTION

The prostitution has existed since the very beginning of the development of society. Although the historical sources of prostitution scarce and they are less accessible, numerous scientists and experts are trying to study and explain its origins until the present. In addition to the fact that prostitution is one of the oldest forms of deviant behavior, it is also represented as the social, moral, health and society problem. The most common interpretation of the term prostitution refers to the behavior, when some people give their bodies to other people to enjoy the material benefits. With the advent of civil society, migration to the cities and greater mobility of the population, prostitution has become massive, which caused a number of problems, particularly those of legal, medical and social issues.

The prostitution is therefore soon linked with crime and other deviant behaviors¹. In addition, associated with health problems, especially with the spread of tuberculosis and sexually transmitted diseases. The civil society itself has already tried to solve the problem of prostitution or at least to mitigate its consequences. Therefore, there has always been the need to monitor the prostitution. Europe had to act so in the 19th century so they had to legally regulate the prostitution. Thus, the state through its legislation restricted mainly to the regulations on brothels or on special regulations and supervision obligations that the prostitutes had to do. In fact, it was the regulation of the prostitution. Adopted legislative measures have largely been unsuccessful in the intentions of control, especially because illegal prostitution existed at the same time during the legal prostitution. Very soon arose an abolitionist movement that advocated a ban on all public houses, as well as any form of legalization of prostitution. Most European countries in the late 19th and in the first half of the 20th century abolished regimentation and introduced some of the models of possible abolitions of prostitution. Especially, Scandinavian countries: Sweden, Norway and Denmark were the pioneers in that field². In Croatia, the problem of prostitution in Zagreb can be traced in two periods: until 1934 (when the prostitution was legal and regimented; prostitution in brothels or place of debauchery and later publicly tolerated prostitutes)³ and from 1934 (when every form of prostitution was prohibited by the Law on combating sexually transmitted diseases)⁴.

3. PROSTITUTION AS A FORM OF TRAFFICKING IN HUMAN BEINGS

Trafficking in human beings is business, that is a crime that is present throughout the world, and is constantly growing. Trafficking in human beings always involves movement from poorer countries to richer ones, its size and importance requiring rapid response and little room for mistakes (especially because the fate of millions of women and children, as well as men, is in danger). Unavoidable is the fact that trafficking in persons is more profitable than drug trafficking and weapons because the human body can be sold numerous times⁵.

3.1. Defining the concept of trafficking in human beings

UN has a formal definition of the term human trafficking, and exactly what trafficking includes: trafficking in human beings also means the recruitment and / or transportation, transfer, harboring or receipt of persons by force or threat or other forms of coercion, abduction, fraud, deception, abuse of authority or the position of supervisor, fraud or other forms of coercion for the purpose of sexual or economic exploitation in order to obtain profits in favor of a third person and / or group (pimp, pimps, traffickers, intermediaries). According to the Ministry of the Interior in the Republic of Croatia, trafficking refers to any action involving the recruitment, transportation within or outside the country, purchase, sale, transfer, receipt or provision of shelter to a person on the basis of fraud, coercion, including threats of violence, abuse of power to people held in involuntary situations regardless of salary, in the household, in forced labor or slave-like conditions and in the community beyond those in which the person lived when fraud or coercion occurred. Definitions of trafficking show a violation of basic human rights, as evidenced by the degrading conditions in which such work is carried out. An important fact is that the victim of trafficking moves to an unfamiliar environment which is isolated from its immediate community and exposed to abuse, violence and exploitation,

¹ Zorko, Tomislav: Women prostitution between 1899 and 1934, *Magazine for contemporary history*, Vol. 38, No. 1, 2006., p. 223.-224.

² *Ibid.*, p. 224.

³ In 1922 the public houses were banned, and the girls and women doing prostitution were considered as public tolerant prostitutes and they had to be recorded in the special record book.

⁴ Zorko, Tomislav, *op. cit.*, p. 225.

⁵ Belušić, Morana et al.: Human Beings Trafficking, *Kriminologija i socijalna integracija*, Vol. 14, No. 2, 2006., p. 51.

domination and discrimination against people traffickers⁶. Trafficking represents part of the new terminology in presenting problems servitude people would simplest definition of this term was trafficking in person especially women and children, trafficking in human misery, and represents one of the biggest crimes nowadays. Until recently, there was not even universally accepted definition of human trafficking, but the organizations working to combat the problem were used different definitions. This trafficking can be defined in the following way: Trafficking in human beings is a criminal form of commercial trafficking in human beings who are subjected to do actions without personal consent, such as begging, prostitution (eg. prostitution or arranged marriage), compulsory labor (ie. slave labor in various factories). Human trafficking involves the process of using physical force, fraud, abuse, deception and other forms of coercion and intimidation for the purpose of purchasing, recruitment, placement and transport people⁷.

4. PROSTITUTION IN CROATIA

EU through its projects and programs IPA seek to strengthen the capacities of participants in the fight against human trafficking and to investigate the relationship between forced prostitution, labor and human trafficking. Given that the rate of human trafficking in Croatia is considerably high, shall be deposited with high hopes that the project will enable better detection of criminals and their victims. The project will be implemented by the Office for Human Rights and National Minorities and the Romanian National Agency against Trafficking in Persons. Trafficking in human beings is one of the most vicious examples of human rights violations and is recognized as a growing problem in the fight against international organized crime. Targeted are often women and girls trafficked for sexual exploitation, but a significant part of that trade relations and labor exploitation⁸. Prostitution has always been a lucrative business, however, entails a number of negative consequences due to the efforts of people to come to material existence. The main motive for the prostitution is so-called trade. white slavery, which actually represents the part of modern slavery. The UN estimates that 79% of trafficking is only prostitution. The Article 106 of the Criminal Justice Act of the Republic of Croatia for trafficking states: "Whoever, by force or threat, deceit, fraud, kidnapping, abuse of power or of a position or relationship addiction, giving or receiving money fees or other benefits to achieve the consent of a person having control over another person, or in any other way recruits, transports, transfers, harbors or receives a person or exchanges or transfers control of the person to take advantage of her work through forced labor or servitude, forced slavery or other similar relationship, or because of its prostitution abuse or other forms of sexual abuse including pornography or not allowed or forcibly marriage, or because of taking one part of her body or because of armed conflict or because of illegal acts, will be sentenced between one and ten years in prison"⁹. The Republic of Croatia is aware of the fact that one of important conditions for successful fight against trafficking and for helping and protection of victims. Not only the mentioned Criminal Justice Act but also following Acts follow the issue of prostitution:

- Law on liability of legal persons for criminal offenses,
- Law on Office for Suppression of Corruption and Organized Crime
- Law on Juvenile courts

⁶ *Ibid.*, str. 51.-52.

⁷ Doležal, Dalibor: Prevention of Human Beings Trafficking, *Zbornik Pravnog fakulteta Sveučilišta u Rijeci*, Vol. 28, No. 2, 2007., p. 1400.-1401.

⁸ In Croatia from 2002 till 2012 there are registered 116 victims of human beings trafficking, that were mostly victims of sexual and labour abuse. Victims from foreign countries in the last four year were mostly citizens from Bosnia and Herzegovina, Serbia, Romania, Bulgaria and Moldavia. In 2012 there were 11 people recorded as victims of human beings trafficking in Croatia. During 2008, 2009 and 2010 in the Republic of Croatia is recorded in the group of countries that has made much effort in reducing human beings trafficking, prevention of trafficking, victims protection and prevention of it..

⁹ Criminal Justice Act (*Narodne novine* br. 125/11, 144/12).

- Act of responsibility of legal persons for criminal offenses
- Witness Protection Law,
- The Law on Foreigners,
- Law on Prevention of Money Laundering,
- Act on Mutual Legal Assistance in Criminal Matters
- Law on Asylum and
- Law on compensation for victims of work (effective entry into the EU).

4.1. Activities of the Republic of Croatia in combating human trafficking

The Republic of Croatia in combating the human trafficking through the Croatian National Strategy for combating trafficking in persons shows its active engagement in combating organized crime of an international character. In 2002 it was established the National Committee for Combating Trafficking in Persons in order to build a comprehensive system of combating trafficking in persons in the Republic of Croatia. Thereafter, adopts the National Plan to Combat Trafficking in Persons of 2002, the National Program for Combating Trafficking in Persons from 2005 till 2008 with the associated operational plans, the National Plan to Combat Trafficking in Children from 2005 to 2007 and the National Plan for Combating Trafficking in Persons for the period 2009 to 2011. After a long fight against trafficking in persons in the Republic of Croatia, it was established a complete system that includes activities from the moment of identification of victims of trafficking until they are fully integrated, and reintegration into society. Within the system for combating human trafficking cooperation has been established between the competent government bodies, civil society organizations and non-governmental organizations. It was noted that Croatia is becoming more countries of origin and final destination for victims of trafficking, especially for victims of the South East Europe. Also, although most of the victims are still women and girls, noticed an increase of men as victims of trafficking for the purpose of labor exploitation. The above trends competent institutions have responded to the action on the field more effectively identify victims of trafficking. Due to the above, the drafting of the new National Plan to Combat Trafficking in Persons for the period from 2012 to 2015. The new plan covers all areas of previous national documents dealing with the topic of combating trafficking in persons and the proposed measures and activities built into the experience of all relevant government bodies, civil society organizations, non-governmental and international organizations. New plan pays special attention to further strengthening cooperation in criminal proceedings in cases of trafficking between the State Attorney's Office and the Ministry of Interior, improving methods of identifying victims of trafficking and ensuring the best interests of victims of trafficking¹⁰. Activities Ministry of Interior in combating trafficking in persons and consist of the following tasks: in all police departments in the Republic of Croatia are determined by the law enforcement officers involved in combating trafficking in human beings and that, in each case, directly participate in the identification of victims and the perpetrators of this form of organized crime; in all cases when the victim of trafficking a child or a minor for the purpose of initiating urgent help and protection, are engaged and police officers for juvenile delinquency. In addition to these police officers of the criminal police, according to a special program conducted training for police officers of the border police, who actively participate in the discovery of these crimes, or victims of trafficking and their safe return, when it comes to foreign nationals¹¹.

¹⁰ The area that the new National plan for Combating Trafficking in Human Beings for the period 2012 till 2015 combines: normative framework; identification of victims of trafficking; detection, prosecution and punishing of perpetrators of the crime of trafficking in human beings; help and protection of the victims of human being trafficking; trgovanja ljudima; prevention; education; international cooperation; coordination of activities.

¹¹ In order to develop international cooperation The Ministry of Interior has international police cooperation with INTERPOL, EUROPOL and SELEC Centers through team groups for prevention of human beings trafficking. The main aim is the most efficient information exchange, as well as police cooperation on the international and regional level.

5. CONCLUSION

Trafficking in human beings is a phenomenon which has existed since the humanity, and is one of the worst forms of human rights violations. One problem lies in the legislation of different countries. A number of countries have only recently included trafficking in its legislative framework and defined it as a criminal offense. This is due to problems such as high corruption in poor countries, and refers people to the problem of human trafficking. The victim of prostitution (and generally trafficking in human beings) actually loses its identity, and thus control over their lives. It should be noted that this phenomenon particularly affects women. However, trafficking in human beings most often realized in the form of forced prostitution. Prostitution becomes problematic activity even in liberal countries that have legalized prostitution. Women who are in prostitution only are there because of coercion by pimps or difficult social situation. Both situations constitute coercion or form of violence. Of course, there is the small number of persons who are engaged in prostitution from the pleasure of fetishes. Prostitution on the victims left many physical and psychological consequences, which usually last a lifetime. An essential prerequisite for prostitution and trafficking in women are sexual appetites of men focused particularly on women, young girls and children. From prostitution benefit exclusively traffickers and pimps on the economic, social, political and legal subordination and dependence of women and girls. Due to the fact that unfortunately, very difficult to control prostitution (in countries that have legalized prostitution) or trafficking that there is booming and girls are prepared false documents with false dates of birth to traders manipulated the age. Croatia shows how it goes in the right direction to improve the prevention of trafficking, toiling many programs and projects to improve the current situation. Also, many countries in Europe and the world is trafficking in human beings is recognized as a major social problem that needs to be eradicated. In Croatia and other countries in Europe and worldwide quest to constantly strive to develop a high level of legal protection for victims as well as the cooperation of all involved in human trafficking. Croatia shows how it goes in the right direction to improve the prevention of trafficking, toiling many programs and projects to improve the current situation. Also, many countries in Europe and the world is trafficking in human beings is recognized as a major social problem that needs to be eradicated. in Croatia and other countries in Europe and worldwide quest to constantly strive to develop a high level of legal protection for victims as well as the cooperation of all involved in human trafficking. Croatia shows how it goes in the right direction to improve the prevention of trafficking, toiling many programs and projects to improve the current situation. Also, many countries in Europe and the world is trafficking in human beings is recognized as a major social problem that needs to be eradicated. In Croatia and other countries in Europe and worldwide quest to constantly strive to develop a high level of legal protection for victims as well as the cooperation of all involved in human trafficking.

LITERATURE:

1. Belušić, Morana et al.: Trgovanje ljudima, *Kriminologija i socijalna integracija*, Vol. 14, No. 2, 2006., str. 51.-59.
2. Doležal, Dalibor: Prevencija trgovanja ljudima, *Zbornik Pravnog fakulteta Sveučilišta u Rijeci*, Vol. 28, No. 2, 2007., str. 1399.-1420.
3. Kazneni zakon (*Narodne novine* br. 125/11, 144/12).
4. Sandra Veber i Zlatko Koštić: Obilježja trgovanja ljudima u Republici Hrvatskoj, *Policija i sigurnost*, Vol. 20, No. 2, 2011., str. 203.-210.
5. Šime Matak i Ana Vargek: Trgovanje ljudima u svrhu seksualnog iskorištavanja – utječe li legalizacija prostitucije na smanjenje trgovanja ljudima?, *Pravnik*, Vol. 46, No. 92, 2012., str. 59.-80.
6. Trgovanje ljudima – mup.hr (24.04.2013.) <http://www.mup.hr/31.aspx>

7. U Hrvatskoj registrirano 116 žrtava trgovine ljudima (25.04.2012.)
<http://www.rtl.hr/vijesti/novosti/657319/u-hrvatskoj-registrirano-116-zrtava-trgovine-ljudima/>.
8. Zorko, Tomislav: Ženska prostitucija u Zagrebu između 1899. i 1934. godine, *Časopis za suvremenu povijest*, Vol. 38, No. 1, 2006., str. 223.-241.

EXTENDING THE ROLE OF SERVQUAL MODEL IN ISLAMIC BANKS WITH SUBJECTIVE NORMS, CUSTOMER SATISFACTION AND CUSTOMER LOYALTY

Feras M.I. Alnaser

*PhD scholar at Universiti Sultan Zainal Abidin, Terengganu, Malaysia
sunvictory5@gmail.com*

Mazuri Abd Ghani

Senior Lecturer at Universiti Sultan Zainal Abidin, Terengganu, Malaysia

Samar Rahi

*PhD Scholar at Universiti Sultan Zainal Abidin, Terengganu, Malaysia
sr_adroit@yahoo.com*

Majeed Mansour

*Arab American University, Jenin, Palestine
majeeddo@yahoo.com*

Hussein Abed

*An-najah National University, Nablus, Palestine
husseinabed@najah.edu*

Ali Hawas Alharbi

*Technical and Vocational Training Corporation, Saudi Arabia
Aalharbi20@tvtc.gov.sa*

ABSTRACT

In last few decades, service quality has received a great attention from both academic and practitioners. Despite the existing literature on service quality, fewer studies have been conducted on service quality that examine the customer satisfaction and customer loyalty in Palestinian banking sector. This study extended the SERVQUAL model with subjective norms to investigate the customer satisfaction and customer loyalty in Islamic Banks. Structural equation model (SEM) is applied to check the hypotheses relationship between proposed constructs. Finding revealed that the extended model has significant impact on customer satisfaction and customer loyalty in Islamic banks of Palestine. The findings of this study will be helpful for policy makers to improve the service quality in Islamic Banks of Palestine. Furthermore, this study unearths certain areas that were not previously discussed in Arab cultural context such as studying subjective norms.

Keywords: *SERVQUAL, Subjective Norms, Customer Satisfaction, Customer Loyalty, Cultural Context, Structural Equation Modeling (SEM)*

1. INTRODUCTION

Services are increasingly becoming a large portion of any organization and being considered as indispensable tool for revenue stream (S. Samar, Ghani, & Alnaser, 2017). Long-term relationship and customer satisfaction can build by providing high service quality to customers. In banking industry, F. Alnaser, M. Ghani, S. Rahi, M. Mansour, and H. Abed (2017) study explained that strong relationship between banks and customers builds customer loyalty which give competitive advantage to banks. Service quality is defined as the customer expectations and perception of actual service (FMI Alnaser, Ghani, & Rahi, 2017; Parasuraman, Zeithaml,

& Berry, 1985). According to F Alnaser, Ghani, and Rahi (2018) defined service quality as the outcome of the comparison that consumer make between their expectation and perception. In banking industry service quality plays a vital role in improving of customer satisfaction (S Rahi, 2016; S. Rahi & M. Ghani, 2016). The practitioners believe that service quality can increase the performance of a firm (F. M. I. Alnaser, M. A. Ghani, S. Rahi, M. Mansour, & H. Abed, 2017; Grönroos, 1984; Kashif, Abdur Rehman, & Pileliene, 2016; Kyoonyoo & Ah Park, 2007; Rahi Samar, Mazuri Abd Ghani, & ALNASER, 2017; R. Samar, Norjaya, & Feras, 2017). However, service quality and customer satisfaction interchangeable terms (Kyoonyoo & Ah Park, 2007). Previous studies have suggested that service quality is positively associated with customer satisfaction in banking industry of Pakistan (Kashif et al., 2016; R. Samar et al., 2017). Furthermore, considerable amount of work has been done in service industry in order to understand the dimensions of service quality and customer satisfaction (Chumpitaz & Papatoukidis, 2004; Pantouvakis, 2013; S. Rahi & M. A. Ghani, 2016). Therefore, the measurement of service quality has become the most difficult task for organization. Following above arguments this study is measure impact of service quality on customer satisfaction and loyalty in banking context of Palestine. Therefore, three objectives are as follows:

1. To examine the condition of service quality in Islamic Banks of Palestine
2. To analyze factors that led to customer satisfaction in Islamic Banks of Palestine
3. To find mediating role of customer satisfaction between SERVQUAL and customer loyalty

To the best of researcher knowledge, up till now there is no such study that extended the SERVQUAL model with subjective norms. In this study, researcher used the modified model SERVQUAL and extended it with subjective norm in order to measure the customer satisfaction and customer loyalty of Palestinian Islamic banking customers. SERVQUAL model was developed and tested in western culture consequently it cannot measure the service quality issues faced by developing countries (Raajpoot, 2004). Subjective norm is the core factor of theory of reasoned action (TRA) and measure the cultural aspects. Thus, it is believed that to extend SERVQUAL model with subjective norm would be significant and provide a platform to discuss the service quality issues in Islamic banks of Palestine.

2. LITERATURE REVIEW

2.1. Service Quality in Banking

In last few decades, service quality has received a great attention from both academic and practitioners (Rahi, Ghani, Alnaser, & Ngah, 2018). Customer expectation's serves as a foundation of service quality. Additionally, it is assumed that high quality and performance exceeds expectation while low quality performance does not meet the expectation (Samar Rahi, Mazuri Abd. Ghani, & Abdul Hafaz Ngah, 2018). In services marketing SEVEQUAL model has been used widely for measuring of service quality. Several researcher have been used SERVQUAL model for measuring of service quality in banking sector (Kashif et al., 2016; Marković, Jelena, & Katušić, 2015; S. Rahi & M. A. Ghani, 2016; Rahi & Ghani, 2018b; Rahi Samar et al., 2017).

2.2. Servqual

According to Zeithaml, Berry, and Parasuraman (1996) the measurement and achievement of service quality has been advantageous for the firm due to several reasons such as lower cost, customer loyalty and increased market share. Thus, for the measurement of service quality in Islamic banks of Palestine, this study have used the most popularised service quality model; SERVQUAL. The revolutionary SERVQUAL model was developed by Parasuraman et al. (1985). Initially the model was comprised with 10 dimensions, which further reduce to five dimensions.

There are five core dimension of SERVQUAL model, namely tangibility, reliability, assurance, empathy and responsiveness. The key definition of these five dimensions as follows:

1. Tangibility is seen as appearance of physical facilities, equipment, personnel, and communication material (Parasuraman et al., 1985).
2. Reliability is defined as the ability to perform the promised service dependably and accurately (Parasuraman et al., 1985).
3. Assurance is defined as the courtesy of employees and their ability to inspire trust and confidence (Parasuraman et al., 1985).
4. Responsiveness is defined as employee willingness to guide customers and look fully engaged while service is performed (Parasuraman et al., 1985).
5. Empathy is defined as employees pay full attention to customers during service delivery (Parasuraman et al., 1985)

These five dimensions have been used to develop a service quality model named SERVQUAL. Although the SERVQUAL model has been criticised by several researcher but it is still widely used in service marketing (Marković et al., 2015). This scale has been extensively used by service marketing researchers in USA and European countries. In banking context Cai, Zhang, Kumar, and Wyman (2014) have employed SERVQUAL model to investigate service quality of Malaysian banks. Raajpoot (2004) has extended the SERVQUAL model in cultural context and incorporated three dimensions of SERVQUAL model named; tangibility, reliability, and assurance in newly developed PAKSERV model. Several studies has proved significant relationship of SERVQUAL relationship with customer satisfaction and customer loyalty (Kashif et al., 2016; Marković et al., 2015). Keeping these contribution in mind the following hypothesis are proposed:

- H1: Tangibility is significantly influence on customer satisfaction
- H2: Reliability is significantly influence on customer satisfaction
- H3: Assurance is significantly influence on customer satisfaction

2.3. Subjective Norms

Subjective norm is defined as individual perception that refer to group or individual in order to improve or disapprove the given behavior (Fishbein & Ajzen, 1975). Subjective norm deals with the influence of social environment or social pressure towards individual behavioral intention (Fishbein & Ajzen, 1975). Subjective norm has seen as core factor that influence on customer purchase behavior (Ryan & Bonfield, 1975). According to Venkatesh and Davis (2000) social influence or social pressure instigate individual to perform a behavior though the individual is not in favor of performing the behavior. Additionally, subjective norm measure the social influence on customer behavior that is made by under the expectation of family and friends. Previous studies has shown different results in relationship of subjective norm as predictor of intention (F. Alnaser, M. Ghani, & S. Rahi, 2017). Author like Hyllegard, Paff Ogle, Yan, and Attmann (2010) asserted that subjective norms and awareness predict the loyalty intention towards a particular brand. Roca, Chiu, and Martínez (2006) found that there is a significant relationship between subjective norms and perceived service quality. In another study by Parkinson, Russell-Bennett, and Previte (2012) indicated that subjective norm significantly relates with customer loyalty. Hence, the following hypothesis is proposed:

- H4: Subjective norm is significantly influence on customer satisfaction

2.4. Customer Satisfaction

Satisfaction is attributed to a customer's feelings of happiness when his/her expectations met by the service provider (Rahi, Ghani, & Muhamad, 2017). In service management literature customer satisfaction can be defined as being a summary of cognitive and affective reaction to

a service incident or to a long-term service relationship (Lee, Kim, Ko, & Sagas, 2011). According to Ueltschy, Laroche, Zhang, Cho, and Yingwei (2009) customer satisfaction is the response of the customer who evaluate his or her prior expectations and actual performance of the product/service. Globally, customer satisfaction has been considered a powerful intangible asset for competitive advantage (Ueltschy et al., 2009). In other words customer satisfaction or dissatisfaction in services marketing is result of the customer's expectation encounters with a service quality. The customer's life time loyalty with the service offered depends heavily on their satisfaction (Oly Ndubisi, 2007). Service quality has been identified as key strategy for increased level of customer satisfaction (Lee et al., 2011). It is said that both customer satisfaction and service quality perception positively impact the repurchase intention of the customer (Lee et al., 2011; Oliver, 1997). Marković et al. (2015), clarified that service quality influence on customer satisfaction and customer loyalty. Thus, the following hypothesis is proposed:

- H5: Customer satisfaction is significantly influence on customer loyalty

2.5. Customer Loyalty

Service quality is an effective tool to keep customers loyal to the bank. According to Baumann, Elliott, and Hamin (2011), loyalty is an attitude as well as specific behavior. Customer loyalty has been an important element to increase firm profitability (Oliver, 1997). Customer loyalty has been defined as; “a deeply held commitment to re-buy or re-patronize a preferred product consistently in the future situational influences and marketing efforts that might cause switching behavior” (Mazuri, Samar, Norjaya, & Feras, 2017; Oly Ndubisi, 2007). Regardless of the service quality measurement, it is evident that service quality influences customers' perceived value, satisfaction, and loyalty (Marković et al., 2015). The behavioural loyalty reflects customer's positive response to purchase a particular product or service (Amin, Isa, & Fontaine, 2013; Rahi, 2015; Samar Rahi, 2016; S. Rahi & M. A. Ghani, 2016). The customers who are loyal with banks spend much more than other customers (Amin et al., 2013). Several studies confirmed that loyalty in banking sector have attributed as function of customer satisfaction (Amin et al., 2013; Ladhari, Ladhari, & Morales, 2011). Thus, the following theoretical framework is proposed

Figure following on the next page

Figure 1: Theoretical Framework

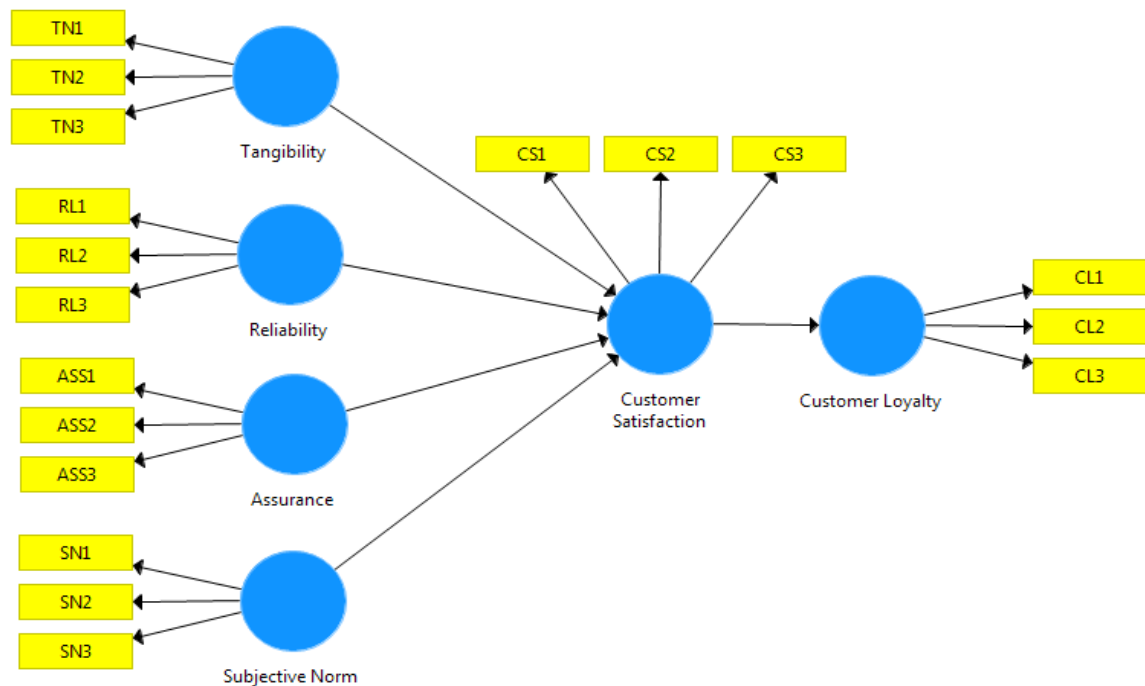

3. METHODOLOGY

The study examined service quality in Islamic banks of Palestine by extending SERVQUAL model with subjective norms and customer satisfaction. Bear in mind the criticism on SERVQUAL model, researcher used the three dimensions of SERVQUAL model as suggested by (Raajpoot, 2004). A survey-based research design employed to achieve the objective of the study.

3.1. Instrument Development

The survey had two parts. The first part comprised on dimensions of SERVQUAL model, subjective norm, customer satisfaction and customer loyalty. The three dimensions of SERVQUAL model had 9 items and adapted from previous developed scale by A. Parasuraman, Zeithaml, and Berry (1988). The subjective norm consisted of 3 items adopted from previous study by Fauziah, Taib, Ramayah, and Abdul Razak (2008). Customer satisfaction consisted of 3 items adapted from Sayani (2015). Lastly, 3 items of customer loyalty adopted from R. Samar et al. (2017). All the items anchored on a 7-point Likert scale “1= strongly disagree to 7 strongly agree” as suggested by R. Samar (2018b). The second part comprised of respondent demographics such as age, gender and education.

3.2. Survey Design and Sampling

The context of the study was Islamic Banks of Palestine. The survey was self-administered for collect the data of Islamic bank customers located in the city of Ramallah, Palestine. Before conducting the survey, researcher took the permission from manager to collect the data inside of bank. Convenience sampling method was used in this study. Convenience sampling defined as a process of data collection from population that is close at hand and easily accessible to researcher (Rahi, 2017). According to J.F. Hair (2003) illustrated that convenience sampling allows researcher to complete interviews or get responses in a cost effective way.

Thus, for data collection researcher personally visited the Arab Islamic Bank and requested to Islamic Bank customers to fill the questionnaire. The required sample size was 500. A set of 600 structured questionnaires were distributed out of 500 useable responses were received from customers of Islamic Banks.

3.3. Respondent's Profile

Table 1 summarised the demographics of the sample selected to achieve the purpose of this study. Males were (52.4%) slightly more than females (47.6%). The age of the respondents 34.0% is for less than 20 years old, 36.4% that counts at age between 21 to 30 years, 19.2% for 31 to 40years and 10.4% respondents aged 41 to 50. Furthermore, Table 1 also depicted that education of the respondents 3.0% respondents were having high school education, 8.2% from those who has diploma, 11.6% respondents who has bachelor degree, 49.4% master level education while there were 27.85 respondents were with PhD degree.

Table 1: Demographic Profile of the Respondents

Demographic Characteristics	Frequency	Percentage (%)
Gender		
Male	262	52.4
Female	238	47.6
Age		
Less than 20 years	170	34.0
21-30 years	182	36.4
31-40 years	96	19.2
41-50	52	10.4
Education		
High School and Below	15	3.0
Diploma	41	8.2
Bachelor	58	11.6
Master	247	49.4
PhD	139	27.8

3.4. Measurement Model

To examine the research model Partial Least Square (PLS) analysis technique was employed by using the SmartPLS3.0 software Ringle, Wende, and Becker (2015). In an effort to refine all structural equation model two-stage analytical procedure was employed, where researcher tested the measurement model and structural model recommended by R. Samar (2018c). Prior to structural modelling study has to assess the measurement model of latent construct for their dimensionality, validity, and reliability by going through the process named as confirmatory factor analysis (R. Samar et al., 2017). Cronbach's (α) and Composite Reliability is also tested as recommended by Henseler, Ringle, and Sinkovics (2009). Furthermore in order to check the validity of the constructs convergent and discriminant validity was also examined. Convergent validity of measurement model is usually ascertained by examining the factor loading, average variance extracted and composite reliability (J. F. Hair, Black, Babin, Anderson, & Tatham, 2010; Rahi, 2017). Figure 2 shows the results of factor loadings as recommended by Chin (1998) threshold level of 0.6. All the values were above than 0.6 that shows the convergent validity of the model.

Figure following on the next page

Figure 2: Measurement Model

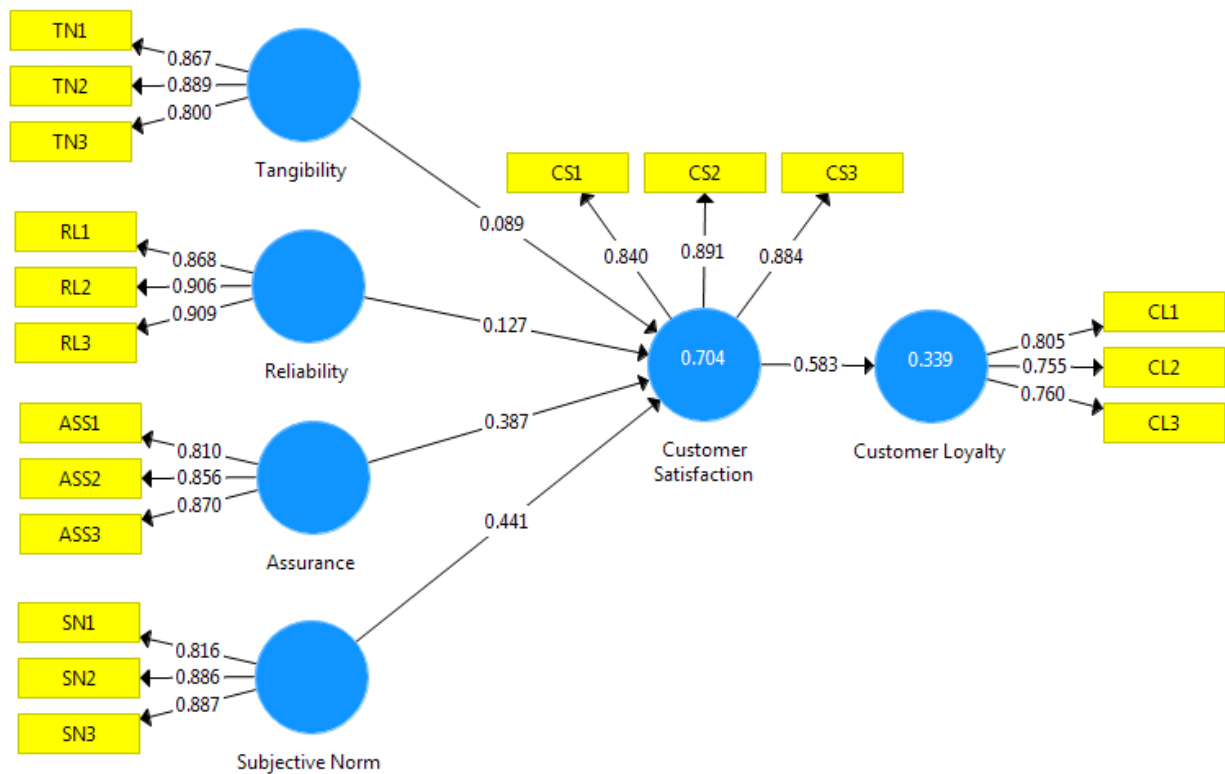

3.4.1. Convergent Validity

According to Fornell and Larcker (1981) convergent validity is measured through estimation of average variance extracted (AVE) and it must be greater than 0.5. The average variance extracted depicts the amount of variance in the indicators accounted for latent construct. Furthermore, Table 2 depicted composite reliability (CR) degree where the construct indicator represent the latent construct, values exceeded 0.7 recommended by J. F. Hair et al. (2010).

Table following on the next page

Table 2: Results of Measurement Model

Constructs	Loading	(α)	CR	AVE
Assurance	ASS	0.802	0.883	0.716
Islamic Banks offer financially safe investment	0.81			
Employees of Islamic Banks are courteous	0.856			
Employees of Islamic Banks have appropriate knowledge	0.87			
Reliability	RL	0.875	0.923	0.80
Employees of Islamic Banks fulfil their promises	0.868			
Service specifications are followed by Islamic Banks	0.906			
Islamic Banks deliver error-free services	0.909			
Subjective Norms	SN	0.828	0.898	0.745
Most people whose opinion I value would approve of my engagement in Islamic Banking	0.816			
Most people who are important to me think that I should engage in Islamic Banking	0.886			
It is expected of me that I should engage in Islamic Banking	0.887			
Customer Satisfaction	CS	0.842	0.905	0.76
Assuming your entire experience with the Islamic Banks, you are satisfied	0.84			
In general, your satisfaction level related to current Islamic Bank that you are dealing with is high	0.891			
The Islamic Banks exceed your expectations in offering quality services	0.884			
Tangibility	TN	0.812	0.889	0.728
The tools and equipment used by Islamic Banks are modern	0.867			
The facilities offered by Islamic Banks are attractive	0.889			
The communication material of Islamic Banks is easy to understand	0.800			
Customer Loyalty	CL	0.70	0.817	0.599
I would like to revisit my Islamic Bank that I have already dealt with	0.805			
I recommend my family, friends and relatives to visit the Islamic Bank that I am already dealing with	0.755			
I will spread positive word-of-mouth about my Islamic Bank and its high quality of services	0.76			

3.4.2. Discriminant Validity

Discriminant validity is the degree where items differentiate among constructs and measures distinct concepts Fornell and Larcker (1981). The discriminant validity of the instruments was examined by following Fornell and Larcker (1981). Table 3 showed that the square root of the AVE as showed in bold values on the diagonals were greater than the corresponding row and column values that indicates the measures were discriminant in this study.

Table 3: Discriminant validity of Measurement Model

Constructs	ASS	CL	CS	RL	SN	TN
Assurance	0.846					
Customer Loyalty	0.52	0.774				
Customer Satisfaction	0.715	0.583	0.872			
Reliability	0.437	0.329	0.514	0.894		
Subjective Norm	0.527	0.418	0.731	0.442	0.863	
Tangibility	0.445	0.68	0.444	0.26	0.338	0.853

Note: Bold values indicate the square root of AVE of each construct

3.4.3 Cross Loading

Discriminant validity can be measured by examining the cross loading of the indicators Hair Jr, Hult, Ringle, and Sarstedt (2016). It can be done by comparing an indicator's outer loadings on the associated constructs and it should be greater than all of its loading on the other constructs R. Samar et al. (2017). Table 4 depicts that all the items measuring a particular constructs loaded higher on that construct and loaded lower on the other constructs that confirms the discriminant validity of the constructs.

Table 4: Loading and Cross Loadings

Items	Assurance	Customer Loyalty	Customer Satisfaction	Reliability	Subjective Norm	Tangibility
ASS1	0.81	0.372	0.54	0.315	0.401	0.318
ASS2	0.856	0.453	0.604	0.394	0.474	0.405
ASS3	0.87	0.486	0.662	0.393	0.458	0.399
CL1	0.467	0.805	0.592	0.262	0.435	0.383
CL2	0.355	0.755	0.333	0.26	0.23	0.677
CL3	0.347	0.76	0.33	0.244	0.229	0.648
CS1	0.713	0.513	0.84	0.424	0.598	0.439
CS2	0.584	0.511	0.891	0.449	0.639	0.379
CS3	0.567	0.498	0.884	0.472	0.676	0.34
RL1	0.447	0.275	0.447	0.868	0.379	0.246
RL2	0.357	0.287	0.458	0.906	0.4	0.238
RL3	0.37	0.319	0.474	0.909	0.406	0.215
SN1	0.527	0.371	0.61	0.362	0.816	0.334
SN2	0.411	0.345	0.634	0.373	0.886	0.27
SN3	0.429	0.368	0.649	0.408	0.887	0.274
TN1	0.395	0.625	0.394	0.262	0.314	0.867
TN2	0.37	0.604	0.379	0.209	0.309	0.889
TN3	0.372	0.507	0.361	0.191	0.239	0.800

3.5. Structural Equation Model

After achieving measurement model the hypothesis were tested by running a bootstrapping procedure with a resample of 1000, as suggested by F. Hair Jr, Sarstedt, Hopkins, and G. Kuppelwieser (2014). Table 5 shows the hypothesis results, it can be seen that all five hypotheses have significance relationship with their respective dependant variables. The relationship between tangibility to customer satisfaction is supported by H1: ($\beta = 0.89$, $t =$

3.154, $p < 0.001$). Next to this the relationship between reliability to customer satisfaction is significant by H2: ($\beta = 0.127$, $t = 3.635$, $p < 0.001$). The relationship of H3 showed that assurance is positively related to customer satisfaction by ($\beta = 0.387$, $t = 7.525$, $p < 0.001$). Similarly, the relationship between subjective norms to customer satisfaction is supported by H4: ($\beta = 0.441$, $t = 8.357$, $p < 0.01$). Finally, the results of H5 where customer satisfaction is supported by customer loyalty by ($\beta = 0.583$, $t = 18.968$, $p < 0.001$). Thus, all hypotheses are significant. Furthermore, the effect size was also measured with R^2 . The R^2 for customer satisfaction was 0.704 and for customer loyalty 0.339, which is acceptable based on the cut-off suggested by (Cohen, 1988).

Table 5: Results of Structural Model Analysis (Hypothesis Testing)

Hypothesis	Relationship	B	S.E	t-value	P-value	Result
H1	TN -> CS	0.089	0.028	3.154	***	Significant
H2	RL -> CS	0.127	0.035	3.635	***	Significant
H3	AS-> CS	0.387	0.051	7.525	***	Significant
H4	SN-> CS	0.441	0.053	8.357	***	Significant
H5	CS-> CL	0.583	0.031	18.968	***	Significant

Note: Significance level where, * $p < 0.05$, ** $p < 0.01$, *** $p < 0.001$.

4. DISCUSSION

The service quality dimension proposed in this study found significant with respective endogenous variable. The result of reliability, tangibility and assurance is related to previous study conducted by (Rahi & Ghani, 2018a; R. Samar, 2018d; Yalley & Agyapong, 2017). Supporting with previous argument that the service quality dimensions named reliability, assurance and tangibility are considered as universal service quality dimension (Yalley & Agyapong, 2017). This study found that reliability, tangibility and assurance have significant relationship with customer satisfaction. As the purpose of this study was to integrate the SERVQUAL model with subjective norms, and findings revealed that subjective norm has significant relationship with customer satisfaction. In previous studies subjective norm has found influential factor in home financing for customer intention (Fauziah et al., 2008; Samar Rahi, Mazuri Abd Ghani, & Abdul Hafaz Ngah, 2018; R. Samar, 2018a). The Palestine region is different to west thus, it is confirmed that subjective norm played important role in measuring of service quality in Islamic banks of Palestine. Lastly, the relationship between customer satisfaction and customer loyalty have found significant and results also supported by (Kitapci, Taylan Dortyol, Yaman, & Gulmez, 2013; Raajpoot, 2004; Rahi, 2015).

5. CONCLUSION

Several studies have been conducted to investigate the service quality issues in banking sector in different context. Therefore, current research has two major contributions. First, this study tested the universal SERVQUAL dimension named assurance, tangibility and reliability in Islamic banks of Palestine. Second, this study also extended the SERVQUAL dimension with subjective norm in ARAB region such as Palestine. The newly proposed model collectively impact on customer satisfaction with 70% variance and 33% variance on customer satisfaction to customer loyalty. Thus, this study confirmed a new model that reflects on Arab culture with addition of Palestine people subjective norms.

LITERATURE:

1. Alnaser, F. M. I., Ghani, M. A., Rahi, S., Mansour, M., & Abed, H. (2017). The Influence of Services Marketing Mix (7 Ps.) and Subjective Norms on Customer's Satisfaction in Islamic Banks of Palestine. *European Journal of Business and Management*, 9(27).

2. Alnaser, F., Ghani, M., & Rahi, S. (2017). The Impact of SERVQUAL Model and Subjective Norms on Customer's Satisfaction and Customer Loyalty in Islamic Banks: A Cultural Context. *Int J Econ Manag Sci*, 6(5), 455.
3. Alnaser, F., Ghani, M., & Rahi, S. (2018). Service quality in Islamic banks: The role of PAKSERV model, customer satisfaction and customer loyalty. *Accounting*, 4(2), 63-72.
4. Alnaser, F., Ghani, M., Rahi, S., Mansour, M., & Abed, H. (2017). Determinants of Customer Loyalty: The Role of Service Quality, Customer Satisfaction and Bank Image of Islamic Banks in Palestine. *Int J Econ Manag Sci*, 6(461), 2.
5. Amin, M., Isa, Z., & Fontaine, R. (2013). Islamic banks: Contrasting the drivers of customer satisfaction on image, trust, and loyalty of Muslim and non-Muslim customers in Malaysia. *International Journal of Bank Marketing*, 31(2), 79-97.
6. Baumann, C., Elliott, G., & Hamin, H. (2011). Modelling customer loyalty in financial services: a hybrid of formative and reflective constructs. *International Journal of Bank Marketing*, 29(3), 247-267.
7. Cai, C. M., Zhang, T., Kumar, R., & Wyman, C. E. (2014). Integrated furfural production as a renewable fuel and chemical platform from lignocellulosic biomass. *Journal of Chemical Technology and Biotechnology*, 89(1), 2-10.
8. Chin, W. W. (1998). Commentary: Issues and opinion on structural equation modeling: JSTOR.
9. Chumpitaz, R., & Paparoidamis, N. G. (2004). Service quality and marketing performance in business-to-business markets: exploring the mediating role of client satisfaction. *Managing Service Quality: An International Journal*, 14(2/3), 235-248.
10. Cohen, J. (1988). *Statistical power analysis for the behavioural sciences*. Hillside. NJ: Lawrence Earlbaum Associates.
11. F. Hair Jr, J., Sarstedt, M., Hopkins, L., & G. Kuppelwieser, V. (2014). Partial least squares structural equation modeling (PLS-SEM) An emerging tool in business research. *European Business Review*, 26(2), 106-121.
12. Fishbein, M., & Ajzen, I. (1975). *Belief, Attitude, Intention and Behavior: An Introduction to Theory and Research Reading, MA: Addison-Wesley*, 6.
13. Fornell, C., & Larcker, D. F. (1981). Structural equation models with unobservable variables and measurement error: Algebra and statistics. *Journal of Marketing Research*, 382-388.
14. Grönroos, C. (1984). A service quality model and its marketing implications. *European Journal of marketing*, 18(4), 36-44.
15. Hair Jr, J. F., Hult, G. T. M., Ringle, C., & Sarstedt, M. (2016). *A primer on partial least squares structural equation modeling (PLS-SEM)*: Sage Publications.
16. Hair, J. F. (2003). *Essentials of Business Research Methods*: Wiley.
17. Hair, J. F., Black, W. C., Babin, B. J., Anderson, R. E., & Tatham, R. L. (2010). *Multivariate Data Analysis 7*.
18. Henseler, J., Ringle, C. M., & Sinkovics, R. R. (2009). The use of partial least squares path modeling in international marketing. *Advances in international marketing*, 20(1), 277-319.
19. Hyllegard, K. H., Paff Ogle, J., Yan, R.-N., & Attmann, J. (2010). Exploring Gen Y Responses to an Apparel Brand's Use of Cause-Related Marketing Does Message Matter When It Comes to Support for the Breast Cancer Cause? *Clothing and Textiles Research Journal*, 28(1), 19-34.
20. Kitapci, O., Taylan Dortyol, I., Yaman, Z., & Gulmez, M. (2013). The paths from service quality dimensions to customer loyalty: An application on supermarket customers. *Management Research Review*, 36(3), 239-255.

21. Kyoon Yoo, D., & Ah Park, J. (2007). Perceived service quality: Analyzing relationships among employees, customers, and financial performance. *International Journal of Quality & reliability management*, 24(9), 908-926.
22. Ladhari, R., Ladhari, I., & Morales, M. (2011). Bank service quality: comparing Canadian and Tunisian customer perceptions. *International Journal of Bank Marketing*, 29(3), 224-246.
23. Lee, J.-H., Kim, H.-D., Ko, Y. J., & Sagas, M. (2011). The influence of service quality on satisfaction and intention: A gender segmentation strategy. *Sport Management Review*, 14(1), 54-63.
24. Marković, S., Jelena, D., & Katušić, G. (2015). *Service Quality Measurement in Croatian Banking Sector: Application of SERVQUAL Model*. Paper presented at the MIC 2015: Managing Sustainable Growth.
25. Mazuri, A. G., Samar, R., Norjaya, M. Y., & Feras, M. A. (2017). Adoption of Internet Banking: Extending the Role of Technology Acceptance Model (TAM) with E-Customer Service and Customer Satisfaction. *World Applied Sciences Journal*, 35(9).
26. Oliver, R. L. (1997). *Loyalty and profit: Long-term effects of satisfaction*.
27. Oly Ndubisi, N. (2007). Relationship marketing and customer loyalty. *Marketing Intelligence & Planning*, 25(1), 98-106.
28. Pantouvakis, A. (2013). The moderating role of nationality on the satisfaction loyalty link: evidence from the tourism industry. *Total Quality Management & Business Excellence*, 24(9-10), 1174-1187.
29. Parasuraman, A., Zeithaml, V. A., & Berry, L. L. (1988). Servqual: A multiple-item scale for measuring consumer perc. *Journal of retailing*, 64(1), 12.
30. Parasuraman, Zeithaml, V. A., & Berry, L. L. (1985). A conceptual model of service quality and its implications for future research. *the Journal of Marketing*, 41-50.
31. Parkinson, J., Russell-Bennett, R., & Previte, J. (2012). Mum or bub? Which influences breastfeeding loyalty. *Australasian Marketing Journal (AMJ)*, 20(1), 16-23.
32. Raajpoot, N. (2004). Reconceptualizing service encounter quality in a non-western context. *Journal of Service Research*, 7(2), 181-201.
33. Rahi Samar, Mazuri Abd Ghani, & ALNASER, F. M.-I.-. (2017). THE INFLUENCE OF E-CUSTOMER SERVICES AND PERCEIVED VALUE ON BRAND LOYALTY OF BANKS AND INTERNET BANKING ADOPTION: A STRUCTURAL EQUATION MODEL (SEM). *Journal of Internet Banking and Commerce*, 22(1).
34. Rahi, S. (2015). Moderating Role of Brand Image With Relation to Internet Banking and Customer Loyalty: A Case of Branchless Banking. *The Journal of Internet Banking and Commerce*, 2015.
35. Rahi, S. (2016). Impact of Customer Perceived Value and Customer's Perception of Public Relation on Customer Loyalty with Moderating Role of Brand Image. *Journal of Internet Banking and Commerce*, 21(2).
36. Rahi, S. (2016). Impact of Customer Value, Public Relations Perception and Brand Image on Customer Loyalty in Services Sector of Pakistan. *Arabian J Bus Manag Review S*, 2, 2.
37. Rahi, S. (2017). Research Design and Methods: A Systematic Review of Research Paradigms, Sampling Issues and Instruments Development. *International Journal of Economics & Management Sciences*, 6(2).
38. Rahi, S., & Ghani, M. (2016). Internet Banking, Customer Perceived Value and Loyalty: The Role of Switching Costs. *J Account Mark*, 5(4), 188. doi: 10.4172/2168-9601.1000188
39. Rahi, S., & Ghani, M. A. (2016). Customer's Perception of Public Relation in E-Commerce and its Impact on E-Loyalty with Brand Image and Switching Cost. *Journal of Internet Banking and Commerce*, 21(3).

40. Rahi, S., & Ghani, M. A. (2018a). *Investigating the Role of E-Service Quality and Brand Image in Internet Banking acceptance context with Structural Equation Modeling (SEM-PLS)*. Paper presented at the Economic and Social Development (Book of Proceedings), 29th International Scientific Conference on Economic and Social.
41. Rahi, S., & Ghani, M. A. (2018b). *A STRUCTURAL EQUATION MODELING (SEM-AMOS) FOR INVESTIGATING BRAND LOYALTY AND CUSTOMER'S INTENTION TOWARDS ADOPTION OF INTERNET BANKING*. Paper presented at the Economic and Social Development (Book of Proceedings), 29th International Scientific Conference on Economic and Social.
42. Rahi, S., Ghani, M. A., & Ngah, A. H. (2018). A structural equation model for evaluating user's intention to adopt internet banking and intention to recommend technology ., *Accounting*, 4(4), 129-170. doi: 10.5267/j.ac.2018.3.002
43. Rahi, S., Ghani, M. A., & Ngah, A. H. (2018). Factors Propelling the Adoption of Internet Banking: The Role of E-Customer Service, Website Design, Brand Image and Customer Satisfaction. *International journal of Business Information System* 28.
44. Rahi, S., Ghani, M., & Muhamad, F. (2017). Inspecting the Role of Intention to Trust and Online Purchase in Developing Countries. *J Socialomics* 6(1). doi: 10.41 72/2167-0358.1000191
45. Rahi, S., Ghani, M., Alnaser, F., & Ngah, A. (2018). Investigating the role of unified theory of acceptance and use of technology (UTAUT) in internet banking adoption context. *Management Science Letters*, 8(3), 173-186.
46. Ringle, C. M., Wende, S., & Becker, J.-M. (2015). *SmartPLS 3*. Boenningstedt: SmartPLS GmbH.
47. Roca, J. C., Chiu, C.-M., & Martínez, F. J. (2006). Understanding e-learning continuance intention: An extension of the Technology Acceptance Model. *International journal of human-computer studies*, 64(8), 683-696.
48. Ryan, M. J., & Bonfield, E. H. (1975). The Fishbein extended model and consumer behavior. *Journal of consumer research*, 2(2), 118-136.
49. Samar, R. (2018a). E-Banking Challenges and Opportunities: An Empirical Investigation on Branchless Banking. *CreateSpace Independent Publishing Platform*, 1.
50. Samar, R. (2018b). Research Design and Methods. *CreateSpace Independent Publishing Platform*, 1.
51. Samar, R. (2018c). Structural Equation Modeling Using SmartPLS. *CreateSpace Independent Publishing Platform*.
52. Samar, R. (2018d). Technology Adoption Issues in Banks. *CreateSpace Independent Publishing Platform*, 1.
53. Samar, R., Norjaya, M. Y., & Feras, M. A. (2017). Measuring the role of website design, assurance, customer service and brand image towards customer loyalty and intention to adopt internet banking. *The Journal of Internet Banking and Commerce*, 22(S8).
54. Samar, S., Ghani, M., & Alnaser, F. (2017). Predicting customer's intentions to use internet banking: the role of technology acceptance model (TAM) in e-banking. *Management Science Letters*, 7(11), 513-524.
55. Sayani, H. (2015). Customer satisfaction and loyalty in the United Arab Emirates banking industry. *International Journal of Bank Marketing*, 33(3), 351-375.
56. Ueltschy, L. C., Laroche, M., Zhang, M., Cho, H., & Yingwei, R. (2009). Is there really an Asian connection? Professional service quality perceptions and customer satisfaction. *Journal of business research*, 62(10), 972-979.
57. Venkatesh, V., & Davis, F. D. (2000). A theoretical extension of the technology acceptance model: Four longitudinal field studies. *Management science*, 46(2), 186-204.

58. Yalley, A. A., & Agyapong, G. K. (2017). Measuring service quality in Ghana: a crossvergence cultural perspective. *Journal of Financial Services Marketing*, 1-11.
59. Zeithaml, V. A., Berry, L. L., & Parasuraman, A. (1996). The behavioral consequences of service quality. *the Journal of Marketing*, 31-46.



كلية العلوم القانونية والاقتصادية والاجتماعية - سلا
Fakultet prawniczy, ekonomiczny i społeczny - Słoneczna
Faculté des sciences juridiques
économiques et sociales - salé